

Wall Mounted Gowning Racks with Hanger Slots

ASSEMBLY INSTRUCTIONS

CAUTION

INSPECT CONTENTS IMMEDIATELY AND FILE CLAIM WITH DELIVERING CARRIER FOR ANY DAMAGE. **SAVE YOUR BOX AND ALL PACKING MATERIALS.** YOU ARE RESPONSIBLE FOR DAMAGE TO YOUR UNIT IF RETURNED IMPROPERLY PACKED.

Parts List

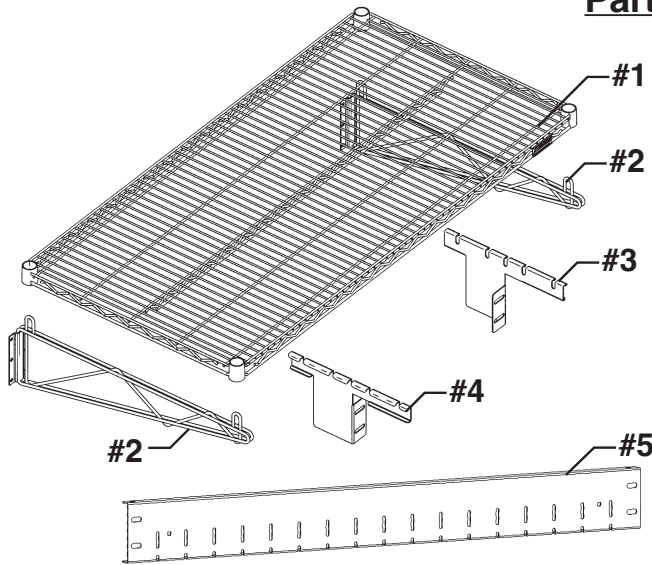

#	qty	part #	description
#1	1	*	wire shelf
#2	2	*	wall bracket
#3	1	*	right hanger bar bracket
#4	1	*	left hanger bar bracket
#5	1	*	hanger bar
#6	4	306138	3/8"-16 x 3/4" bolt
#7	4	312049	3/8" hex nut

* Size and/or finish determines part number.

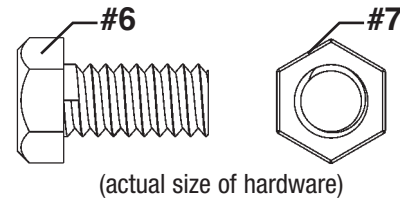

IMPORTANT NOTE:

Wall mounted units must be attached to a properly constructed and sound wall. For walls constructed of wood or steel studs, the mounting points must be directly on the stud or suitable in-wall-grounds of plywood or sheet metal. Eagle Group cannot be held responsible for the failure of the device or any other devices due to improper installation.

Step 1

- To determine location of wall brackets*, measure the distance between the outer holes of each wall bracket mounting plate by adding 3/8" to shelf length (example: For 60"-long shelf, total distance between the outer holes of each mounting plate is 60-3/8").
- Use a level to ensure the left and right set of holes are level with one another. Mark holes.
- Drill holes and affix each bracket to wall. Wall-mounting hardware not included.

* **Hint:** Place the shelf over the bracket before marking the mounting plate locations. This will help with proper location of bracket, and aid in the overall mounting process. Check the shelf with a level, prior to mounting. If the wall is not plumb, spacer washers should be added. Spacer washers not included.

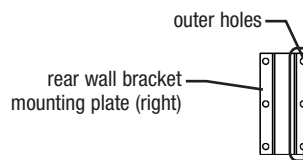
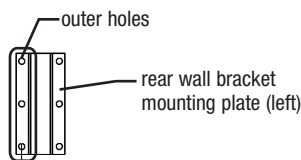

ADD 3/8" TO SHELF LENGTH

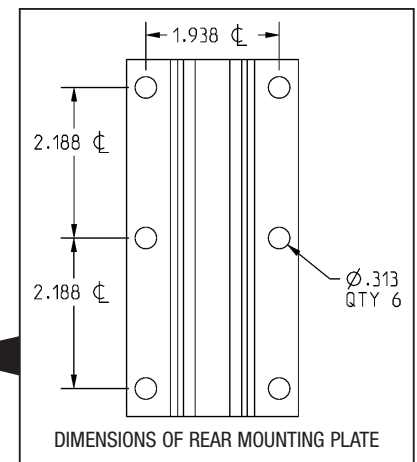

(continued on next page)

Wall Mounted Gowning Racks with Hanger Slots

ASSEMBLY INSTRUCTIONS

Step 2

Lay the wire shelf atop the wall brackets, as shown.

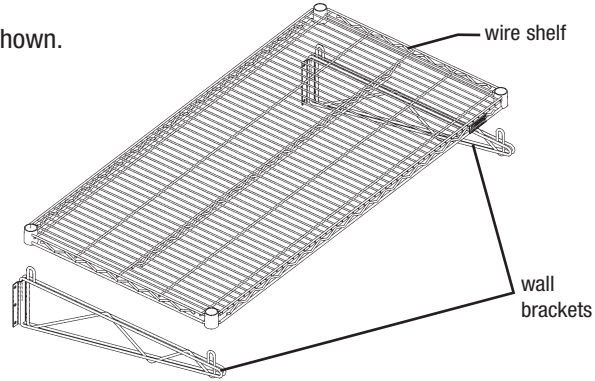
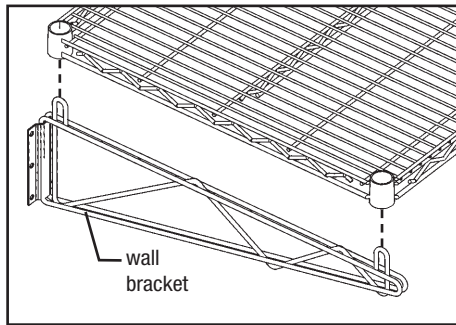

Step 3

Hook the hanger bar brackets onto underside of wire shelf, as shown.

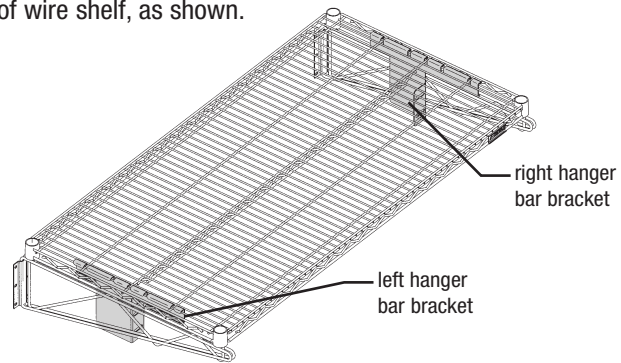
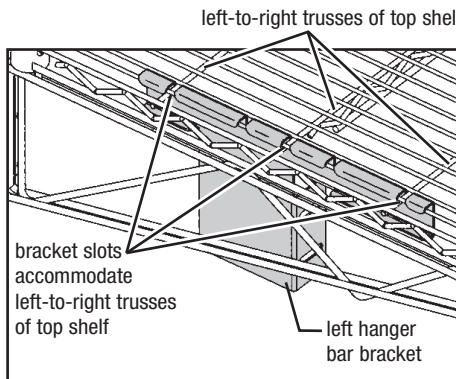

Step 4

Using hardware provided, attach hanger bar to hanger bar brackets, as shown.

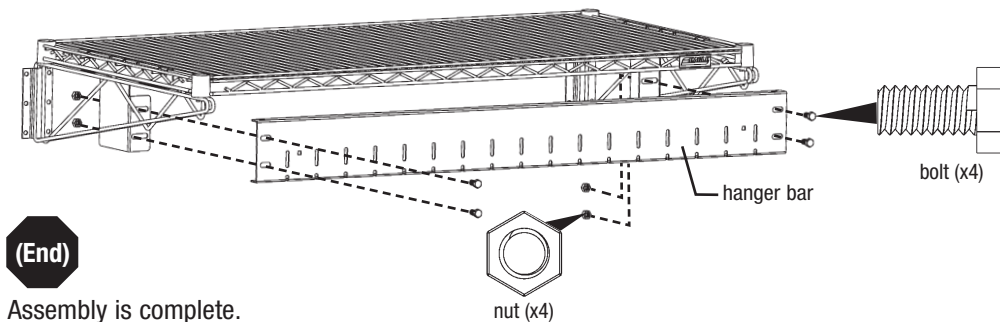

Assembly is complete.



WARNING – IMPORTANT NOTES



- Heavier objects should be stored at lower levels.
- Always be sure shelves are properly leveled.
- Do not step, stand, climb, or hang on shelving.
- Do not drop heavy objects onto shelves.
- Never overload shelving.

Failure to follow these guidelines can result in property damage or personal injury.



- 100 Industrial Boulevard, Clayton, Delaware 19938-8903 U.S.A.
- Phone: 302/653-3000 • 800/441-8440 • Fax: 302/653-2065
- www.eaglegrp.com • www.eaglehmc.com