

Electronic Tray Carts

ASSEMBLY INSTRUCTIONS

CAUTION

INSPECT CONTENTS IMMEDIATELY AND FILE CLAIM WITH DELIVERING CARRIER FOR ANY DAMAGE. **SAVE YOUR BOX AND ALL PACKING MATERIALS.** YOU ARE RESPONSIBLE FOR DAMAGE TO YOUR UNIT IF RETURNED IMPROPERLY PACKED.

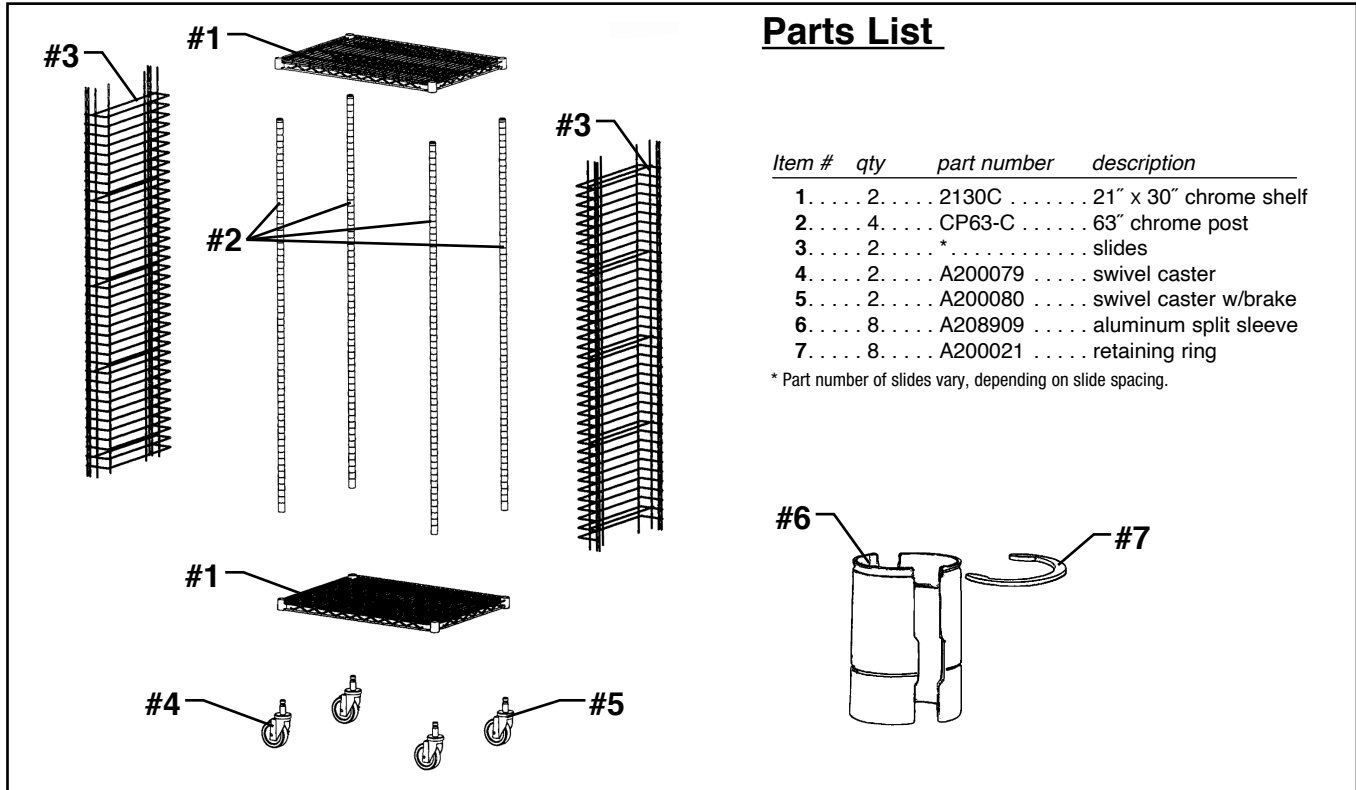

Parts List

Item #	qty	part number	description
1	2	2130C	21" x 30" chrome shelf
2	4	CP63-C	63" chrome post
3	2	*	slides
4	2	A200079	swivel caster
5	2	A200080	swivel caster w/brake
6	8	A208909	aluminum split sleeve
7	8	A200021	retaining ring

* Part number of slides vary, depending on slide spacing.

Step 1 - Attach caster to bottom of each post.

Note: the bottom is the end without a black cap.

Step 2 - Attach split sleeve to the lowest groove of each post.

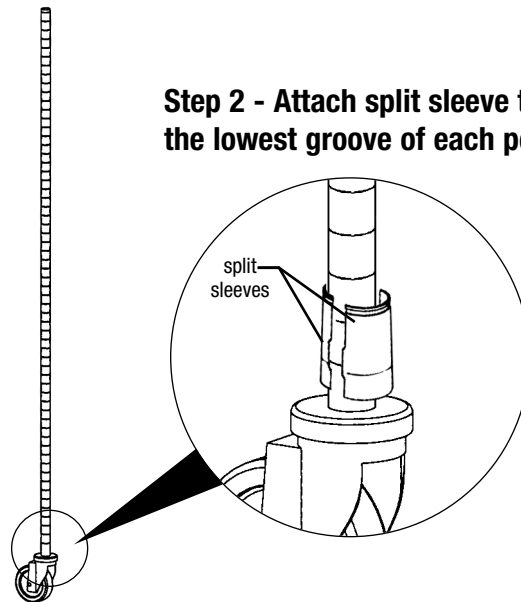

(continued on back page)

EG9984 Revised 10/23

Electronic Tray Carts

ASSEMBLY INSTRUCTIONS

Step 3 - Attach bottom shelf to posts.

With a rubber mallet or a piece of wood and a hammer, gently tap shelf until top of split sleeve groove is showing.

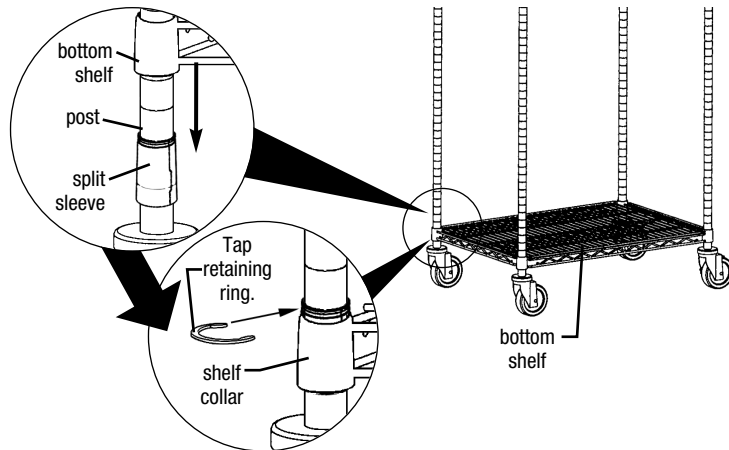

Step 4 - Attach slides.

(Note: the bottom of the slide is the end with shorter wires protruding.)

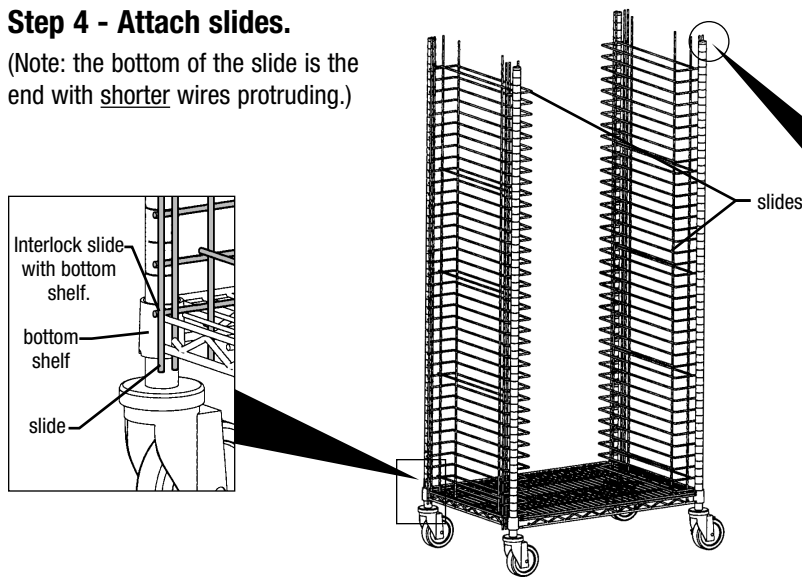

Step 5 - Attach split sleeve to top groove of each post.

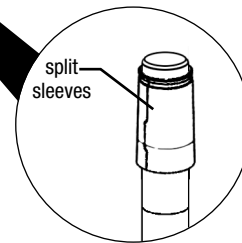

Step 6 - Attach top shelf.

Refer to Step 3.

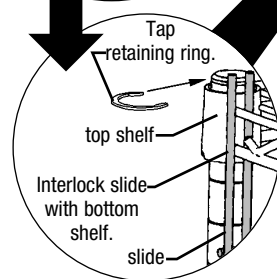
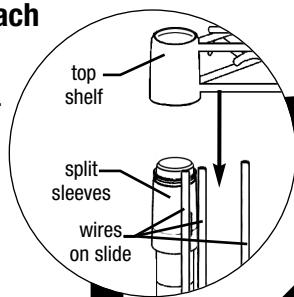

Step 7 - Cover top wires with round vinyl caps.

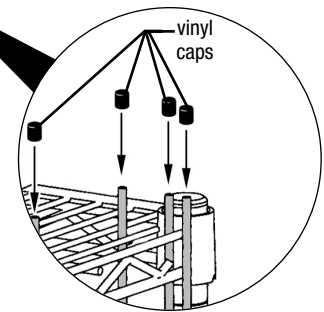

(End)

Assembly is complete.

EAGLE GROUP
Profit from the Eagle Advantage®

- 100 Industrial Boulevard, Clayton, Delaware 19938-8903 U.S.A.
- Phone: 302/653-3000 • 800/441-8440 • Fax: 302/653-2065
- www.eaglegrp.com • www.eaglegrpnews.com • www.eaglemhc.com