

Wall Shelves

ASSEMBLY INSTRUCTIONS

For Wall Shelves with Pot Rack, see reverse side.

CAUTION

INSPECT CONTENTS IMMEDIATELY AND FILE CLAIM WITH DELIVERING CARRIER FOR ANY DAMAGE. **SAVE YOUR BOX AND ALL PACKING MATERIALS.** YOU ARE RESPONSIBLE FOR DAMAGE TO YOUR UNIT IF RETURNED IMPROPERLY PACKED.

Centerline Locations

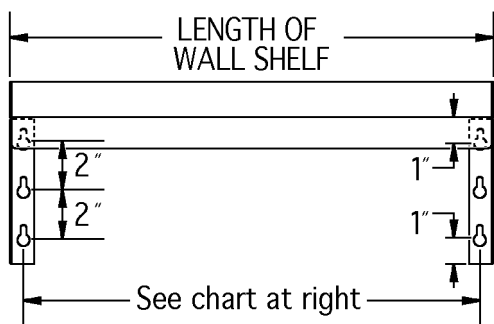

# of brackets	length of wall shelf	1st centerline	2nd centerline	3rd centerline	4th centerline	5th centerline
2	24"	22 ¹⁵ / ₁₆ "	n/a	n/a	n/a	n/a
	36"	34 ¹⁵ / ₁₆ "	n/a	n/a	n/a	n/a
3	48"	23 ⁷ / ₁₆ "	23 ⁷ / ₁₆ "	n/a	n/a	n/a
	60"	29 ⁷ / ₁₆ "	29 ⁷ / ₁₆ "	n/a	n/a	n/a
4	72"	23 ³ / ₁₆ "	23 ³ / ₁₆ "	23 ³ / ₁₆ "	n/a	n/a
	84"	27 ⁵ / ₁₆ "	27 ⁵ / ₁₆ "	27 ⁵ / ₁₆ "	n/a	n/a
5	96"	23 ³ / ₁₆ "	23 ³ / ₁₆ "	23 ³ / ₁₆ "	23 ³ / ₁₆ "	n/a
	102"	25 ¹ / ₄ "	25 ¹ / ₄ "	25 ¹ / ₄ "	25 ¹ / ₄ "	n/a
6	108"	21 ³ / ₈ "	21 ³ / ₈ "	21 ³ / ₈ "	21 ³ / ₈ "	21 ³ / ₈ "
	120"	23 ¹³ / ₁₆ "	23 ¹³ / ₁₆ "	23 ¹³ / ₁₆ "	23 ¹³ / ₁₆ "	23 ¹³ / ₁₆ "
	132"	26 ³ / ₁₆ "	26 ³ / ₁₆ "	26 ³ / ₁₆ "	26 ³ / ₁₆ "	26 ³ / ₁₆ "
	144"	28 ⁹ / ₁₆ "	28 ⁹ / ₁₆ "	28 ⁹ / ₁₆ "	28 ⁹ / ₁₆ "	28 ⁹ / ₁₆ "

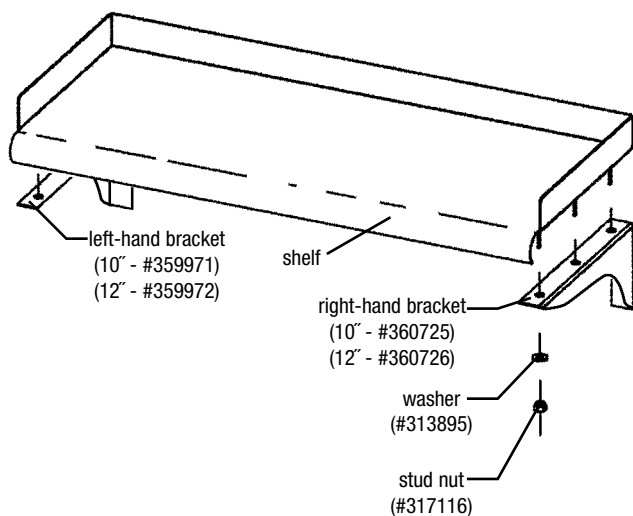

Step 1

Remove the stud nuts found on the bottom of the shelf.

Step 2

Lay shelf on brackets and replace the stud nut.

Step 3

Mount to wall, using "Centerline Locations" chart above.



Wall Shelves with Pot Rack

ASSEMBLY INSTRUCTIONS

CAUTION

INSPECT CONTENTS IMMEDIATELY AND FILE CLAIM WITH DELIVERING CARRIER FOR ANY DAMAGE. **SAVE YOUR BOX AND ALL PACKING MATERIALS.** YOU ARE RESPONSIBLE FOR DAMAGE TO YOUR UNIT IF RETURNED IMPROPERLY PACKED.

Centerline Locations

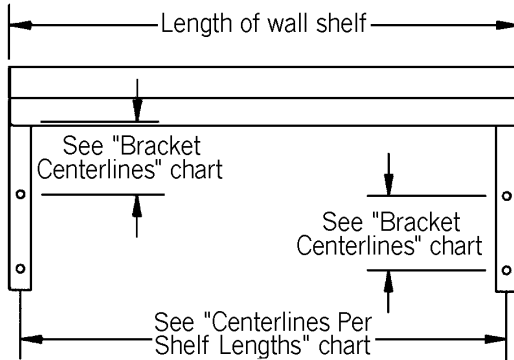

<i>Centerlines Per Shelf Lengths</i>						
<i># of brackets</i>	<i>length of wall shelf</i>	<i>1st centerline</i>	<i>2nd centerline</i>	<i>3rd centerline</i>	<i>4th centerline</i>	<i>5th centerline</i>
2	36"	34 ¹ / ₁₆ "	n/a	n/a	n/a	n/a
3	48"	46 ¹ / ₁₆ "	n/a	n/a	n/a	n/a
4	60"	29 ⁷ / ₁₆ "	29 ⁷ / ₁₆ "	n/a	n/a	n/a
	72"	23 ³ / ₁₆ "	23 ³ / ₁₆ "	23 ³ / ₁₆ "	n/a	n/a
5	84"	27 ⁵ / ₁₆ "	27 ⁵ / ₁₆ "	27 ⁵ / ₁₆ "	n/a	n/a
	96"	23 ³ / ₁₆ "	23 ³ / ₁₆ "	23 ³ / ₁₆ "	23 ³ / ₁₆ "	n/a
6	102"	25 ¹ / ₄ "	25 ¹ / ₄ "	25 ¹ / ₄ "	25 ¹ / ₄ "	n/a
	108"	21 ³ / ₈ "	21 ³ / ₈ "	21 ³ / ₈ "	21 ³ / ₈ "	21 ³ / ₈ "
6	120"	23 ¹ / ₁₆ "	23 ¹ / ₁₆ "	23 ¹ / ₁₆ "	23 ¹ / ₁₆ "	23 ¹ / ₁₆ "
	132"	26 ³ / ₁₆ "	26 ³ / ₁₆ "	26 ³ / ₁₆ "	26 ³ / ₁₆ "	26 ³ / ₁₆ "
	144"	28 ³ / ₁₆ "	28 ³ / ₁₆ "	28 ³ / ₁₆ "	28 ³ / ₁₆ "	28 ³ / ₁₆ "

Bracket Centerlines

<i>width of wall shelf</i>	<i>centerline</i>
10"	3 ¹ / ₂ "
12"	4 ¹ / ₂ "

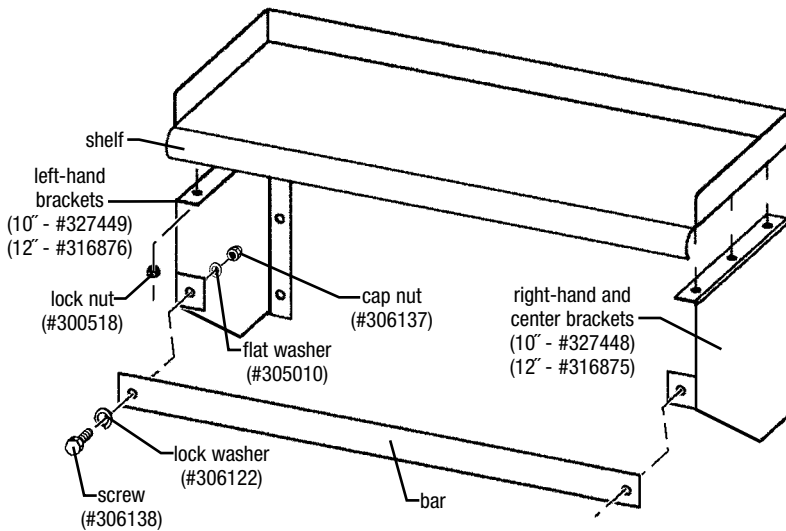

Step 1

Remove the lock nuts found on the bottom of the shelf.

Step 2

Lay shelf on brackets and replace the lock nuts.

Step 3

Attach front bar as shown.

Step 4

Mount to wall, using "Centerline Locations" charts above.



lock nut
#300518

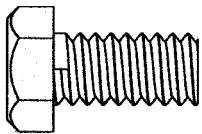

screw
#306138



lock washer
#306122

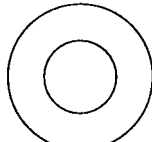

flat washer
#305010

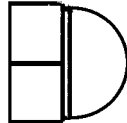

cap nut
#306137

(actual size of hardware)



Profit from the Eagle Advantage®

Eagle Foodservice Equipment, Eagle MHC, and SpecFAB® are divisions of Eagle Group. ©2023 by the Eagle Group

- 100 Industrial Boulevard, Clayton, Delaware 19938-8903 U.S.A.
- Phone: 302/653-3000 • 800/441-8440 • Fax: 302/653-2065
- www.eaglegrp.com • www.eaglegrpnews.com • www.eaglemhc.com