



Profit from the Eagle Advantage®

Phone: (800) 441-8440 • (302) 653-3000

FAX: (302) 653-2065

Product

Announcement

Short Form Specifications

Eagle Worktable with Knockdown Welded Base Option, _____ . Undershelf is welded and constructed of heavy gauge stainless steel with marine edge. Top and upper leg assembly are removable from the welded base. Top reinforced with hat channels and sound deadened. Constructed with uni-lok® gusset system with the gussets recessed into the hat channels to reduce lateral movement. Legs are 1 5/8" O.D., stainless steel, with galvanized gussets and 1" stainless steel adjustable bullet feet.

Item #: _____
 Model #: _____
 Project #: _____
 SIS #: _____

EG8217 Rev. 07/23

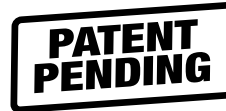

Knockdown Welded Base Option

— For Worktables with Stainless Steel Base



table with undershelf knocked down

Easily assembles in minutes!



table assembled



table with tubular base knocked down



table assembled

Easily assembles in minutes!

How Our Tables with Knockdown Welded Base Rate...

	Types of Construction:		
	Knockdown	Knockdown Welded Base	Welded Base
Strength	☆☆☆☆☆	☆☆☆☆☆	☆☆☆☆☆
Stability	☆☆☆☆☆	☆☆☆☆☆	☆☆☆☆☆
Durability	☆☆☆☆☆	☆☆☆☆☆	☆☆☆☆☆
Shipping Costs	☆☆☆☆☆	☆☆☆☆☆	☆☆☆☆☆
Packaging Waste	☆☆☆☆☆	☆☆☆☆☆	☆☆☆☆☆
Price	☆☆☆☆☆	☆☆☆☆☆	☆☆☆☆☆

Knockdown welded base construction provides the best of both worlds: A rigid welded base for additional stability and durability, while knockdown construction reduces shipping volume and packaging waste.



Eagle Knockdown Welded Base Option

— Available For Eagle Worktables with Stainless Steel Base

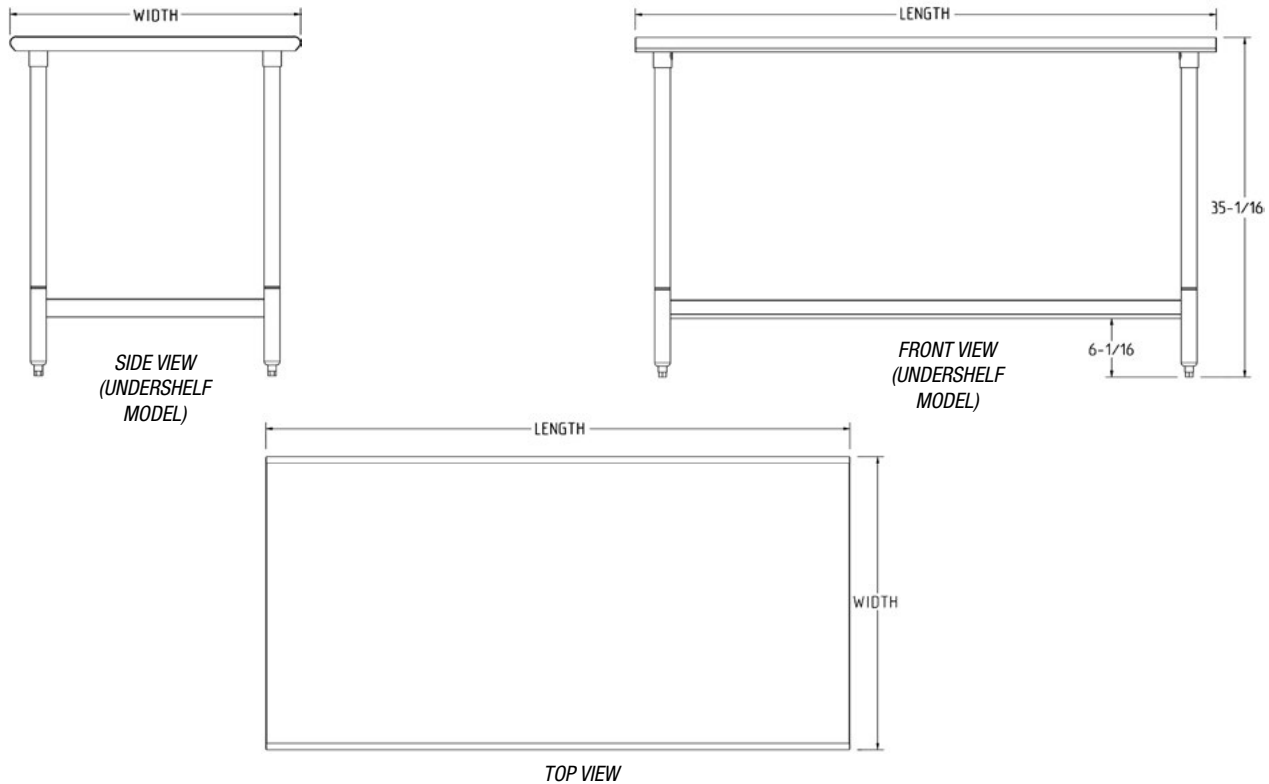

Design and Construction Features

Knockdown Welded Base Option

Base Options:

- Marine edge stainless steel undershef welded to lower leg sections
- C-Frame stainless steel tubular base

Legs:

- 16 gauge 1 5/8" diameter legs
- Precision machined stainless steel threaded inserts pressed into leg sections for knockdown construction

For custom configuration or fabrication needs, contact our **SpecFAB® Division**.

Phone: (302) 653-3000. FAX: (302) 653-2065.

E-mail: quotes@eaglegrp.com

Add suffix: - **KDWB**
to worktable model number

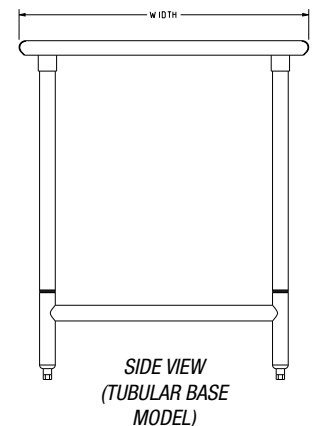
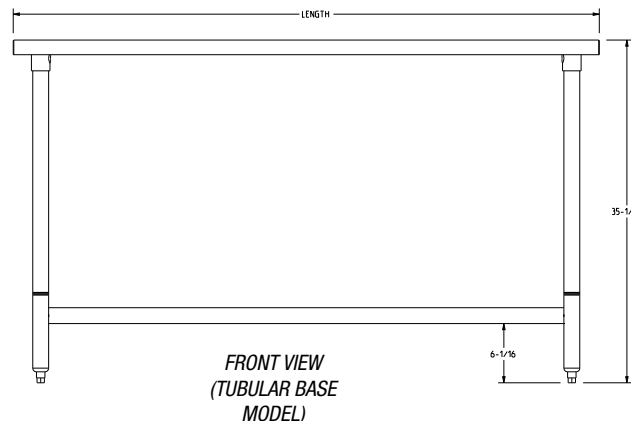

Printed in U.S.A.
©2023 by Eagle Group

EG8217 Rev. 07/23