

# Cleanroom Tables with H-Frame

## ASSEMBLY INSTRUCTIONS

### CAUTION

INSPECT CONTENTS IMMEDIATELY AND FILE CLAIM WITH DELIVERING CARRIER FOR ANY DAMAGE. **SAVE YOUR BOX AND ALL PACKING MATERIALS.** YOU ARE RESPONSIBLE FOR DAMAGE TO YOUR UNIT IF RETURNED IMPROPERLY PACKED.

For Cleanroom Table with C-Frame, see page 2.

For Cleanroom Table with Undershelf, see page 3.

For Casters, see back page.

### Step 1 - Assemble tubular frame.

- Attach knockdown tube to front-to-back crossbracings.
- Tighten bolt at each end.

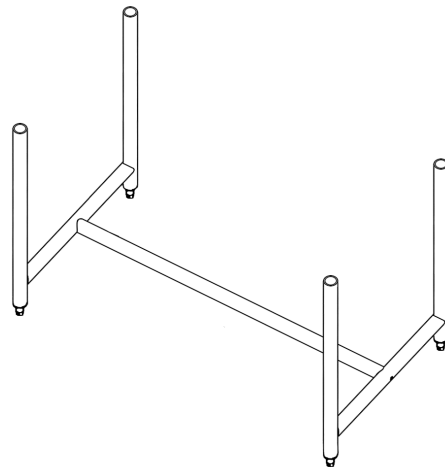
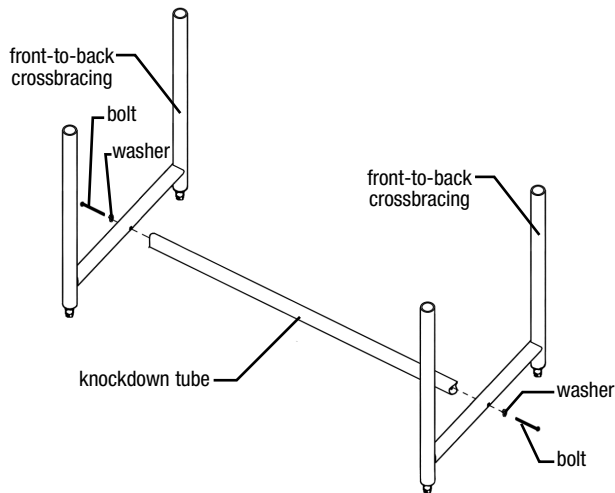

Frame fully assembled.

### Step 2 - Attach tabletop.

- Turn tabletop upside-down (take care not to scratch the finish).
- Turn tubular frame upside-down and insert top of each leg into each tabletop gusset.
- At each gusset, tighten set screw.

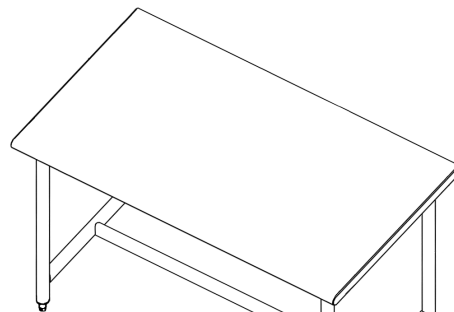
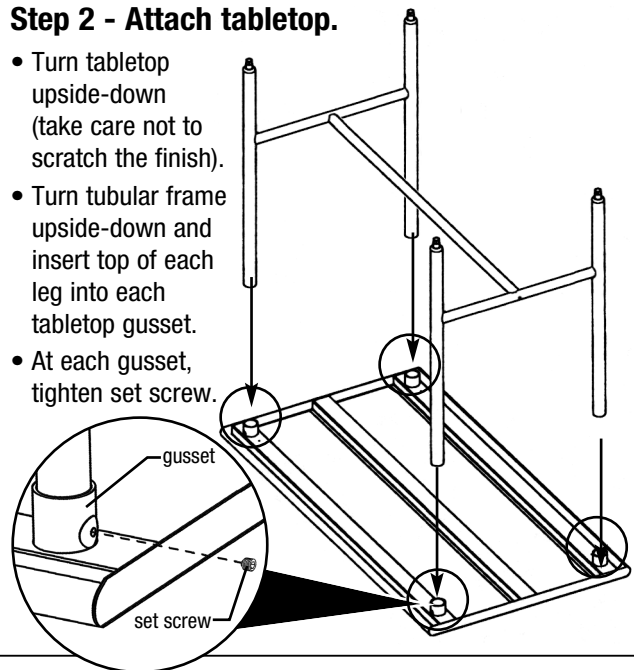

Level table with adjustable feet.

**(End)** Assembly is complete.

# Cleanroom Tables with C-Frame

## ASSEMBLY INSTRUCTIONS

For Cleanroom Table with H-Frame, see front page.

For Cleanroom Table with Undersheff, see page 3.

For Casters, see back page.

### Step 1 - Assemble tubular frame.

- Attach knockdown tube to front-to-back crossbracings.
- Tighten bolt at each end.

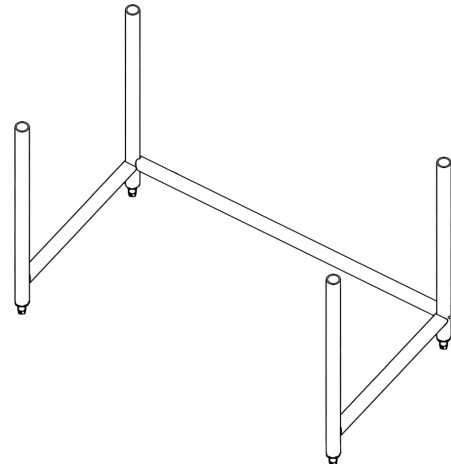
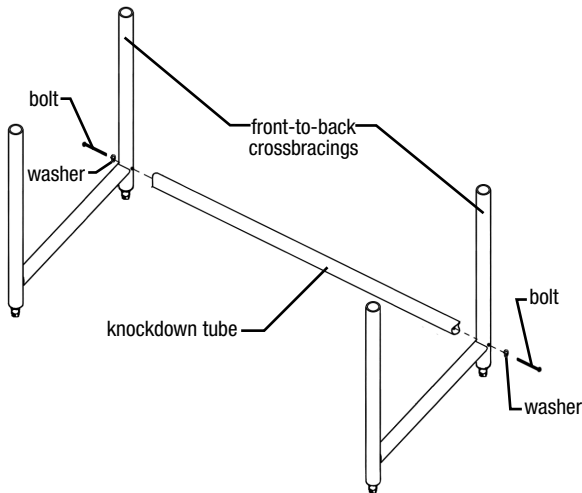

Frame fully assembled.

### Step 2 - Attach tabletop.

- Turn tabletop upside-down (take care not to scratch the finish).
- Turn tubular frame upside-down and insert top of each leg into each tabletop gusset.
- At each gusset, tighten set screw.

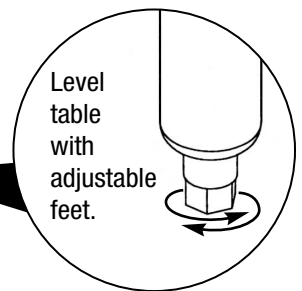
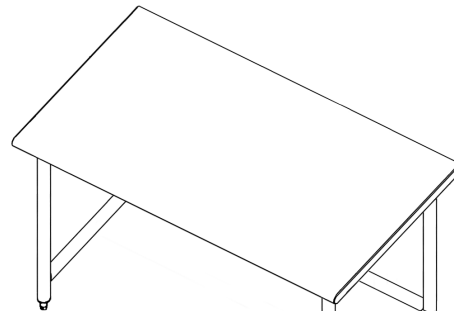
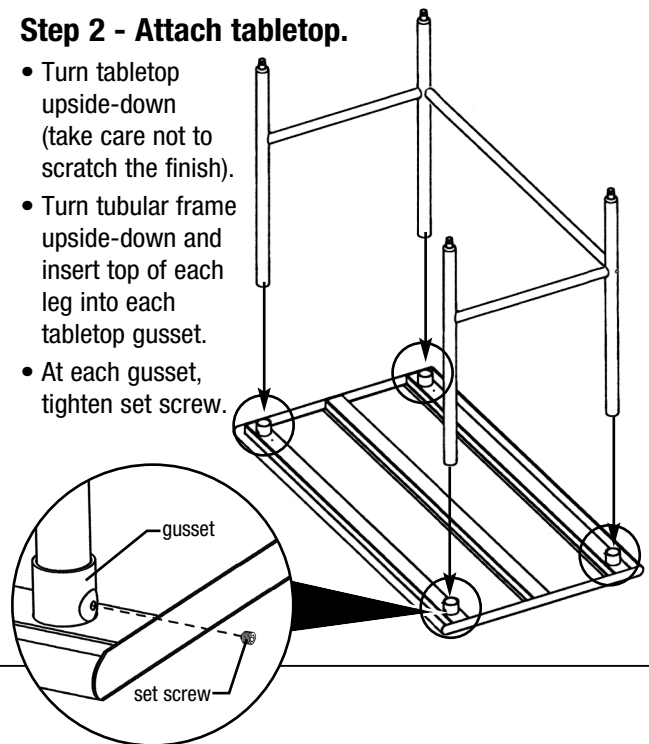

**(End)** Assembly is complete.

# Cleanroom Tables with Undershef

## ASSEMBLY INSTRUCTIONS

For Cleanroom Table with H-Frame, see front page.

For Cleanroom Table with C-Frame, see page 2.

For Casters, see back page.

### Step 1 - Bolt undershef to one leg.

- Lay the assembly onto its side.
- Bolt the undershef to one of the legs with bolt provided.
- Use nut provided to tighten and secure the bolt to both the leg and the undershef.

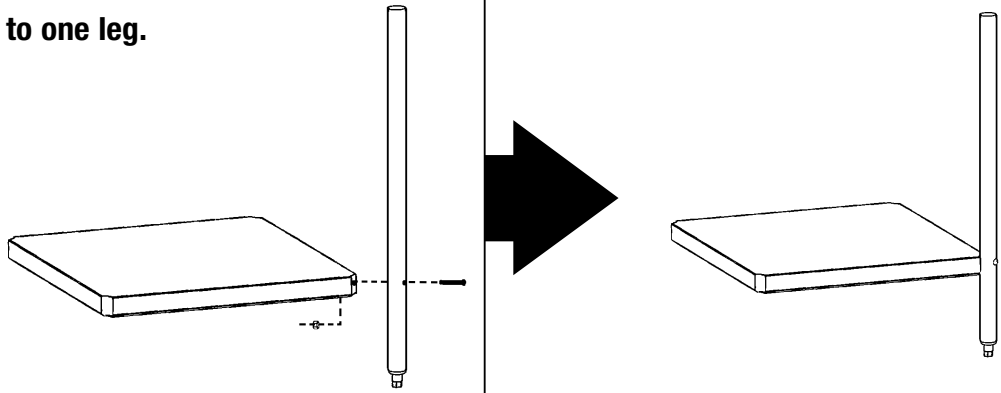

### Step 2 - Bolt remaining legs to undershef.

- Repeat **Step 1**, bolting the remaining legs to the undershef.

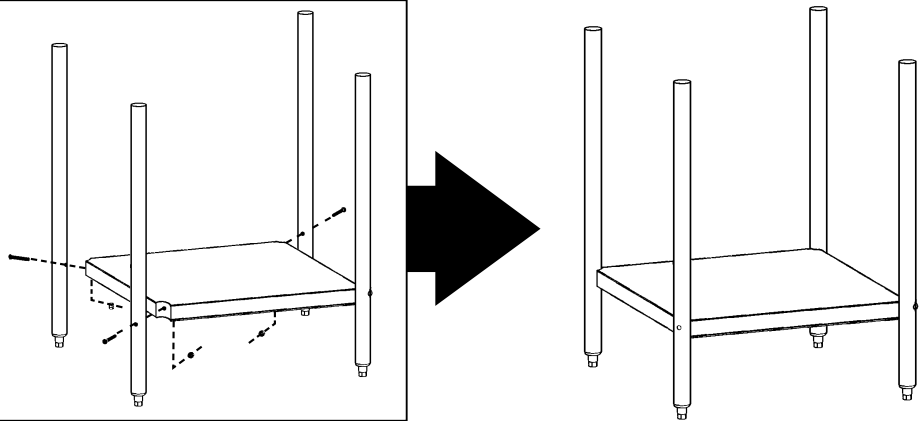

### Step 3 - Join tabletop to legs.

- Turn leg/undershef assembly upside-down.
- Turn tabletop upside-down (take care not to scratch the finish).
- Insert the top of each leg into each gusset of tabletop.
- Secure the tabletop to the legs by placing a set screw through the hole found in each gusset (see inset), and tighten.

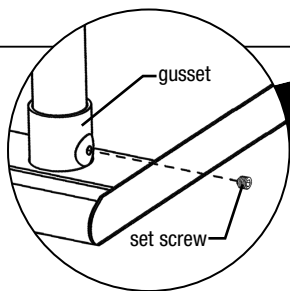
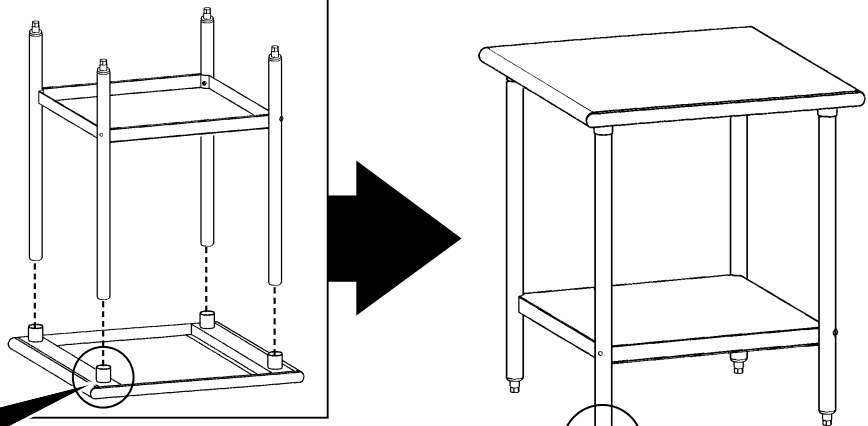

### Step 4 - Level unit.

The leveling feet allow approximately 1" adjustment.

**(End)** Assembly is complete.

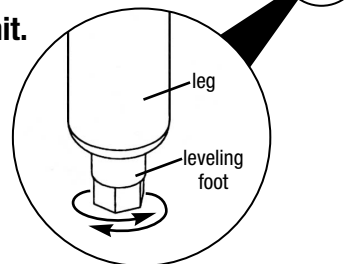

# Expansion Applicator Casters

## ASSEMBLY INSTRUCTIONS

For all Cleanroom Tables on this Instruction Sheet.

### IMPORTANT!

Before assembly, verify what caster you have...

#### Casters with installation nut underneath caster frame...

##### Step 1

Hold installation nut and tighten knurled nut until the rubber expansion applicator starts to expand.

##### Step 2

Insert caster into leg. The caster should fit snugly. If loose, go back to **Step 1**.

##### Step 3

With caster fully inserted into leg, tighten installation nut\* with a 3/4" or 19mm wrench.

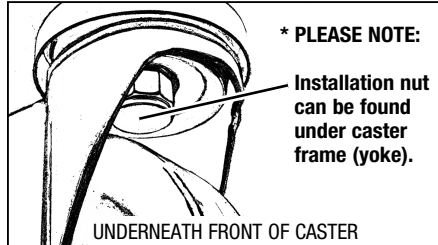
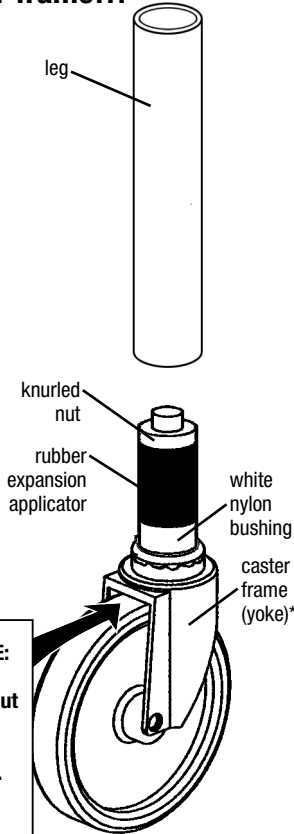

\* PLEASE NOTE:

Installation nut can be found under caster frame (yoke).

UNDERNEATH FRONT OF CASTER

**(End)** Assembly is complete.

#### Casters with installation nut on top of caster frame...

##### Step 1

Hold installation nut and tighten knurled nut until the rubber expansion applicator starts to expand.

##### Step 2

Insert caster into leg. The caster should fit snugly. If loose, go back to **Step 1**.

##### Step 3

With caster fully inserted into leg, tighten installation nut, using an adjustable wrench.

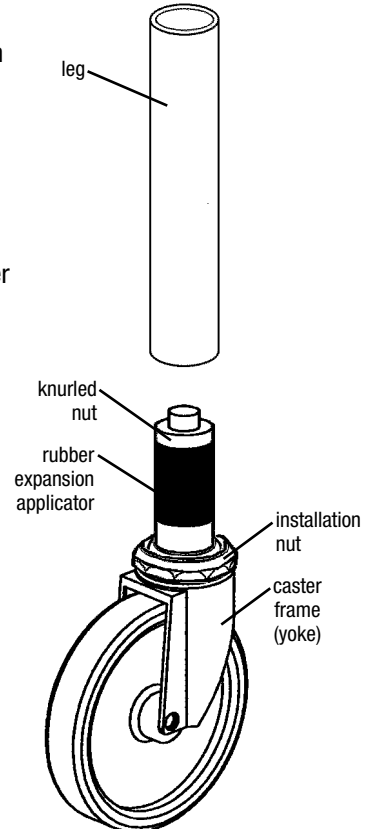

**(End)** Assembly is complete.

## CARE AND CLEANING

**CLICK HERE**  **for full information sheet**

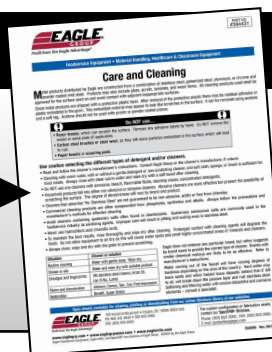

- 100 Industrial Boulevard, Clayton, Delaware 19938-8903 U.S.A.
- Phone: 302/653-3000 • 800/441-8440 • Fax: 302/653-2065
- www.eaglegrp.com • www.eaglehmc.com

Eagle Foodservice Equipment, Eagle MHC, and SpecFAB® are divisions of Eagle Group. ©2024 by the Eagle Group