

# Benchside Tote Box Carrier

## ASSEMBLY INSTRUCTIONS

### CAUTION

INSPECT CONTENTS IMMEDIATELY AND FILE CLAIM WITH DELIVERING CARRIER FOR ANY DAMAGE. **SAVE YOUR BOX AND ALL PACKING MATERIALS.** YOU ARE RESPONSIBLE FOR DAMAGE TO YOUR UNIT IF RETURNED IMPROPERLY PACKED.

Thank you for your purchase. Before assembly, read this instruction sheet carefully. After reading, be sure to store this instruction in a safe place, should it be needed for future reference.

#### Step 1 - Place donut bumper onto bottom end of each post.

Bottom is end with hole for caster stem.

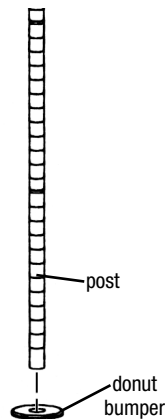

#### Step 2 - Drive in caster, using a hammer or mallet.

Several solid blows are usually required.

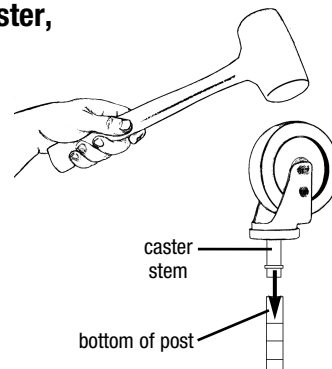

#### Step 3 - Attach split sleeves (for bottom shelf) to second from bottom groove on each post.

- The wider part of the taper goes toward the bottom.
- Make sure rib on split sleeve is seated into groove on the post.

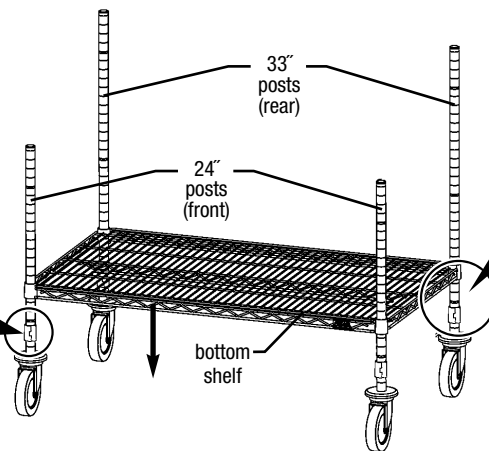
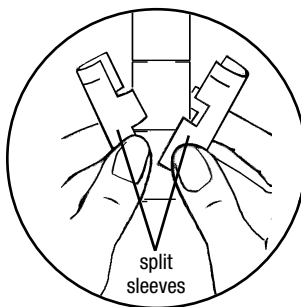

#### Step 4 - Mount bottom shelf.

- Lower shelf onto split sleeves. Make sure all shelf corners are seated.

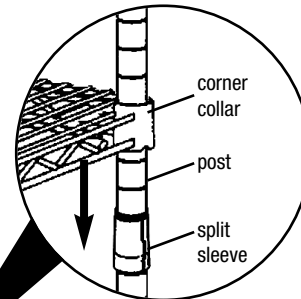

(continued on back page)

EG9885 Revised 09/23

# Benchside Tote Box Carrier

## ASSEMBLY INSTRUCTIONS

3-sided  
truss  
frame

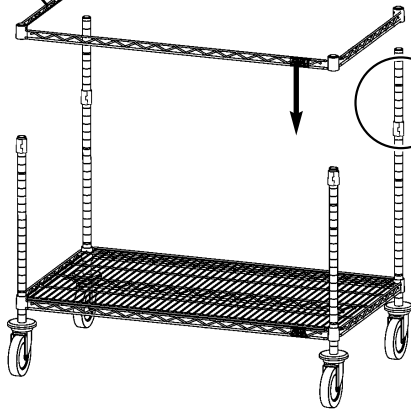

### Step 5: Attach 3-sided truss frame to posts.

- Mount split sleeves, as described in Step 3, onto top groove of front posts and groove #22 of rear posts.
- Lower 3-sided truss frame down rear posts, as shown, and snug onto split sleeves on all posts.

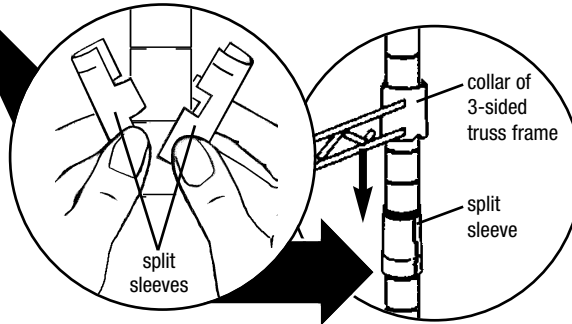

hanger  
rail

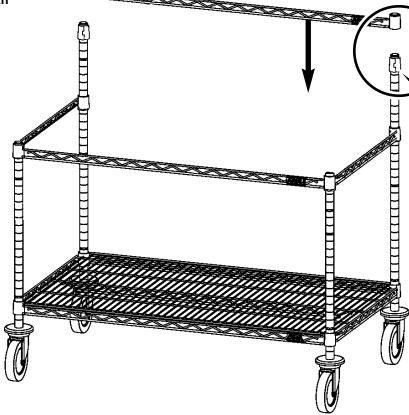

### Step 6 - Attach hanger rail to rear posts.

- Mount split sleeves onto top groove of rear posts.
- Lower hanger rail down rear posts and onto split sleeves.

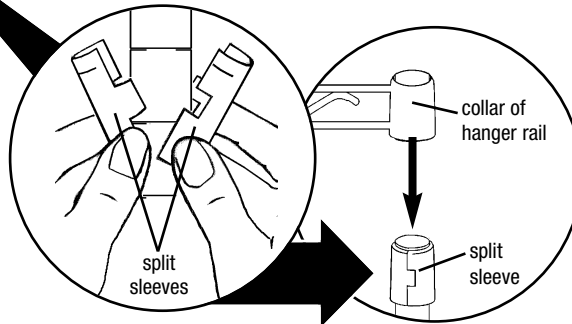

angled  
wire  
shelf

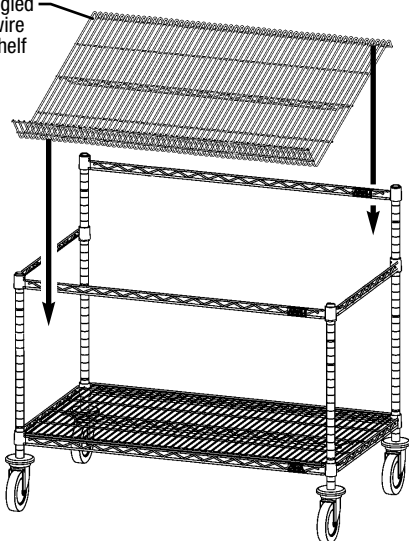

### Step 7 - Mount angled wire shelf.

*Note: 3-1/2" upturn indicates front of angled wire shelf.*

- Hook rear of angled wire shelf onto hanger rail. Front of angled wire shelf sits on the three-sided truss frame.

Assembly is complete.

(End)