

Security Units

ASSEMBLY INSTRUCTIONS

CAUTION

INSPECT CONTENTS IMMEDIATELY AND FILE CLAIM WITH DELIVERING CARRIER FOR ANY DAMAGE. **SAVE YOUR BOX AND ALL PACKING MATERIALS.** YOU ARE RESPONSIBLE FOR DAMAGE TO YOUR UNIT IF RETURNED IMPROPERLY PACKED.

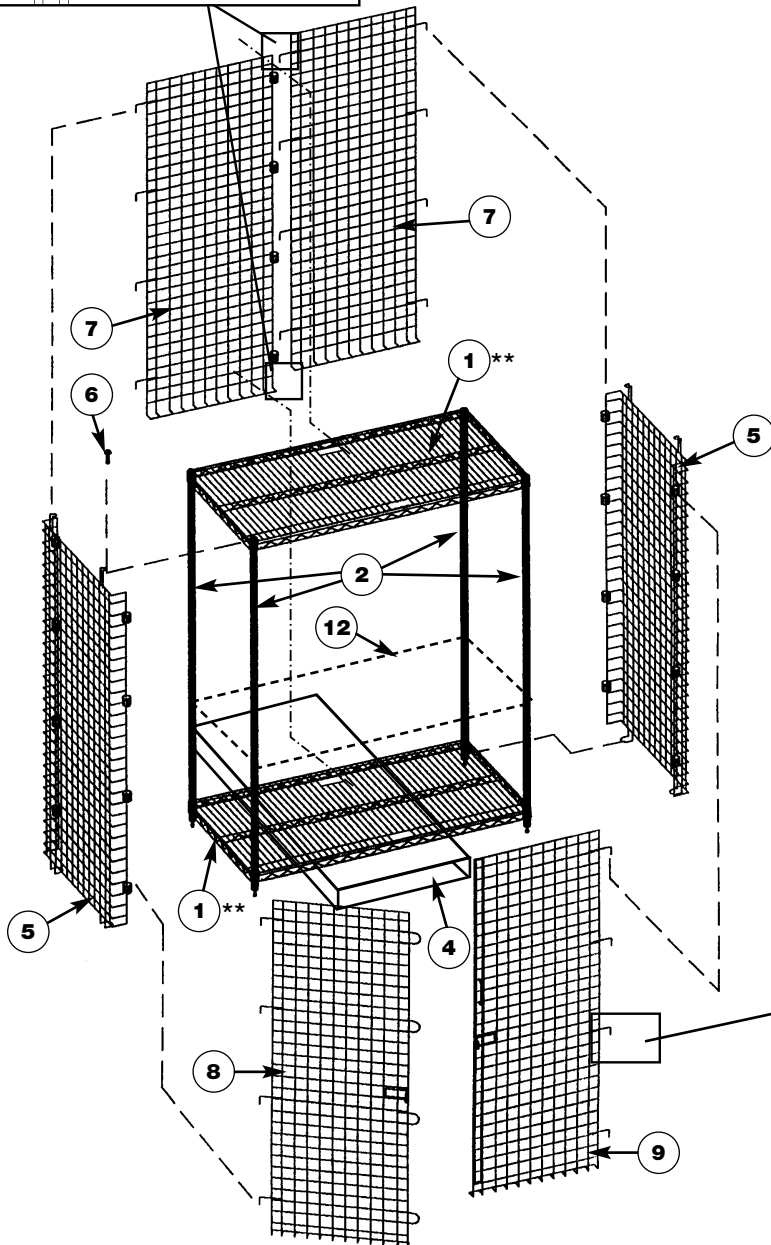
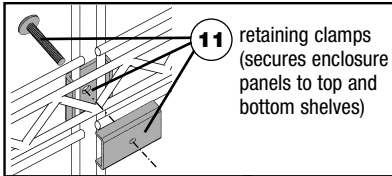

Parts List

#	qty	description
#1	2	Notched Wire Shelf **
#2	4	Posts
#3	2	(bags of four) Aluminum Split Sleeves with Retaining Rings
#4	1	Spacer Box
#5	2	End Panels
#6	4	1/4" - 16" x 1/4" Tamper Proof Bolts
#7	1	Back Panel (48" & 60" units come in two pieces)
#8	1	Left Door Panel
#9	1	Right Door Panel with Latch
#10	8	Bushings
#11	*	Retaining clamps (#A221681)
#12	*	Optional Center Shelves, if ordered.

* Varies per order.

**** IMPORTANT TO NOTE IF YOUR UNIT CAME WITH OPTIONAL CENTER SHELVES**

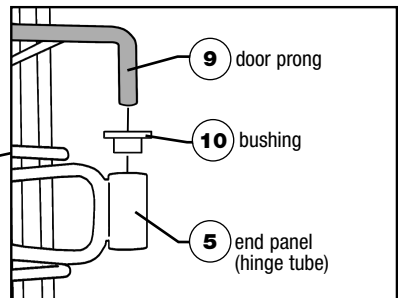
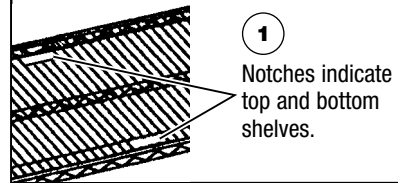

(continued on next page)

Security Units

ASSEMBLY INSTRUCTIONS

Step 1: Assemble shelves and posts, starting with bottom shelf.

NOTE: Bottom shelf must be assembled to posts **FIRST**.

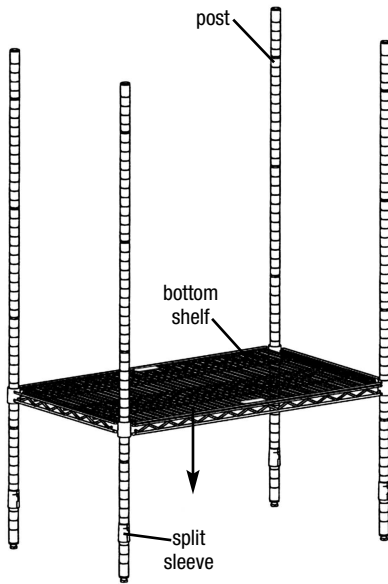

ATTACH SPLIT SLEEVES TO POSTS.

- Wider part of taper goes toward the bottom.
- Make sure rib on split sleeve is seated into groove on post.
- Set aside retaining rings until later.

MOUNT BOTTOM SHELF.

- Insert top of posts through bottom of shelf corner collars.
- Slide shelf down posts until split sleeves are seated inside corner collars.

DO NOT SECURE YET!

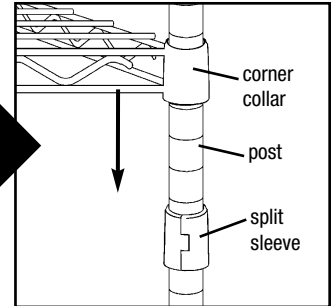
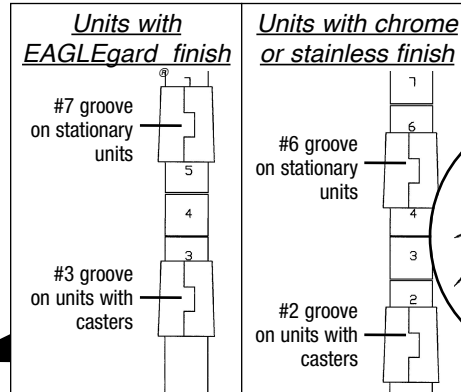

IMPORTANT: IF YOU HAVE OPTIONAL CENTER SHELVES, THEY MUST BE INSTALLED **IMMEDIATELY** AFTER INSTALLING BOTTOM SHELF. REPEAT **STEP 1** TO MOUNT OPTIONAL CENTER SHELVES (IF ANY), WORKING FROM BOTTOM TO TOP.

REPEAT **STEP 1** TO MOUNT TOP SHELF.

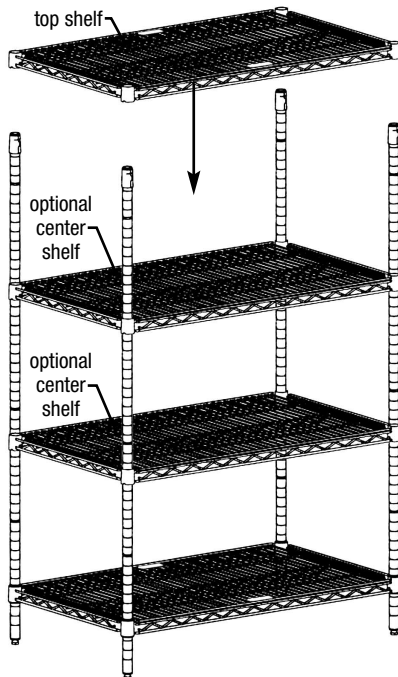

Step 2: Secure center shelves (if any) and top shelf.

DO NOT SECURE BOTTOM SHELF YET.

PLACE A BOARD ACROSS SHELF CORNER AND GENTLY TAP WITH HAMMER OR MALLET.

- Do NOT hammer directly on wire or corner.

APPLY SPLIT SLEEVE RETAINING RINGS.

- Make sure the groove, located on top of split sleeve, is accessible.
- Gently tap ring into the groove of each split sleeve.

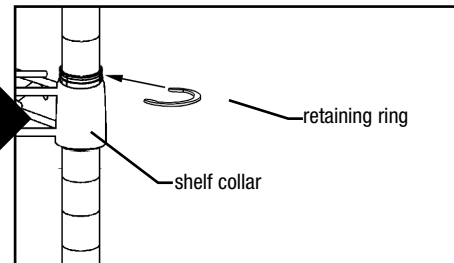
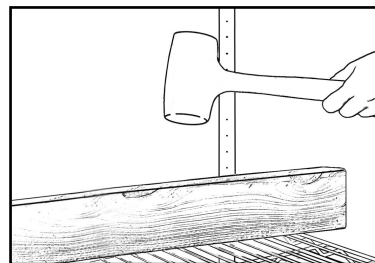

(continued on next page)

Security Units

ASSEMBLY INSTRUCTIONS

Step 3: Attach end panels.

NOTE*: *Additional standard shelves cannot be added once the end panels are in place.*

* Add-A-Shelf® and Quad-Adjust® shelves can be added after assembly. Contact Eagle Group for more information.

TEMPORARILY RAISE BOTTOM SHELF.

- Place assembled shelf unit over spacer box (same box the shelves were packed in).
- Lift bottom shelf off split sleeves, so shelf rests on spacer box and posts touch the floor.

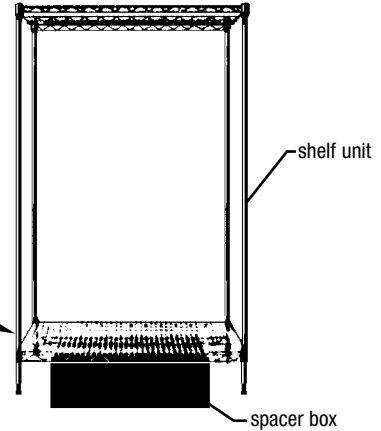
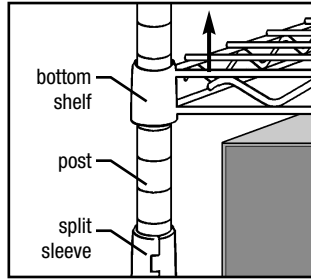

ATTACH END PANELS TO UNIT.

- Place end panels in position.
Note: Large loops should be at the bottom, small loops at the top.
- Tip unit slightly so bottom loops of end panel can slide under bottom of front and rear posts.
- Lift enclosure panel and position top loops over top of front and rear posts.
- Secure end panel in place, using "one-way" bolts.

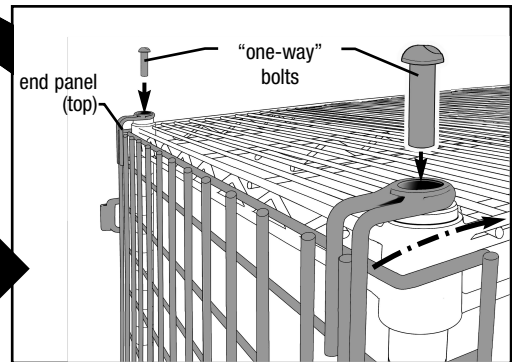
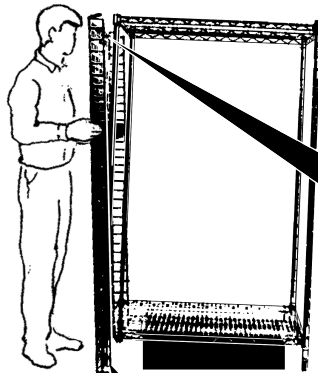

Note: For stainless steel units, use provided tamper-resistant #14 spanner insert bit to install bolts.
IMPORTANT: *If using drill to assemble, USE DRILL AT LOW POWER SETTING.*

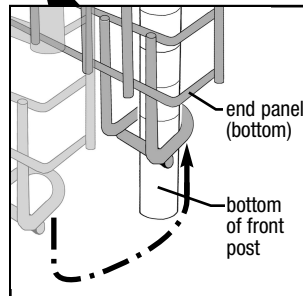

REPEAT **STEP 3** TO ATTACH REMAINING END PANEL.

Step 4: Attach rear panel(s).

- Place rear panel(s) in position. Insert rear panel prongs into end panel hinge tubes as shown below.
Note: 36" units have one panel, 48" and 60" have two panels.

- Use the retaining clamps to secure back panel(s) to top shelf (**do NOT secure bottom shelf yet**).

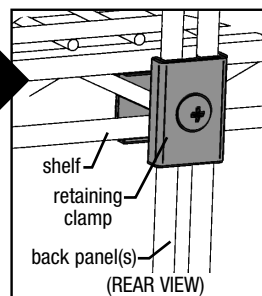
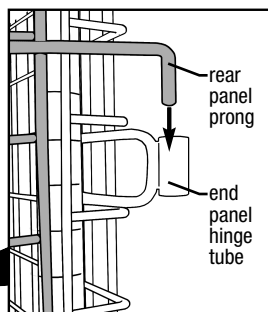
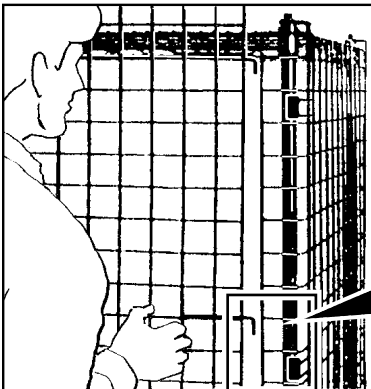

(continued on back page)

Security Units

ASSEMBLY INSTRUCTIONS

Step 5: Secure bottom shelf.

- Remove spacer box and lower bottom shelf onto split sleeves.

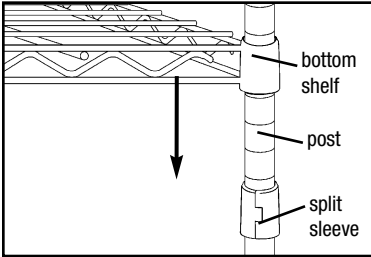

- Place a board across each corner and tap with hammer or mallet.

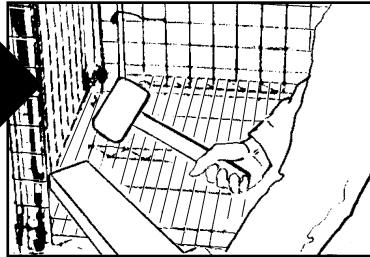

- Gently tap split sleeve retaining ring into groove of each split sleeve.

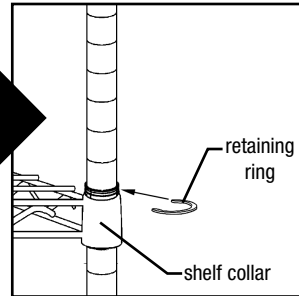

FOR SIDE-TO-SIDE LENGTHS MORE THAN 36":

- Secure back panel(s) to bottom shelf using retaining clamps.

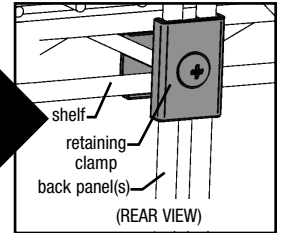

IF YOUR UNIT IS STATIONARY AND DOES NOT HAVE CASTERS OR DOLLY TRUCK, SKIP **STEP 6** AND PROCEED TO **STEP 7**.

Step 6: Attach casters or dolly truck to unit.

IF YOUR UNIT HAS CASTERS:

- Gently lay unit on its side.
- Insert caster stem into bottom of each post, and tap with mallet. This may require several taps.
- Stand unit upright onto casters.

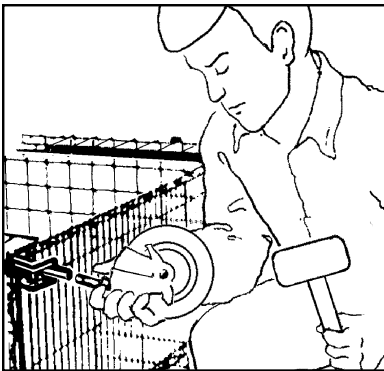

IF YOUR UNIT HAS A DOLLY TRUCK:

- Stand unit onto dolly truck.
- From underside of dolly truck, run bolts (provided) through dolly truck and fasten into bottom of posts.

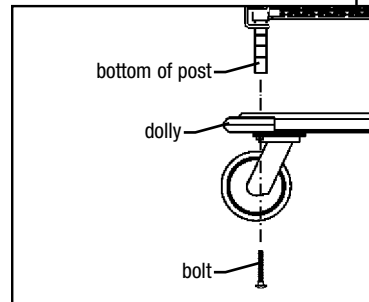

Step 7: Attach door panels.

- *Note: Insert bushings (provided) into hinge tubes of end panels BEFORE installing doors.*
- Hang left door panel and right door panel.

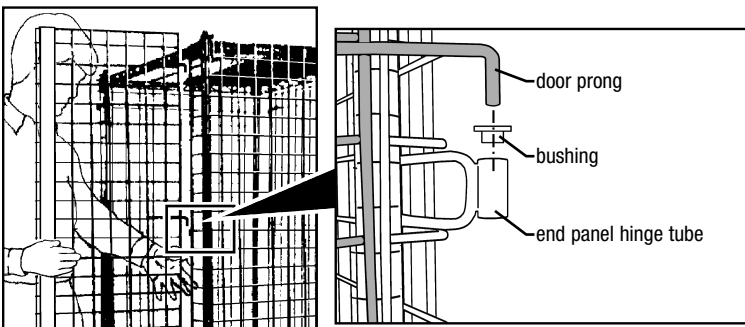

TO CLOSE DOORS:

- Push left-hand door shut.
- Right-hand door features movable latch. Move latch upward, push door shut, then move latch downward. Latch hooks into top and bottom shelves, keeping both doors closed.

(End)



- 100 Industrial Boulevard, Clayton, Delaware 19938-8903 U.S.A.
- Phone: 302/653-3000 • 800/441-8440 • Fax: 302/653-2065
- www.eaglegrp.com • www.eaglemhc.com

Eagle Foodservice Equipment, Eagle MHC, and SpecFAB® are divisions of Eagle Group. ©2024 by the Eagle Group