

ASSEMBLY INSTRUCTIONS

CAUTION

INSPECT CONTENTS IMMEDIATELY AND FILE CLAIM WITH DELIVERING CARRIER FOR ANY DAMAGE. **SAVE YOUR BOX AND ALL PACKING MATERIALS.** YOU ARE RESPONSIBLE FOR DAMAGE TO YOUR UNIT IF RETURNED IMPROPERLY PACKED.

Parts List

qty/unit part # description

Overhead Track Units

- #1 . . . * channel
- #2 . . . * stainless steel channel support

Stationary Units

- #3 . . . 4 post for stationary units
- #4 . . . 4 A214233 . . . foot plate for stationary units

Mobile Units

- #5 . . . 2 * roller assembly for mobile units
- #6 . . . 4 * posts for mobile units
- #7 . . . 4 A200019 . . . donut bumper
- #8 . . . 2 * rigid caster channel
- #9 . . . 4 A204177 . . . rigid caster for mobile units

qty/unit part # description

Hardware for Overhead Track Unit's Channel Supports

- #10 . . 12** A203811 . . . flat head screw: 1/4-20 x 3/4"
- #11 . . 12** 313895 . . . flat washer: #10 stainless steel
- #12 . . 12** 310481 . . . acorn nut: 1/4-20

Hardware for Stationary Units

- #13 . . 4 303999 . . . hex head bolt: 3/8-16 x 1 1/4", for stationary units

Hardware for Mobile Units

- #14 . . 4 300756 . . . round head screw: 8-32 x 3/8", for mobile units

Other

- #15 . . * * wire shelf (sold separately)

*Quantity and/or size will vary per order; **Only applicable when assembling more than one channel per side.

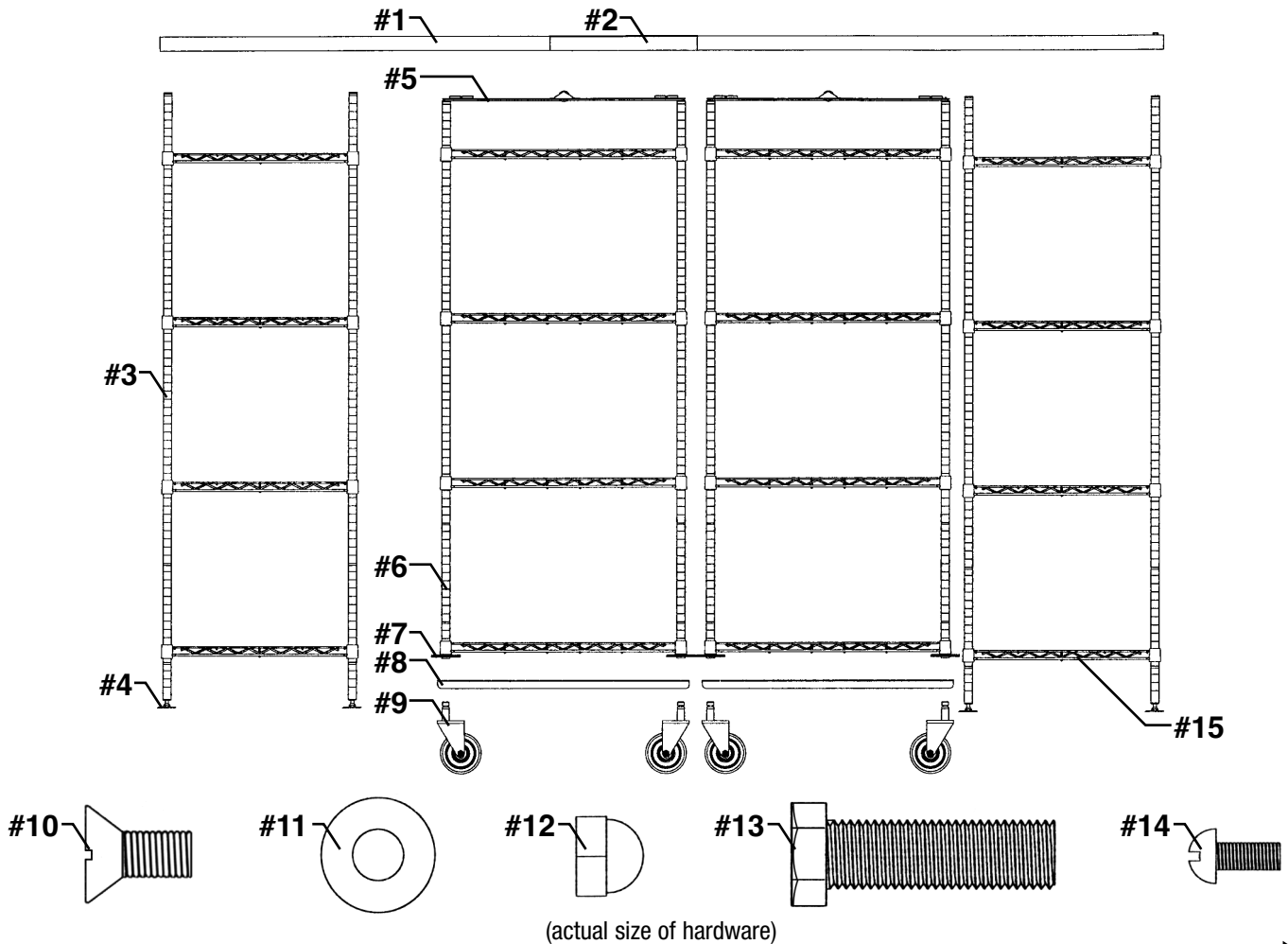

(continued on Page 2)

ASSEMBLY INSTRUCTIONS

Before assembly, please note:

- Clean the inside of the channels.
- Stationary Units must be bolted to the floor. Hardware not included.
- 14" Mobile Units not recommended as there is a possibility of tipping.
- Floor must be flat and free of cracks for proper operation.
- Bearings do not require lubrication.

Step 1 - Assemble stationary units per wire shelving instructions.

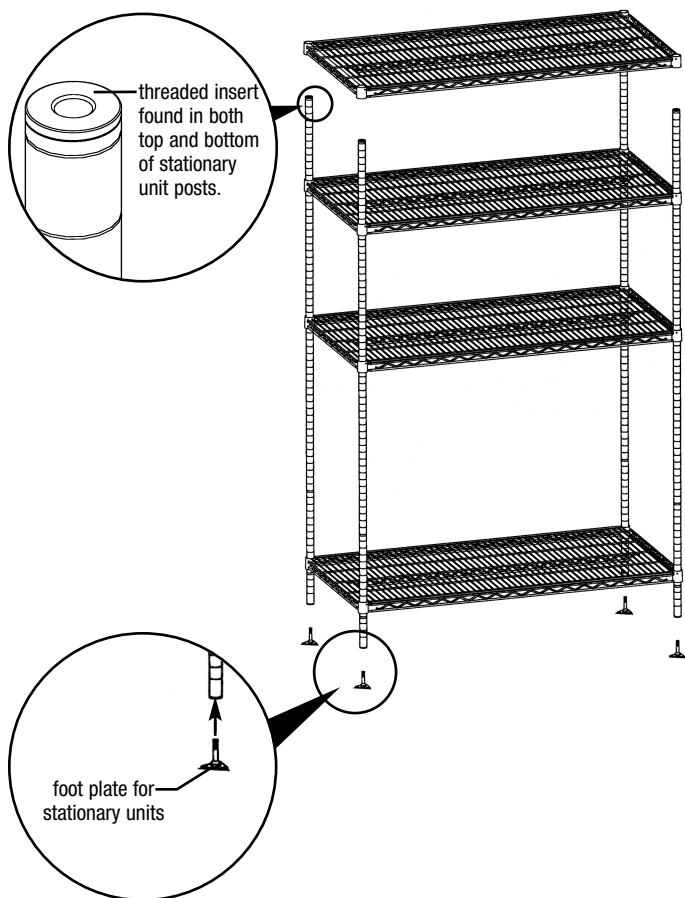

Step 2 - Assemble mobile units per wire shelving instructions.

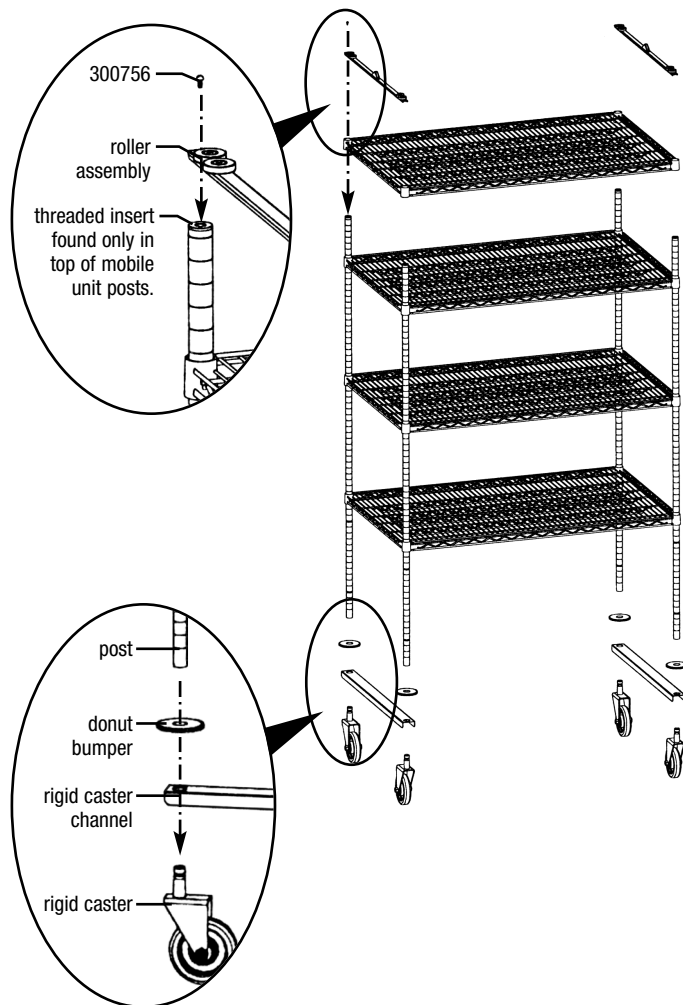

(continued on Page 3)

Master Trak®

ASSEMBLY INSTRUCTIONS

Step 3 - For overhead track units with more than one channel per side, bolt units together.

(Note: This pertains to tracks units 10' and longer. For tracks units up to 9' long, skip this step and go to Step 4.)

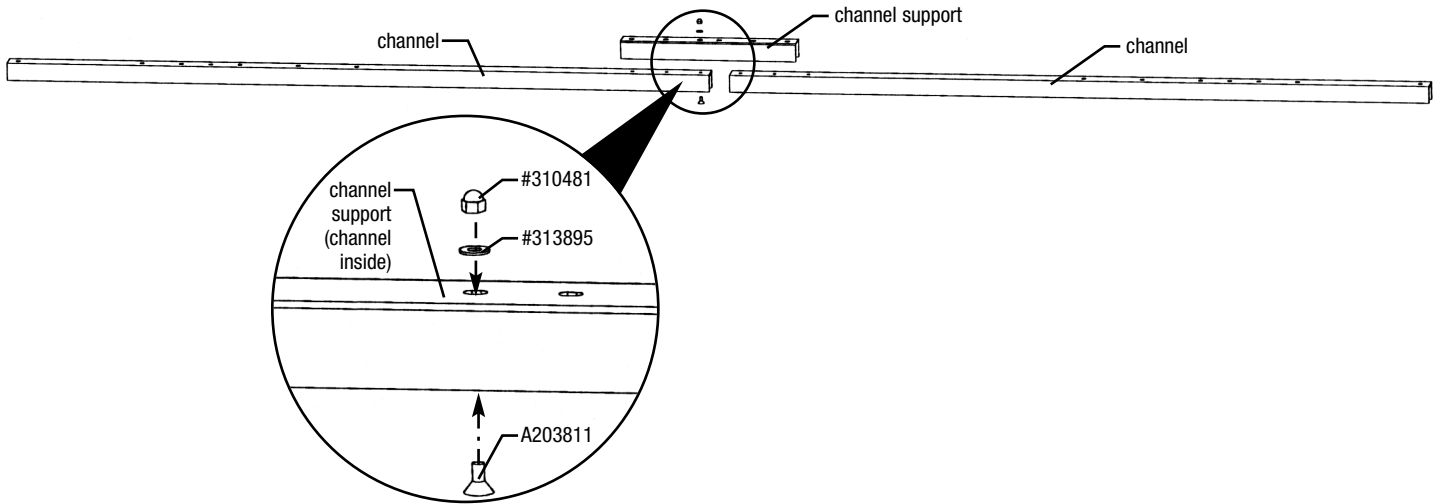

Step 4 - Align the stationary and mobile units to desired location, and mount the overhead tracks to the top of the stationary units.

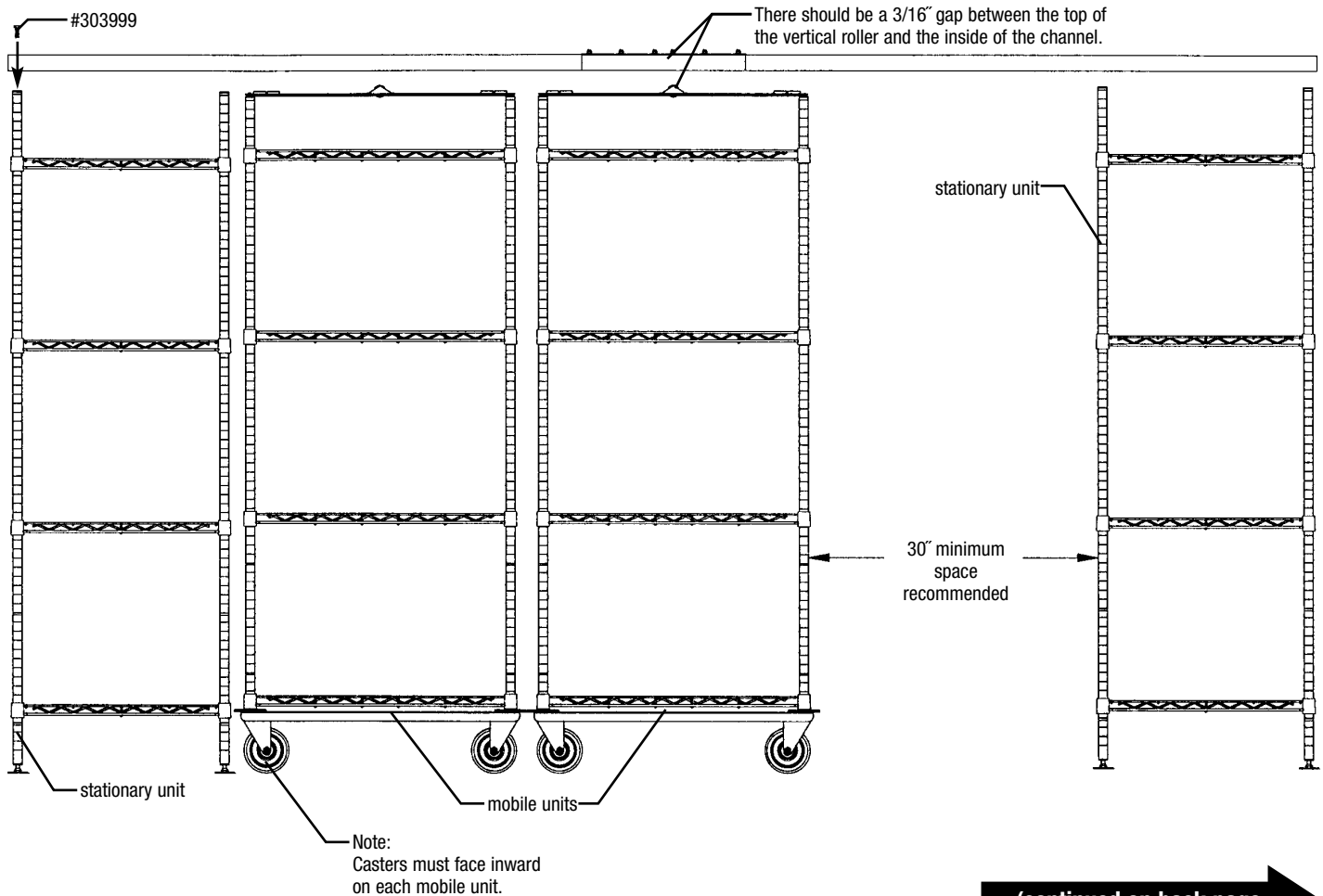

(continued on back page)

Master Trak®

ASSEMBLY INSTRUCTIONS

Step 5 - Create a positive arc in the overhead track by adjusting the foot plates on the stationary units.

Once this arc has been achieved, bolt all foot plates to the floor (hardware not included).

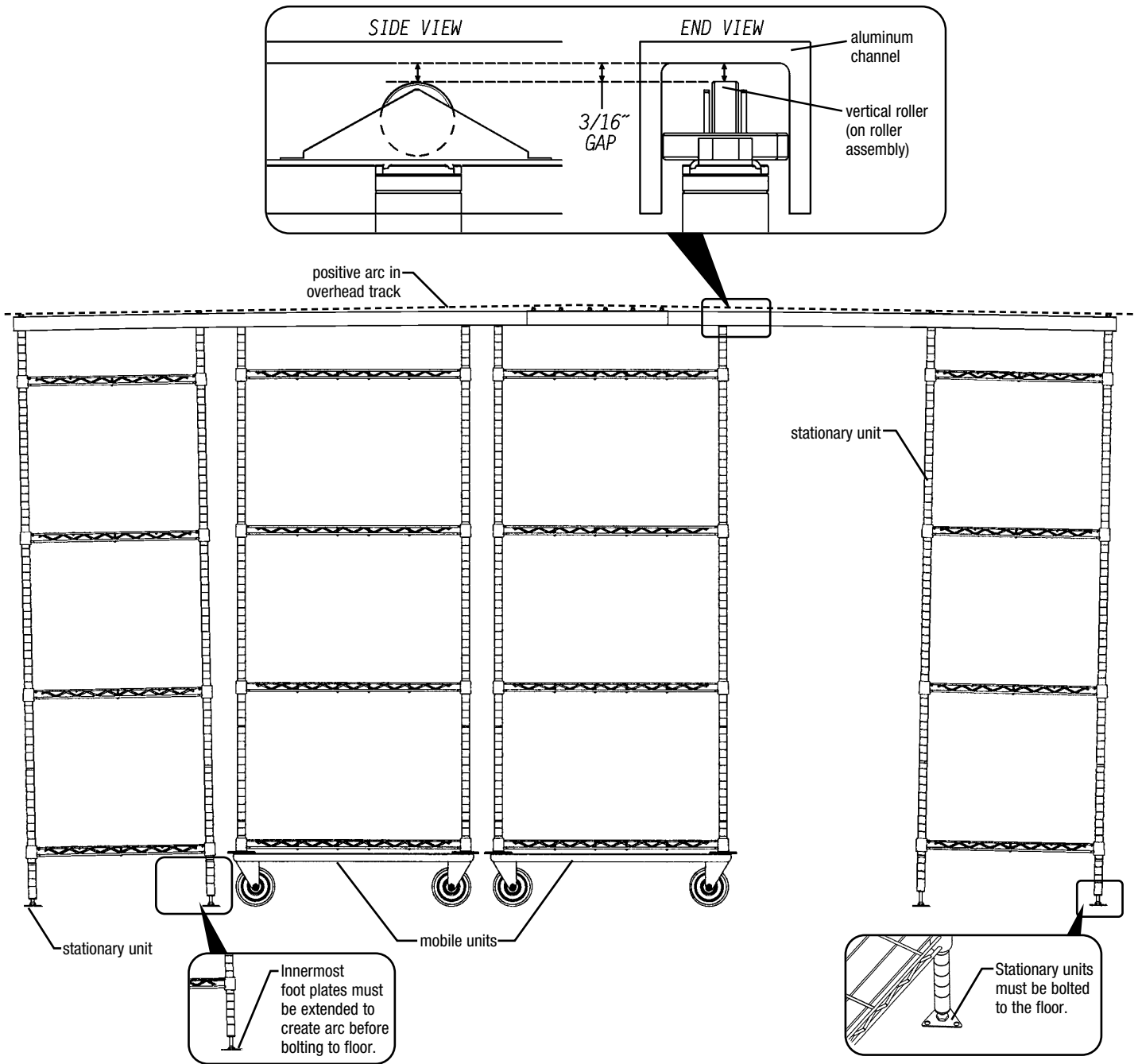

(End)