



LABORATORY

- WIRE SHELVING
- STAINLESS STEEL CASEWORK
- COUNTERTOPS
- HEIGHT ADJUSTABLE TABLES
- STAINLESS STEEL SINKS
- WALL SHELVING
- PEGBOARDS

CLEANROOM FURNISHINGS

- WORKSTATIONS
- TABLES
- FOOT RESTS
- SINKS
- GARMENT RACKS
- GOWNING BENCHES
- CARTS

PRODUCTS FOR LIFE SCIENCE

PHARMACEUTICAL - BIOTECH - MEDICAL DEVICE - CLEANROOM - LAB - RESEARCH



EAGLETM
MHC Division

Material Handling, Healthcare & Cleanroom Equipment

P: 1-800-441-8440

F: 302-653-2065

WWW.EAGLEMHC.COM

Quad-Truss® Wire Shelving

The patented Quad-Truss® system makes shelves up to 25% stronger, and provides a retaining ledge for increased strength and product retention. Available with a variety of finishes (listed at right). EAGLEgard® epoxy finish standard with MICROGARD®, an antimicrobial agent which contains built-in protection to retard the growth of a broad range of bacteria, mold and mildew on the surface of the shelves that cause stains, odors and degradation.

EAGLEgard® epoxy finish features
MICROGARD®
antimicrobial protection

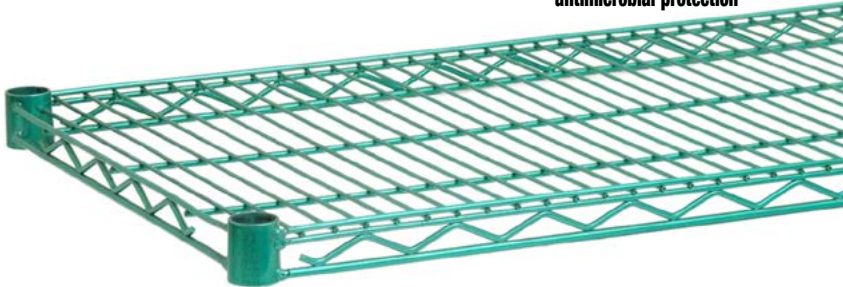

Quad-Truss® Wire Shelving

Shelves feature special interlocking corners that fit in slots of collars mounted to split sleeves, allowing addition or removal of a shelf without the need to disassemble the entire shelf unit.

Utilizes the patented Quad-Truss® system (patent #5,390,803) which makes shelves up to 25% stronger, and provides a retaining ledge for increased strength and product retention. Available in a variety of finishes (listed at right). Accommodates all standard wire shelving accessories.



Easy Assembly...

- Numerically calibrated grooved posts, tapered plastic split sleeves and shelf collars combine to make shelving assembly a simple two step process: 1) Snap the split sleeves onto the post over the number of your choice; 2) Slide the shelf collars over the split sleeves. A positive lock between shelf and post is created without the use of any tools.
- Tapered split sleeves of high-temperature-resistant ABS plastic create a positive lock that becomes stronger as the load increases.
- Posts are numbered in 1" increments to ensure fast and level assembly.
- Leveling feet are provided to help compensate for uneven floors.



split sleeves

Finish Warranties

Stainless Steel finish—OUR BEST

• Stainless steel
NSF-listed for all environments. Type 304 stainless steel. **15 Year Warranty**

Eaglegard® hybrid epoxy

• Zinc chloride
• Clear chromate
• MasterSeal® sealer
• Blue green (translucent)
hybrid epoxy with MICROGARD®
NSF-listed for all environments.
Zinc chloride plating followed by clear chromate plating with MasterSeal® sealer and a hybrid translucent epoxy combined with MICROGARD®.
15 Year Warranty

• Phosphate conversion coating
• MasterSeal® sealer
• Pewter gray epoxy
NSF-listed for dry/wet storage and dry heated environments. Phosphate conversion coating with MasterSeal® sealer for improved rust protection, followed by metallic gray epoxy coating.

Valu-Gard® epoxy

• Phosphate conversion coating
• MasterSeal® sealer
• Green (opaque)
hybrid metallic epoxy
NSF-listed for dry/wet storage and dry heated environments. Phosphate conversion coating with MasterSeal® sealer for improved rust protection, followed by metallic green epoxy coating.
5 Year Warranty

Chrome

• Bright nickel
• Chrome
• Air-dry lacquer
NSF-listed for dry storage and heated environments. Bright nickel plating followed by chrome plating.
1 Year Warranty
(NOTE: Optional clear hybrid epoxy, NSF-listed for all environments, is available.)

Eaglebrite® zinc

• Zinc chloride
• Clear chromate
• MasterSeal® sealer
• Air-dry lacquer
NSF-listed for dry storage and heated environments. Bright zinc chloride plating followed by clear chromate plating with MasterSeal® sealer for improved rust protection. **3 Year Warranty**
(NOTE: Wire shelves feature MasterSeal® sealer. Posts feature air-dry lacquer, NSF-listed for all environments.)

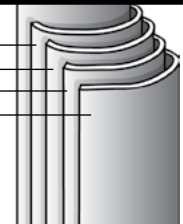
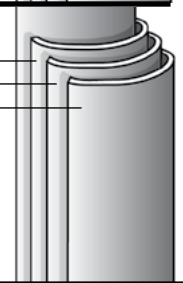
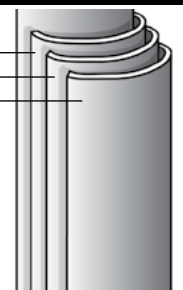
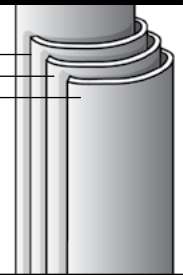
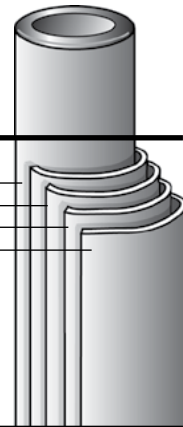

Security Units

Full-Size Security Units

- Safely store and transport costly materials subject to pilferage.
- Available in chrome, EAGLEgard®, green epoxy and stainless steel.
- Styles include stationary, mobile, and units with dolly trucks.
- Additional center shelves and optional pre-assembly available.



Custom Application

Security Modules

- Converts portion of existing shelving into a lockable security unit.
- Kit includes end panels, rear panes and door(s).
- Two door styles available, hinged or flip-up.
- Modules fit between 2 wire shelves spaced 20" apart.
- More than one module can be added depending on unit's overall height.
- Available in zinc, chrome, EAGLEgard® green epoxy and stainless steel.



security module with flip-up door shown assembled to wire shelf unit



security module with hinged doors shown assembled to wire shelf unit

NOTE: Shelves and posts sold separately.

Stainless Steel Casework

Stainless Steel Inset Casework



Stainless Steel Vertical Storage Cabinets



- All Type 304 stainless steel construction.
- Four adjustable intermediate shelves.
- Stainless steel hinged doors with wire-style pulls.
- Stationary and mobile units available.

Pegboards

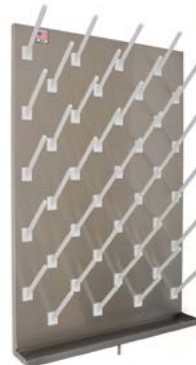

- Heavy gauge 304 stainless steel construction.
- Comes standard with 6" white polymer pegs.
- Wall mounting bracket included.
- 2" or 4" integral drip trough comes with 36" long clear flexible drain tubing



ECE Series

ECE Series Exchange Carts

- Includes five chrome-plated wire shelves.
- Chrome-plated posts with chrome dolly frame and wraparound bumper.
- 8" polyurethane casters (two with brake).
- Side and back enclosure panels, one or two slide assemblies, two or four tote boxes 6" deep with box dividers, four or six shelf dividers, and 12 plastic shelf markers.
- 72" overall height.

Note: "ECES Series" also available, which is the same except the fifth wire shelf is replaced by a stainless steel solid shelf.



ECDT Series

ECDT Series Exchange Carts

- Four chrome-plated wire shelves and choice of chrome-plated wire or stainless steel solid fifth shelf.
- Chrome-plated posts, three slide assemblies, six tote boxes with box dividers with 6" polyurethane casters (two with brake).
- Three shelf dividers, six plastic shelf markers, and a chrome dolly frame with wraparound bumper. 60" shelf length.
- 70" overall height.



Tote Box Carriers

Accommodates a wide variety of containers.

- Each tote box carrier comes with two brake and two swivel casters.
- One-, two-, or three-bay carrier models available with standard resilient or poly casters.

Overhead Track High-Density Storage System

- Maximum storage in a minimum amount of space.
- Requires only single-aisle access.
- Allows longer track length without a stationary intermediate unit.
- Quick and easy assembly.
- Offered in a wide selection of sizes, with shelves ranging from 18' to 36' wide and 24' to 72' long, and overhead track ranging from 6' to 21' long.



*Now patented, unique roller assembly provide smooth operation without binding, which can occur in other track systems.
Patent #5,680,942*



multiple unit configuration

Floor-Trak® High-Density Storage

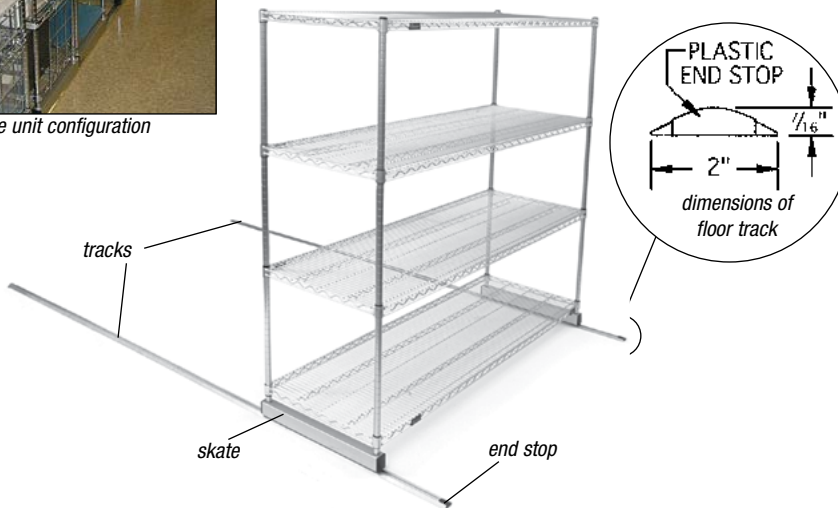

*single deep unit shown assembled with wire starter unit
(wire shelving unit sold separately)*

- Industrial-type bearings allow loaded units to glide effortlessly over track.
- Low profile, non-corrosive track constructed of stainless steel and anodized aluminum.
- Consolidates space.
- ADA compliant.
- Simple and easy to install.
- Can be built double deep and not impede rollability.
- Easy to add-on additional tracks and units.
- Open construction allows for the use of cart covers when required.

Floor-Trak® Units shown with QuadPLUS® Polymer Shelf Mats



QuadPLUS® Polymer Shelf Mats

Mats come with choice of...

**Easy Assembly!
No tools needed!**

Mats snap in place!



removable shelf mats shown with Quad-Adjust® wire truss frame

polymer shelf mats available!

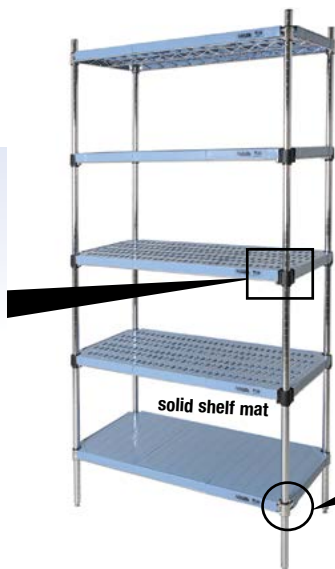

shelf mats—blue, louvered and solid —shown assembled to shelf unit



Quad-Adjust® Truss Frame...
Allows the addition or removal of a shelf without having to disassemble the entire shelf unit.



...or Standard Wire Truss Frame

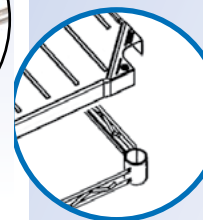

Step 1
Position polymer mats onto wire truss frame or shelf accordingly.

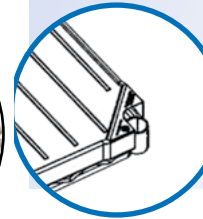

Step 2
Gently push each mat down along the front and rear to snap them into place.

NEW!

PPE Dispensers

All units feature #4 brushed finish type 304 stainless steel construction. Compartment size and quantity can be customized to specific needs.



Eye Protection Holder

Compartments are sized for safety glasses and may be customized for goggles and other PPE. Compartments are 3¼" wide, 2¾" high, and 6½" deep.



Open Garment Dispenser

Single compartment is 14⅞" wide, 30" tall, and 10" deep. Compartment is sized for folded garments, such as scrubs, gowns, and aprons.



Closed Garment Dispenser

Single compartment is 12¼" wide, 22" tall, and 7⅞" deep. Compartment is sized for folded garments, such as scrubs, gowns, and aprons. May be customized for specific sizes.



Glove Dispenser
Single compartment is 8⅞" wide, 17" tall, and 8" deep.

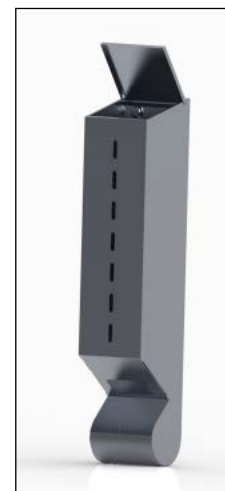

Glove Dispenser with Catch Basin
Single compartment is 8⅞" wide, 39" tall, and 8" deep.

NEW!

Laboratory Exhaust Canopies

Island or wall mount exhaust canopies feature 16 gauge type 304 stainless steel construction, fully welded seams, polished interior and exterior, steel rod suspension brackets, full perimeter condensation edge, 19" overall height, and integral duct collar. Exhaust canopies are available in 30" and 36" depths, and widths ranging from 36" to 96".



wall hood



island hood

Cleanroom Applications



EAGLE GROUP's cleanroom line offers wire shelving with superior strength - while at the same time allowing for 62% laminar flow. EAGLE GROUP offers the preferred transport and storage vehicle by providing numerous ergonomic and visual advantages, and does not hold particulates. Numerous options allow customization for any environment or situation. The open-wire construction promotes higher visibility by allowing light to pass through the shelves, permits greater air circulation reducing dust and contamination buildup, and increases the effectiveness of fire-suppression systems.

Wire Freestanding Gowning Racks

- These racks incorporate standard wire shelving components with specially designed gown storage options.
- They offer a more economical rack option in less demanding environments.
- Racks available in chrome or stainless steel.



Wire Wall Mounted Gowning Racks

- Models with hanger slots, hanger tube, or hook rack available.
- All racks feature standard wire shelf and wall mount brackets.
- Available in chrome or stainless steel.



Perforated Gowning Benches

- Perforated seat with wire undershelf provides superior laminar flow.
- Wire undershelves offer optional bootie storage.
- Optional dividers and additional wire undershelves.
- Available in No. 4 brushed stainless steel.



shown with additional undershelf and optional dividers

Solid Gowning Benches

- 14 gauge type 304 stainless steel.
- Available in both standard and heavy duty designs.
- Stainless steel legs and footplates.
- Stainless steel legs and feet.
- Heavy duty models available with welded or adjustable H-frame or 4-sided frame.



Cleanroom Applications



Roll Bag Dispensers

- Standard unit features two 14" x 48" wire shelves, one 3-sided channel frame, eight removable dispensing bars, and four post with 30" outrigger feet.
- Dispenser bars are adjustable on 1" increments.
- Available in stainless steel or chrome finish.

Shoe Racks

- Wire shelves offer the optimum combination of laminar flow and ventilation for the storage of cleanroom shoes.
- Rods & tabs run through shelves to create cubbies for each pair of shoes.
- Available finishes are chrome and stainless steel.



Stainless Steel Worktables



adjuSTable® Work Surface Systems



Adjustable Undershelves



1-tier unit with optional grid panel



2-tier unit

patented
QuadTruss[®]
design

(Patent #5,390,803)

- Customize workstations to meet your needs.
- Choose from additional wire undershelves, solid undershelves, wire overshelves, keyboard drawers, wire grids, hanging baskets, hooks, bin holders, dividers, ledges, casters, and power strips.
- Tops available in 16/304 or 14/304 stainless steel.
- For chair or stool accessibility, choose an H-frame or C-frame.



Wall Mounted Tables

- Available in 16 or 14 gauge on 304 or 316 series stainless steel.
- Integral sink bowls, drawers, and end splashes available.
- Optional latex sound deadening.
- Facilitates small rolling cabinets which can be moved in and out.

Optional Table Edges



wall mounted table with marine counter edge

Stainless Steel Worktables

Lab Worktables

- Spec-Master® workstations feature a 14 or 16 gauge stainless steel top.
- All workstations are available with an adjustable stainless steel undershelf or tubular base.
- Left and right ends are turned down 90° providing a flat surface so tables can be placed end to end.
- Sound deadening insulation tape runs between hat channel and table top.
- All workstations feature our patented uni-lok® system which provides greater strength and a bullnose edge on front and rear (without backsplash).



Mobile Table with Flex-Master® and Drawer

- A unique custom-style overshelf system utilizing standard components.
- 10" and 12" shelf widths can be intermixed on same posts.
- Overshelf height adjustable on 1" increments.
- Unsurpassed style, strength, performance and flexibility.
- Customize your table with an appropriate sink.



patented uni-lok® system
(Patent #5,165,349)

Patented uni-lok® (patent # 5,165,349)

Our uni-lok® gusset system recesses and welds the gusset to the backing plate channel so that legs have unmatched strength and stability.

Increased Stability -

The gussets are recessed into the channels to minimize lateral movement.

Exclusive Design -

The uni-lok® is patented and unmatched in the industry.

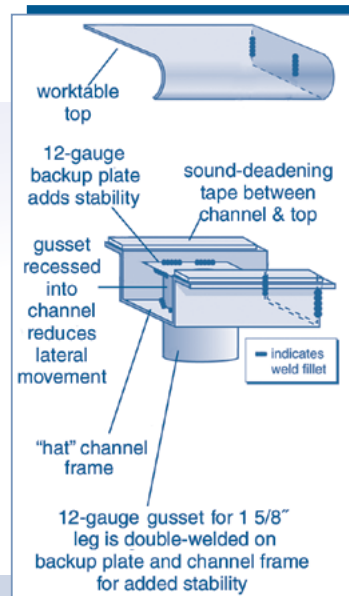

Cleanroom Tables

Available with solid or perforated tops. Perforated tops allow up to 40% laminar flow depending on size. All tops are 14 gauge type 304 stainless steel. Cleanroom tables are alcohol wiped and bagged.

- CRT SERIES (Brushed stainless solid top)
- CRPT SERIES (Brushed stainless perforated top)

- > Choose H-frame or C-frame.
- > Undershelf can be solid or perforated.
- > Knocked-down or welded construction.



patented uni-lok® system
(Patent #5,165,349)

Laboratory Shelves and Foot Rest



with upturned bookends



with downturned bookends

Laboratory Wall Shelves

- 16 gauge stainless steel shelves, with center hat channel and 1¼" rear upturn
- Adjustable on 1½" increments
- 36" tall, 1" square tubular uprights

Foot Rests

- Heavy gauge stainless steel all-welded construction.
- 1" square tubular welded frame, with non-slip rubber feet.
- Platform at 12° angle.
- Adjusts from 4½" to 9¾" (lowest leading edge to the floor).



Worktables/Workstations

Pinned Leg Adjustable Height Tables



- 2" square legs with leveling mount.
- Adjustable from 30" to 37" height.
- 22" or 28" depth.

Electronic Drive Adjustable Height Tables



- 2" square legs with leveling mount.
- 29" to 40" height adjustment.
- Electromechanical drive in each leg.
- 22" or 28" depth.

Lab Sinks

FN Series

- 14 gauge stainless steel throughout.
- All bowls are 14" deep and have 5/8" radius corners, both vertical and horizontal.
- Legs are crossbraced front-to-back and side-to-side to increase stability.
- Standard 10" backsplash and includes a 1" upturn.
- Sinks come standard in one, two, three, or four compartments with or without drainboards.



- faucet sold separately

314 Series

- 14" deep drawn sink bowls have a generous radius and are rectangular for maximum capacity.
- Legs are galvanized, 1 5/8" diameter and welded adjacent to sink bowl for maximum stability and support.
- Sinks come standard in one, two, three, or four compartments with or without drainboards.



- faucet sold separately

Counter Drop-in Self Rim Design

- Hand sinks are type 304 stainless steel all-welded construction.
- Deep-drawn, one-piece, seamless bowls.
- Available in wall mount and pedestal type models.



HSA-10-FE
hand sink

HSA-10-FDPEE-WH
hand sink

Hand Sinks

- Hand sinks are type 304 stainless steel all-welded construction.
- Deep-drawn, one-piece, seamless bowls.
- Available in wall mount and pedestal type models.

Floor Troughs and Drains



- Heavy duty 14 gauge type 304 stainless steel all-welded construction.
- Designed for assurance of complete drainage.
- Stainless steel drain accommodates up to a 4" diameter pipe and features a removable perforated stainless steel basket.
- Floor drains and floor troughs come with subway-style stainless steel or fiberglass grating.
- Custom lengths available. Consult factory for details.
- Troughs with Wide T-Bar Fiberglass Grating available. ADA-approved for use with the physically handicapped. Wide T-bar width provides a more solid walking area, and prevents objects from fall through. Resistant to corrosion, skid, fire, chipping and cracking.

Anti-Splash

- Patented "anti-splash" design (patent #D519,618 S) assures complete drainage while preventing splash back onto floor.
- Built-in pitch towards drain insures complete drainage.
- Floor troughs come with subway-style stainless steel or fiberglass grating.
- Custom lengths available. Consult factory for details.

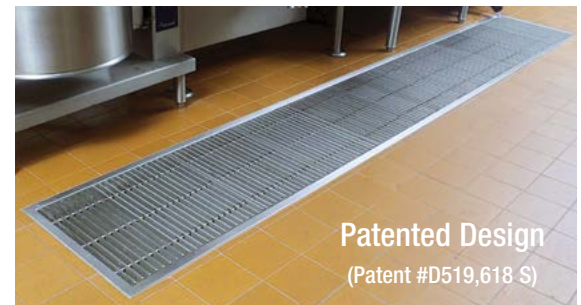

Patented Design
(Patent #D519,618 S)

Stainless Steel Countertops

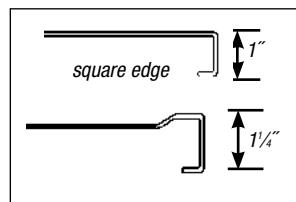
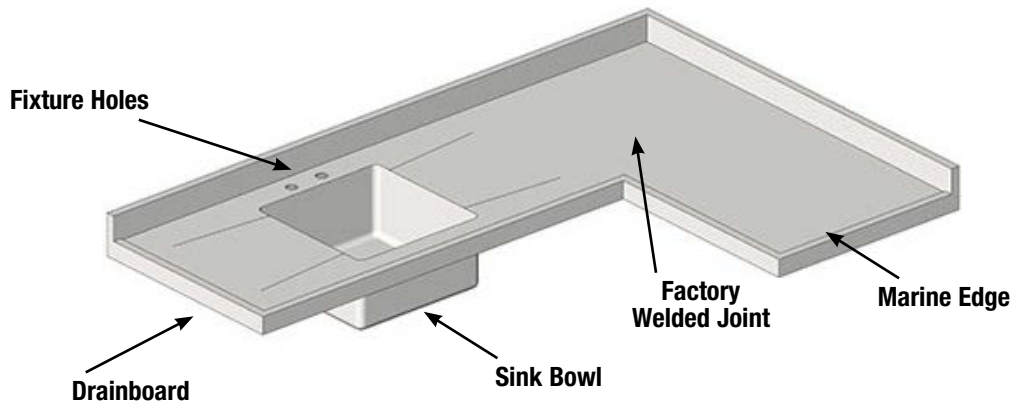
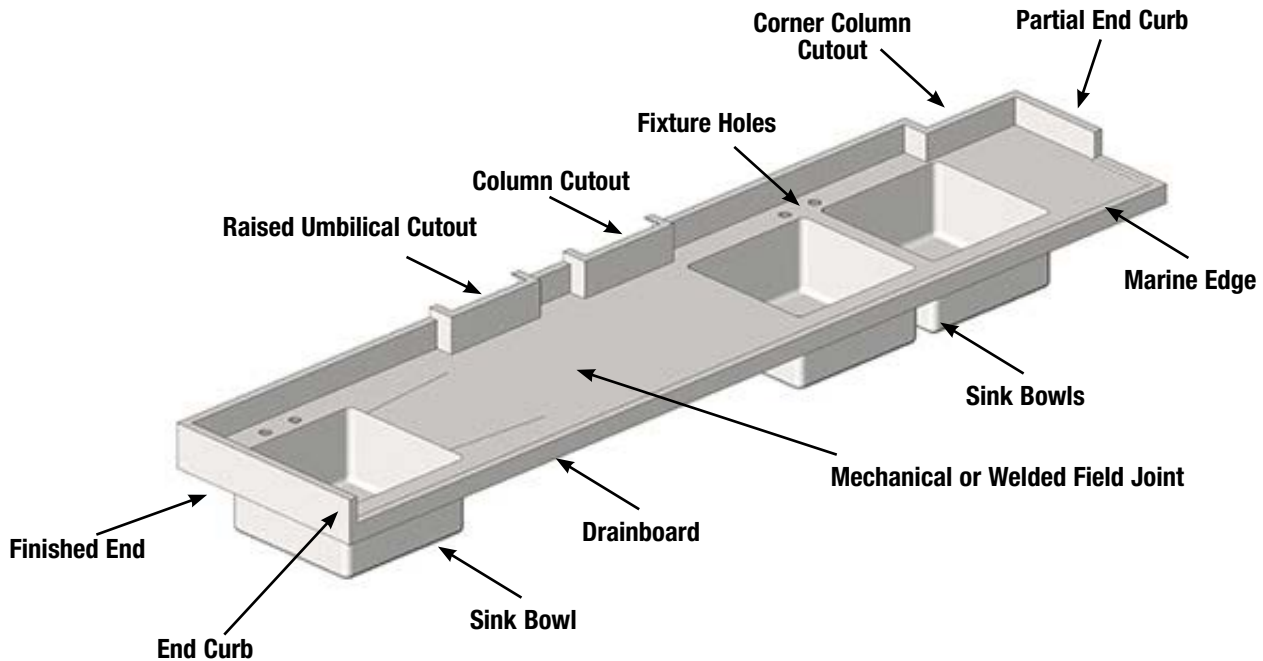

detail 1: edges

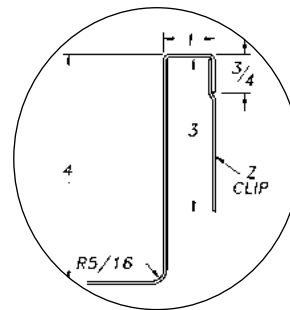

detail 2:
4" backsplash with 1" return and turndown.
Z-clip provided for wall attachment.

- NOTE:**
- Drawings to be submitted for approval prior to fabrication using the latest version of AutoCad software. They will be emailed in Adobe Acrobat format (.pdf) unless specified otherwise. AutoCad files (.dwg) are available upon request.
 - Complete field welding and finishing services are available at additional expense.

Custom Equipment

Manufactured to Your Specifications!

CUSTOM APPLICATIONS COMPRISED OF SPECIALLY FABRICATED, STAINLESS STEEL EQUIPMENT OR PRE-FAB MODULAR COMPONENTS, OR A COMBINATION OF BOTH, WORK THEIR WAY QUICKLY THROUGH A SIMPLE YET SOPHISTICATED DESIGN, APPROVAL AND FABRICATION PROCESS.

EQUIPMENT BUILT TO YOUR EXACT SPECIFICATIONS, PRE-WIRED AND PRE-PLUMBED (IF APPLICABLE), IS SHIPPED WITH SHORTER LEAD TIMES AND AT A LOWER OVERALL COST.

Manufacturing Capabilities:

- Engineering and design assistance.
- Room layouts provided.
- Standard and custom built stainless products.
- Small to large order capacities.
- Designed and built to industry standards.
- Quality controlled throughout process.
- In-house equipment capabilities and standard products provide economical solutions.



Storage Cabinets

Storage Cabinets



double-width unit with baskets



single-width unit with baskets

- Type 304 stainless steel construction.
- 45 pairs of slides on inner panels.
- Hinged doors, with 4" wire-style pulls, available solid or with framed glass.
- Single- and double-width units available.
- 83" height.



Baskets and Trays for Storage Cabinets



#PSST-SB4



#PSST-ST8
shown with dividers

- Cream-colored ABS material.
- Tray stopper keeps basket / tray from falling.
- 23 5/8 x 15 3/4".



Accessories for Baskets and Trays

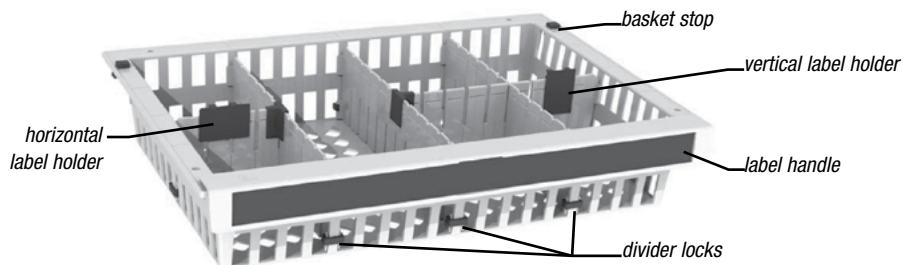

- vertical label holder: can be adhered to top of dividers or front edge of baskets
- horizontal label holder: can be adhered to top of dividers or front edge of baskets
- label handle: color-coded, over 20 colors available
- T-holder for dividers: allows use of custom-length dividers
- basket stop: prevents basket from falling out when pulled

DON'T FORGET ABOUT THE OTHER MARKETS WE SERVE !

Healthcare • Cleanroom • Lab • Material Handling • Plumbing

HOSPITAL SEGMENTS

- SURGICAL SERVICES
- EMERGENCY DEPARTMENT
- PATIENT CARE AREAS
- SAME DAY SERVICES
- LABORATORY
- STERILE PROCESSING & SUPPLY DISTRIBUTION
- PHARMACY
- ENVIRONMENTAL & LINEN SERVICES
- FACILITIES & BIOMEDICAL ENGINEERING

PRODUCTS FOR HEALTHCARE
MAKE THE MOST OF YOUR SPACE

EAGLE
MHC Division
Material Handling, Healthcare & Cleanroom Equipment

Phone: 1-800-441-8440 • F: 302-653-2065 • www.eaglehmc.com

CLEANROOM & LAB Solutions

Pharmaceutical • Biotech • Medical Device • Cleanrooms • Lab • Research

EAGLE
MHC Division
Material Handling, Healthcare & Cleanroom Equipment

Phone: 1-800-441-8440 • F: 302-653-2065 • www.eaglehmc.com

Stainless Steel Inset CASEWORK

Pharmaceutical • Biotech • Medical Device • Cleanrooms • Lab • Research

EAGLE
MHC Division
Material Handling, Healthcare & Cleanroom Equipment

Phone: 1-800-441-8440 • F: 302-653-2065 • www.eaglehmc.com

SHELVING SOLUTIONS

EAGLE GROUP
Profit from the Eagle Advantage!
PHONE: (800) 441-8440 • FAX: 302-653-3000 • FAX: 302-653-2065 • www.eaglegrp.com



Material Handling, Healthcare & Cleanroom Equipment

CLICK ON BROCHURE IMAGE TO DOWNLOAD A COPY

EAGLE GROUP HAND SINKS

GOT SOAP?

EAGLE GROUP
Material Handling, Healthcare & Cleanroom Equipment

PRODUCTS FOR HEALTHCARE
Make the most of your Space.

- Cleanroom Tables
- Floor-Trak® Storage Systems
- Processing Sinks
- Quad-Adjust® Wire Shelving
- QuadPLUS® Polymer Shelving
- Quadtruss® Wire Shelving
- Sterile Wrap Carts
- Stainless Steel Inset Casework

PRODUCTS FOR STERILE PROCESSING

EAGLE
MHC Division
Material Handling, Healthcare & Cleanroom Equipment

Phone: 1-800-441-8440 • F: 302-653-2065 • www.eaglehmc.com

PRODUCTS FOR HEALTHCARE

- Adjustable® Work Surfaces
- Cleanroom Tables
- Countertop Drop-In Sinks
- Floor-Trak® Storage Systems
- Gowning Benches
- Gowning Racks
- Hand Sinks
- Instrument Tables
- Lab Workstations
- Quad-Adjust® Wire Shelving
- QuadPLUS® Polymer Shelving
- Quadtruss® Wire Shelving
- Security Modules
- Security Units
- Stainless Steel Countertops
- Stainless Steel Inset Casework
- Utility Carts
- Vertical Storage Cabinets
- Wall Shelves

PRODUCTS FOR LABORATORIES

EAGLE
MHC Division
Material Handling, Healthcare & Cleanroom Equipment

Phone: 1-800-441-8440 • F: 302-653-2065 • www.eaglehmc.com

PRODUCTS FOR HEALTHCARE

- Adjustable® Work Surfaces
- Angled Shelf Carts
- Countertop Drop-In Sinks
- Floor-Trak® Storage Systems
- Hand Sinks
- Quad-Adjust® Wire Shelving
- QuadPLUS® Polymer Shelving
- Quadtruss® Wire Shelving
- Security Modules
- Security Units
- Stainless Steel Countertops
- Stainless Steel Inset Casework
- Stainless Steel Tables
- Storage Bins
- Utility Carts
- Vertical Storage Cabinets
- Wall Mounted Worktables
- Wall Shelves

PRODUCTS FOR FACILITIES / BIOMEDICAL

EAGLE
MHC Division
Material Handling, Healthcare & Cleanroom Equipment

Phone: 1 800 441 8440 • F: 302-653-2065 • www.eaglehmc.com

