



The EAGLE Advantage for  
**Wire Shelving**



Profit from the Eagle Advantage<sup>®</sup>



# Compare other shelving to EAGLE GROUP's.

See Why EAGLE GROUP is the Smart Choice!

## EAGLE GROUP - 1860 shelf shown

EAGLE GROUP shelves incorporate more serpentine trusses (both perimeter and interior) and mat continuity support wires than any competitive shelf, which translates into more strength per shelf.

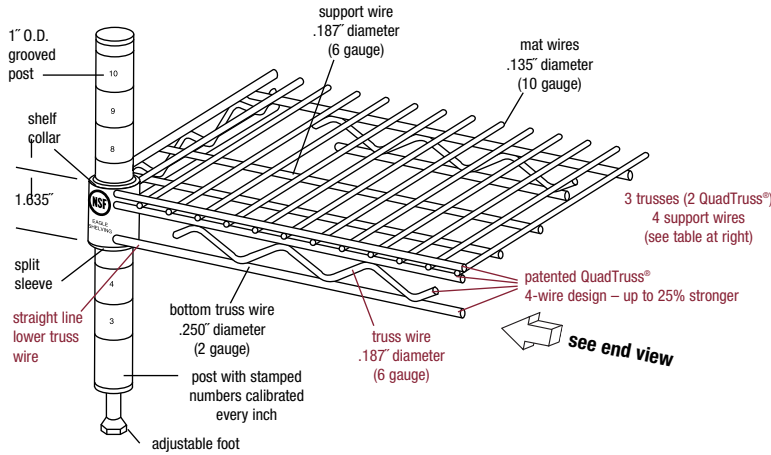

Information in **color** indicates EAGLE advantages — Quality, Value, Reliability.

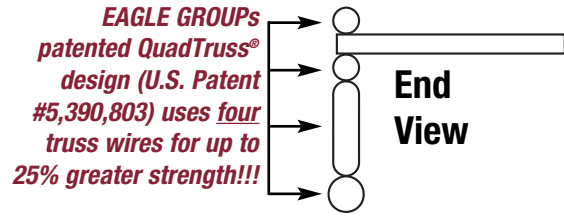

## Metro (and most imports) - 1860 shelf shown

Metro shelving incorporates both perimeter and interior serpentine trusses and mat continuity support wires, but fewer than EAGLE GROUP's shelving.

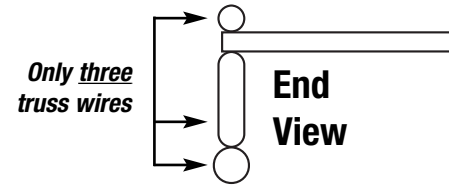
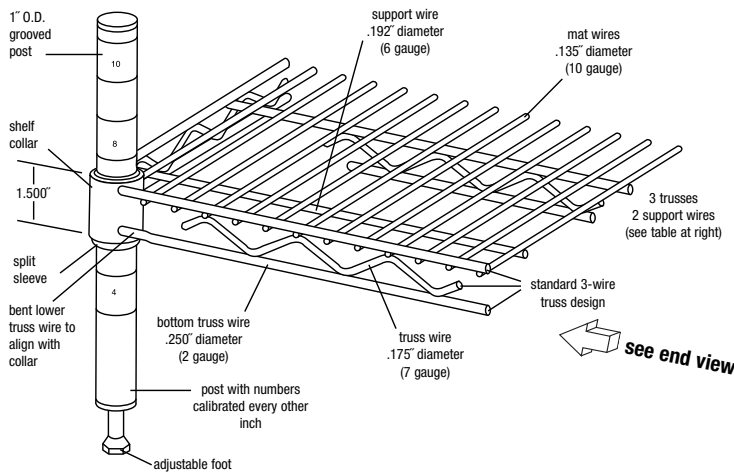

## ISS - 1860 shelf shown

ISS shelving uses no perimeter serpentine trusses, relying on perimeter line wires connected by waterfall mat wires for support with serpentine trusses - used interior only.

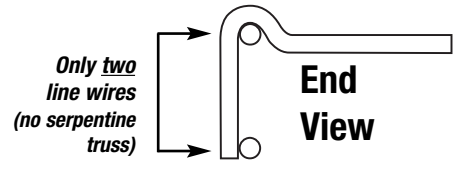
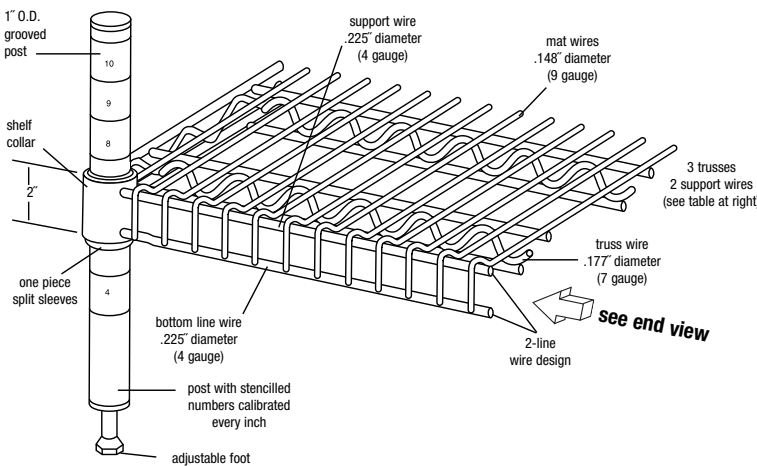

# Compare other shelving to EAGLE GROUP's.

See Why  
EAGLE GROUP  
is the Smart  
Choice!

## US vs. THEM

### EAGLE GROUP

Compare and note the strength advantages provided by EAGLE GROUP versus competitor shelving. As much as 80% more perimeter and interior trusses incorporated into EAGLE GROUP shelving makes EAGLE GROUP shelves 25% stronger than Metro shelving.

width*	side trusses	center trusses	mat continuity support wires	end view	total trusses	length	total # of trusses & mat support wires	EAGLE truss & support wires vs. competitor
14"	2	0	5		2	all	7	<b>40% MORE</b>
18"	2/2	0/1	7/6		2/3	24"-72"	9/9	<b>80% MORE</b>
21"	2/2	0/1	5/4		2/3	24"-72"	7/7	<b>40% MORE</b>
24"	2	1	6		3	24"-66"	9	<b>29% MORE</b>
24"	2	2	5		4	72"	9	<b>29% MORE</b>
30"	2	4	4		6	36"-72"	10	<b>11% MORE</b>

\* We also offer 36" wide

### Metro (and most imports)

Metro's shelf has as much as 80% less perimeter and interior trusses included in its systems and an average of 38% less support than EAGLE GROUP shelves.

width	side trusses	center trusses	mat continuity support wires	end view	total trusses	length	total # of trusses & mat support wires	Metro truss & support wires vs. EAGLE
14"	2	0	3		2	all	4	<b>40% LESS</b>
18"	2	0/1	3/2		2/3	36"-72"	5/5	<b>80% LESS</b>
21"	2	1	2		3	36"-72"	5	<b>40% LESS</b>
24"	2	1	4		3	24"-54"	7	<b>29% LESS</b>
24"	2	1/2	4/3		3/4	60"-72"	7/7	<b>29% LESS</b>
30"	2	3	4		5	36"-72"	9	<b>11% LESS</b>

### ISS

This competitor's shelf has as much as 80% less perimeter and interior trusses included in its systems and an average of 68% less support than EAGLE GROUP shelves.

width	side trusses	center trusses	mat continuity support wires	end view	total trusses	length	total # of trusses & mat support wires	ISS truss & support wires vs. EAGLE
14"	0	2	2		2	all	4	<b>75% LESS</b>
18"	0	3	2		3	48"-72"	5	<b>80% LESS</b>
21"	0	3	2		3	36"-72"	5	<b>40% LESS</b>
24"	0	3	2		3	24"-72"	5	<b>80% LESS</b>
30"	0	4	2		4	36"-72"	6	<b>67% LESS</b>

An independent inspection bureau and testing laboratory conducted a test to measure the amount of deflection when weight is loaded onto a wire shelf. The result: With its patented QuadTruss® design, EAGLE GROUP has the strongest shelf in the industry! The chart below shows the results!

shelf size (in inches):	18" x 48"				18" x 60"				24" x 60"				
static load (in pounds):	600	800	1000	1200	600	800	1000	1200	600	800	1000	1200	
<b>EAGLE</b>	<b>0.204"</b>	<b>0.259"</b>	<b>0.343"</b>	<b>0.415"</b>	<b>0.269"</b>	<b>0.340"</b>	<b>0.479"</b>	<b>0.597"</b>	<b>0.245"</b>	<b>0.315"</b>	<b>0.441"</b>	<b>0.548"</b>	
deflection (in inches):	ISS	0.211"	0.260"	0.360"	0.430"	0.339"	0.429"	0.615"	0.741"	0.324"	0.414"	0.614"	0.778"
	Metro	0.278"	0.349"	0.476"	0.575"	0.334"	0.423"	0.620"	0.776"	0.354"	0.444"	0.612"	0.735"

Tested by West Penn Laboratories, Turtle Creek, PA.

## Compare side-by-side!

### Warranty comparison of equivalent finishes

EAGLE GROUP		Metro		ISS	
Finish	Warranty	Finish	Warranty	Finish	Warranty
chrome	1 year	chrome	1 year	chrome	1 year
EAGLEbrite®	3 years	Erecta Brite	1 year	Plating Plus	1 year
VALU-MASTER® gray epoxy	5 years	no equivalent	—	no equivalent	—
Valu-Gard® green epoxy	5 years	no equivalent	—	no equivalent	—
EAGLEgard® green epoxy	12 years	MetroSeal III	12 years	SuperSeal/GoldBond	15 years/15 years
stainless steel	15 years	stainless steel	10 years	stainless steel	12 years

## Shelf and post finishes:

- EAGLE GROUP's shelving and posts are offered in five finishes (see chart at right for details):
- Posts are numbered in 1" increments to ensure fast and level assembly, and are available in a wide variety of lengths from 7" to 86". EAGLE GROUP was the first in the industry to incorporate imprinted numbers on posts.
- Shelf strength is increased by top surface mat wires being 10% larger than industry standards. In addition, the mat on an EAGLE GROUP shelf rests on top of three supporting truss wires, adding significant strength and distributing the entire load without stress and strain on the welds.
- Open-wire construction promotes higher visibility, allows light to pass through the shelves, permits greater air circulation which helps reduce moisture and dust build-up, and increases the effectiveness of fire-suppression systems.
- Tapered, high-temperature-resistant high-impact ABS plastic split sleeves create a positive lock that becomes stronger as the load increases.
- Leveling feet are provided to help compensate for uneven floor surfaces. Each adjustable foot has a tapered shoulder for strength and cleanliness.

## Shelving Accessories

A number of options are available for EAGLE GROUP shelving. For more information about options and accessories, consult our Price List or check out our web site at [www.eaglegrp.com](http://www.eaglegrp.com).

- Dividers & Ledges
- Foot Plates & Glides
- Casters
- Slide Systems
- Label Holders
- Rods & Tabs, and more...

<p><b>Stainless Steel finish — OUR BEST</b></p> <ul style="list-style-type: none"> <li>• <i>Stainless steel</i></li> </ul> <p>NSF-listed for all environments. Type 304 stainless steel.  <b>15-Year Limited Warranty</b>            (NOTE: Stainless steel shelving is electropolished)</p>	
<p><b>EAGLEgard® hybrid epoxy</b></p> <ul style="list-style-type: none"> <li>• <i>Zinc chloride</i></li> <li>• <i>Clear chromate</i></li> <li>• <i>MasterSeal® sealer</i></li> <li>• <i>Blue green hybrid epoxy with MICROGARD®</i></li> </ul> <p>NSF-listed for all environments. Zinc chloride plating followed by clear chromate plating with MasterSeal® sealer and a hybrid epoxy final coat.  <b>12-Year Limited Warranty</b></p>	
<p><b>VALU-MASTER®/Valu-Gard® epoxy</b></p> <ul style="list-style-type: none"> <li>• <i>Phosphate conversion coating</i></li> <li>• <i>MasterSeal® sealer</i></li> <li>• <i>Pewter gray epoxy or green epoxy</i></li> </ul> <p>NSF-listed for wet or dry storage environments. Phosphate conversion coating followed by metallic gray or green epoxy coating.  <b>5-Year Limited Warranty</b></p>	
<p><b>Chrome</b></p> <ul style="list-style-type: none"> <li>• <i>Bright nickel</i></li> <li>• <i>Chrome</i></li> <li>• <i>Air-dry lacquer</i></li> </ul> <p>NSF-listed for dry storage environments. Bright nickel plating followed by chrome plating.  <b>1-Year Limited Warranty</b>            (NOTE: Optional clear hybrid epoxy, NSF-listed for all environments, is available.)</p>	
<p><b>EAGLEbrite® zinc</b></p> <ul style="list-style-type: none"> <li>• <i>Zinc chloride</i></li> <li>• <i>Clear chromate</i></li> <li>• <i>MasterSeal® sealer</i></li> <li>• <i>Air-dry lacquer</i></li> </ul> <p>NSF-listed for dry storage environments. Bright zinc chloride plating followed by clear chromate plating with MasterSeal® sealer for improved rust protection.  <b>3-Year Limited Warranty</b>            (NOTE: Wire shelves feature MasterSeal® sealer. Posts feature clear hybrid epoxy, NSF-listed for all environments.)</p>	

MICROGARD® is an antimicrobial agent which contains built-in protection to retard the growth of a broad range of bacteria, mold and mildew on shelf surface that causes stains, odors and degradation. Standard on all EAGLEgard®.



Quality

Value

Reliability

# Profit from the EAGLE Advantage®

Corporate Headquarters • 100 Industrial Boulevard  
Clayton, DE 19938-8903  
• Phone: (302) 653-3000

Foodservice, Material Handling, and SpecFAB® Divisions • Phone: (800) 441-8440  
• Fax: (302) 653-2065

[www.eaglegrp.com](http://www.eaglegrp.com)



© 2021 EAGLE GROUP. EAGLEbrite®, EAGLEgard®, MasterSeal®, MICROGARD®, QuadTruss®, and Valu-Master® are registered trademarks of EAGLE GROUP. Although every attempt has been made to ensure the accuracy of the data in this publication, we cannot be responsible for printing or typographical errors or omissions. Due to an ongoing product improvement program, specifications, dimensions and prices are subject to change without notice.