



INSTALLATION INSTRUCTIONS

CAUTION

INSPECT CONTENTS IMMEDIATELY AND FILE CLAIM WITH DELIVERING CARRIER FOR ANY DAMAGE. **SAVE YOUR BOX AND ALL PACKING MATERIALS.** YOU ARE RESPONSIBLE FOR DAMAGE TO YOUR UNIT IF RETURNED IMPROPERLY PACKED.

Tools Needed:

- Level
- Ratchet with 1/4" Socket

Thank you for your purchase. Before assembly, read these instructions carefully.

After reading, be sure to store this instruction in a safe place, should it be needed for future reference.

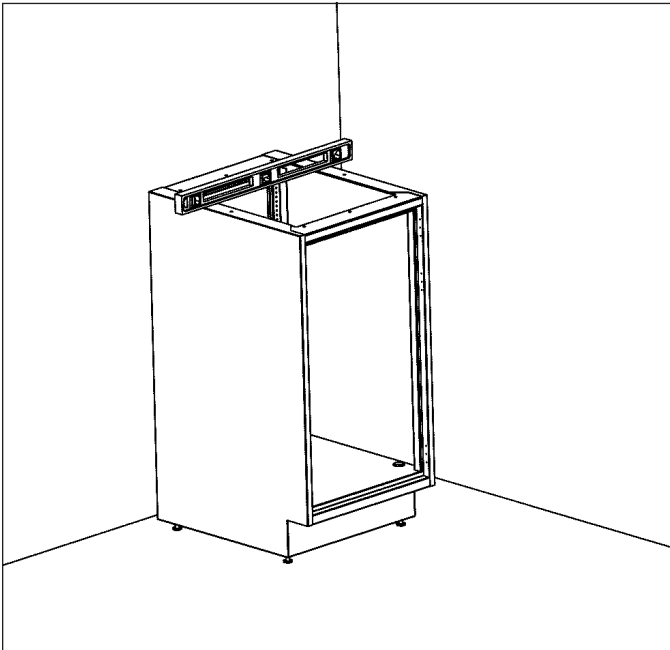

Step 1:

Place cabinet on floor at desired location. Check to see if the cabinet is level front-to-back and side-to-side. If cabinet is not level, proceed to next step. If cabinet is level, skip to **Step 5** on back page.

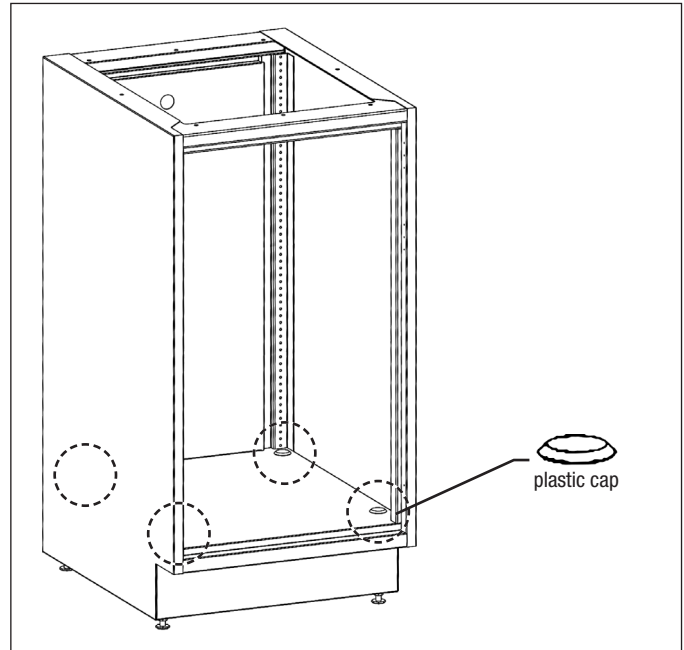

Step 2:

Once against the wall, remove the four plastic caps located at each corner on the bottom panel inside cabinet.

(continued on back page) 

EG10112 Rev 03/24

Casework Base Cabinets

INSTALLATION INSTRUCTIONS

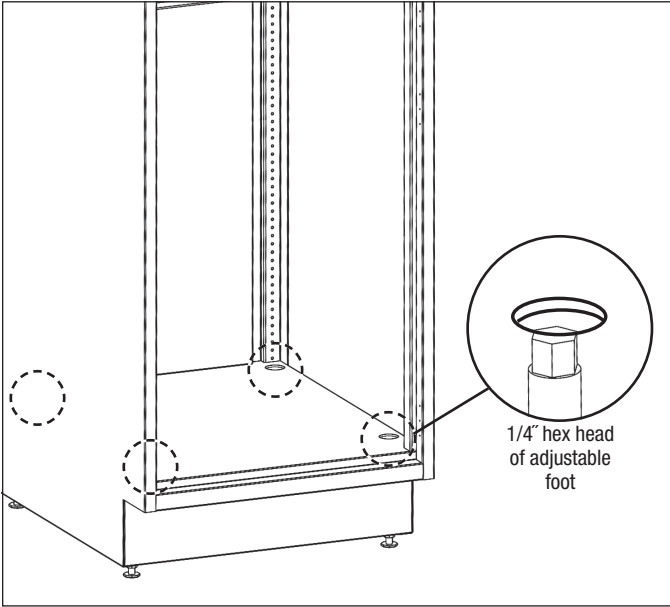

Step 3:

At each leg, using a 1/4" socket, turn hex head bolt to adjust height of foot.

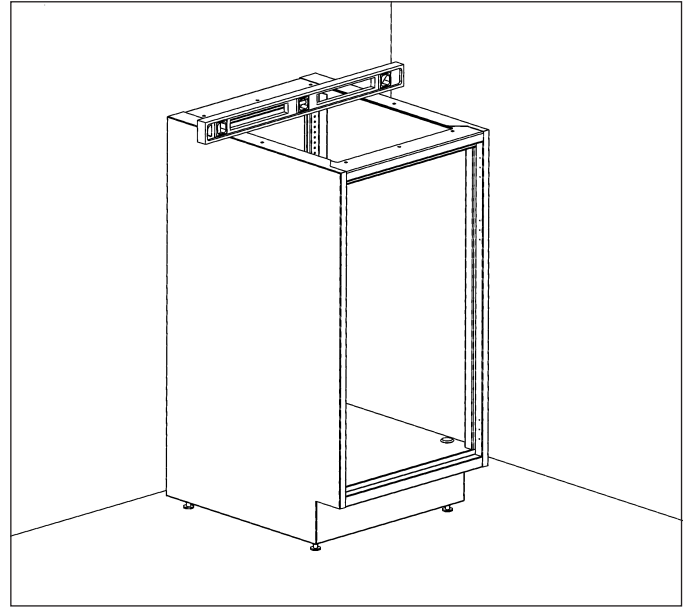

Step 4:

Adjust feet until cabinet is level front-to-back and side-to-side. When adjustments are completed, return plastic caps.

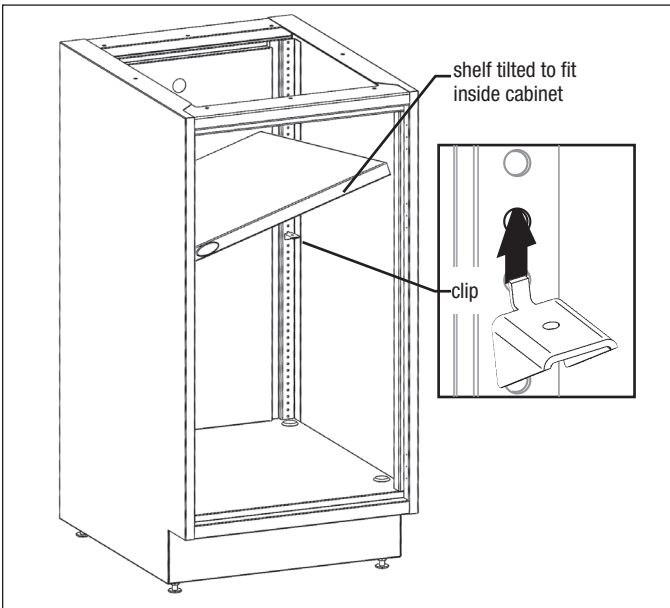

Step 5:

To install shelf, tilt shelf to fit inside cabinet. Install shelf clips at desired height, and place shelf on top of clips.

Installation is complete.

(End)

Removable back panel:

Back panel is easily removable for access behind the cabinet. Shelf must be removed first.

