



## INSTALLATION INSTRUCTIONS

### CAUTION

INSPECT CONTENTS IMMEDIATELY AND FILE CLAIM WITH DELIVERING CARRIER FOR ANY DAMAGE. **SAVE YOUR BOX AND ALL PACKING MATERIALS.** YOU ARE RESPONSIBLE FOR DAMAGE TO YOUR UNIT IF RETURNED IMPROPERLY PACKED.

Thank you for your purchase. Before assembly, read this instruction manual carefully. After reading, be sure to store this instruction in a safe place, should it be needed for future reference.

#### Tools Needed:

- Level
- Drill and 1/8" drill bit
- Tape measure
- Screwdriver or driver bit for hardware\*

#### Before assembly:

- Determine the area where the cabinet will be mounted.
- Verify that you have sufficient structural support in the wall to be able to properly hold the cabinet and its contents.
- Depending on the wall surface, use the appropriate wall mounting hardware\*.

**IMPORTANT NOTE:** Depending on construction of wall, wall cabinets should be attached to wall studs, in-wall grounds (wall backing) of plywood or sheet metal, or solid part of brick or concrete wall with appropriate fasteners. Failure to use appropriate fasteners could result in collapse and personal injury. Eagle Group cannot be held responsible for failure of the device or any other devices due to improper installation. Also, it is your responsibility to make certain the mounting surface and method of mounting are suitable to support the anticipated weight which will be placed in this unit.

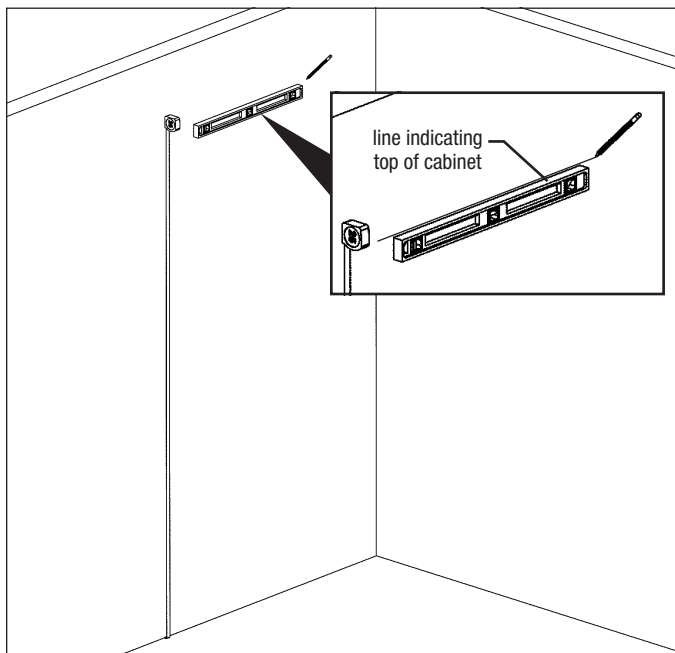

#### Step 1:

Measure and mark desired height of overhead cabinet. Use a level to extend line.

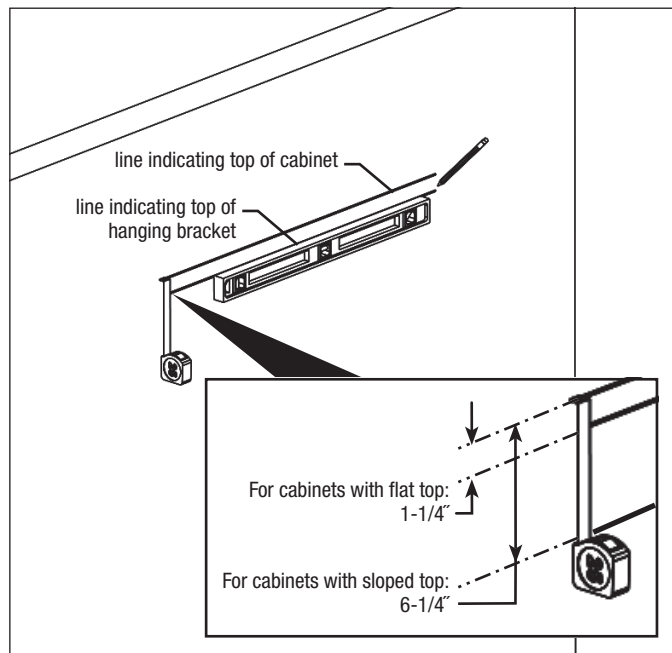

#### Step 2:

Measure either 1-1/4" or 6-1/4" lower than the first line, depending on whether your cabinet has a flat top or a sloped top (see inset above). Mark for top of hanging bracket. Extend line using a level.

\* Wall mounting hardware not included

(continued on back page)

EG10111 Rev 03/24



- 100 Industrial Boulevard, Clayton, Delaware 19938-8903 U.S.A.
- Phone: 302/653-3000 • 800/441-8440 • Fax: 302/653-2065
- www.eaglegrp.com • www.eaglemhc.com

# Casework Wall Cabinets

## INSTALLATION INSTRUCTIONS

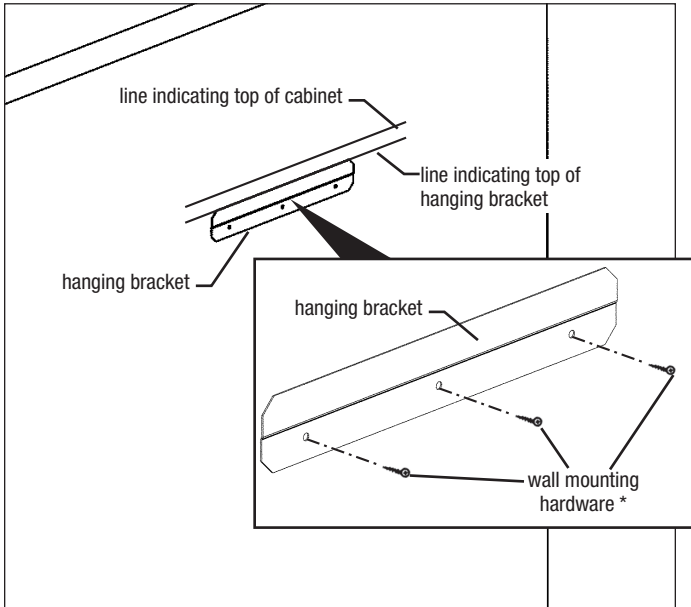

### Step 3:

Mount hanging bracket to wall\*.

**CAUTION:** Installer must secure bracket to at least one wall stud, and use anchors\* on any screws\* that cannot be secured to studs.

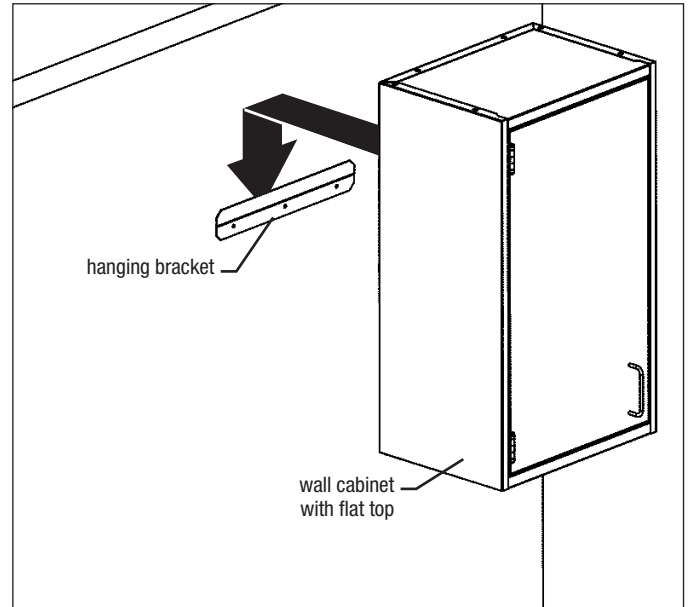

### Step 4:

Hook the back of cabinet onto the wall mounted hanging bracket. Adjust and level cabinet to desired location.

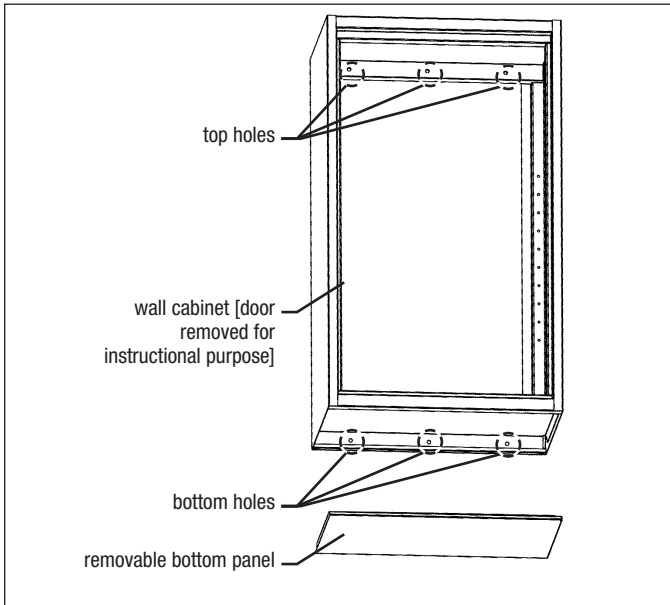

### Step 5:

Attach cabinet to wall\*, using the top and bottom holes. Top holes are visible. To access the bottom holes, set aside removable bottom panel. Replace panel after securing cabinet to wall.

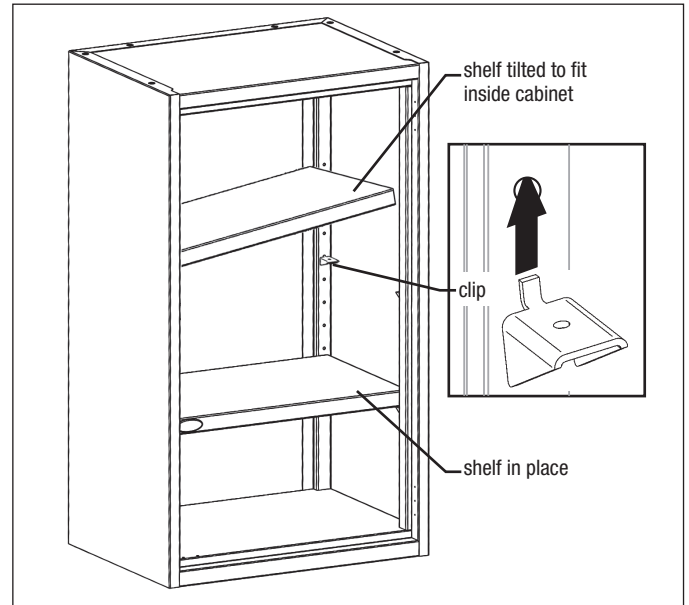

### Step 6:

Tilt shelf to fit into cabinet. Install shelf clips at desired height, and place shelf on top of clips.

Installation is complete.



\* Wall mounting hardware not included



- 100 Industrial Boulevard, Clayton, Delaware 19938-8903 U.S.A.
- Phone: 302/653-3000 • 800/441-8440 • Fax: 302/653-2065
- [www.eaglegrp.com](http://www.eaglegrp.com) • [www.eaglehmc.com](http://www.eaglehmc.com)