

Roll Bag Holders

ASSEMBLY INSTRUCTIONS

CAUTION

INSPECT CONTENTS IMMEDIATELY AND FILE CLAIM WITH DELIVERING CARRIER FOR ANY DAMAGE. **SAVE YOUR BOX AND ALL PACKING MATERIALS.** YOU ARE RESPONSIBLE FOR DAMAGE TO YOUR UNIT IF RETURNED IMPROPERLY PACKED.

Parts List

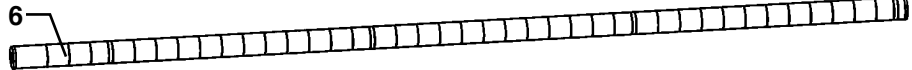
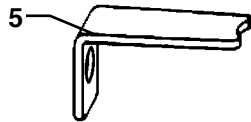
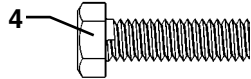
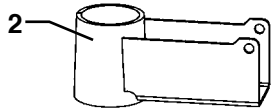
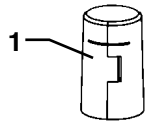

Item #	qty	description
1	1	bag of four split sleeves
2	2	hanger bracket
3	2	hair pin cotter
4	2	hex-head bolt
5	2	bar clip
6	1	roll tube

Step 1 - Snap split sleeves to rear posts of unit.

Attach split sleeves where roll holder is to be located. The thicker part of the split sleeves goes toward the bottom.

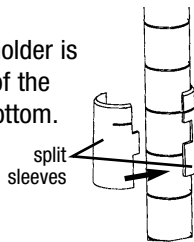

Step 2 - Attach hanger brackets to split sleeves.

With hanger brackets facing each other, slide each bracket down posts and onto split sleeves.

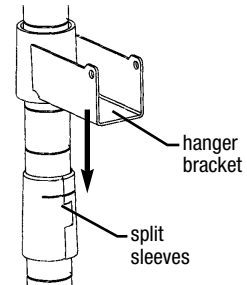

Step 3 - Attach clips to roll tube.

IMPORTANT: Test-fit and place rolls onto roll tube **BEFORE** attaching clips.

Use 5/8" wrench or socket to tighten bolts.

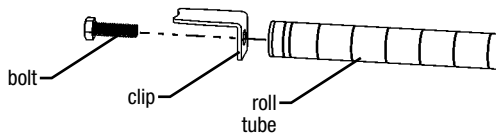

Step 4 - Install roll tube assembly to hanger brackets.

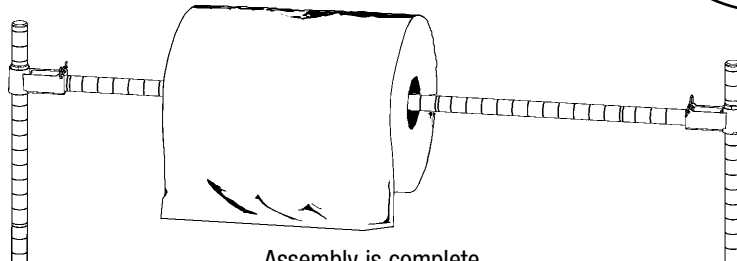
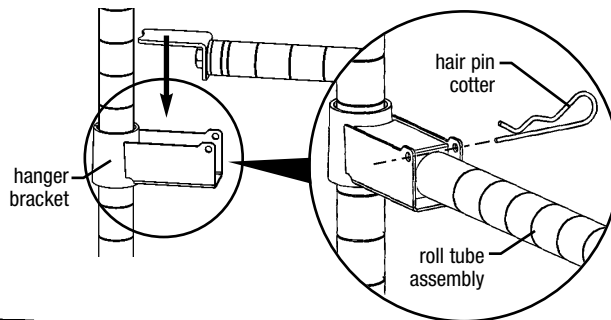

Assembly is complete.

(End)

EG10092 Revised 10/23