

Gowning Benches with Undershef

—36", 48", and 60" in length

ASSEMBLY INSTRUCTIONS

If your gowning rack is 72"-long, refer to reverse page.

CAUTION

INSPECT CONTENTS IMMEDIATELY AND FILE CLAIM WITH DELIVERING CARRIER FOR ANY DAMAGE. **SAVE YOUR BOX AND ALL PACKING MATERIALS.** YOU ARE RESPONSIBLE FOR DAMAGE TO YOUR UNIT IF RETURNED IMPROPERLY PACKED.

Thank you for your purchase. These instructions are for how to assemble a Gowning Bench with solid or perforated seat and wire undershef. Before assembly, read this instruction sheet carefully to ensure correct use. After assembly, store in a safe place, should it be needed for future reference.

Step 1 - Attach split sleeves (for undershef) to lowest groove on posts.

- The wider part of the taper goes toward the bottom.
- Make sure rib on split sleeve is seated into a groove on the post.

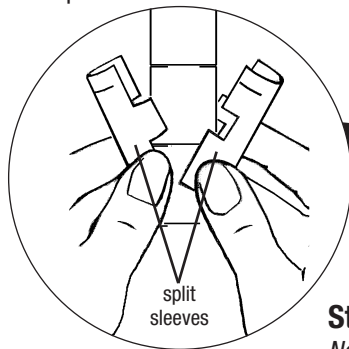

Step 2 - Mount undershef.

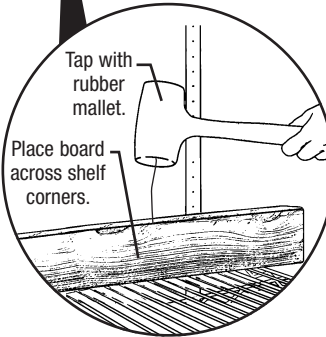
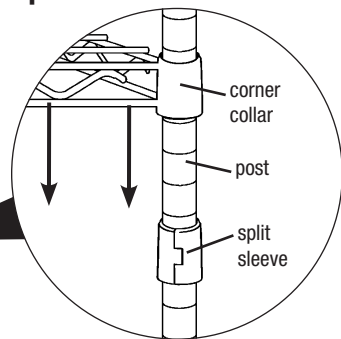
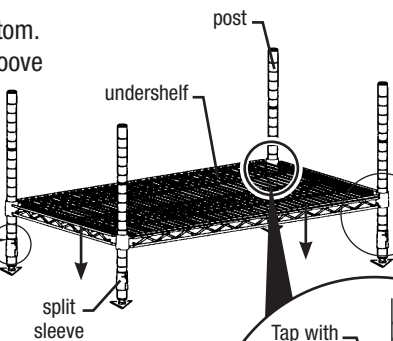

Step 3: Secure undershef.

Note: Do NOT hammer directly on wire or corner.

Please note: If additional undershef was ordered, install now by repeating Steps 1 through 3, attaching split sleeves onto middle of posts. Otherwise, proceed to Step 4 below.

Step 4: Attach seat to posts.

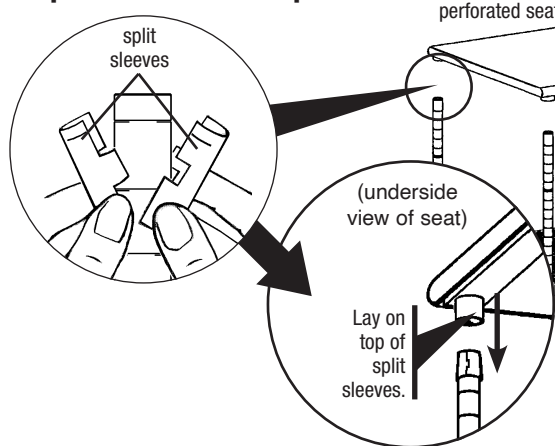

Assembly is complete.



Gowning Benches with Undershef

- 72" in length

ASSEMBLY INSTRUCTIONS

Please note:

72"-long gowning racks come with SIX posts and TWO wire undershelves.
The enclosed S-hooks will therefore be required to complete assembly.

Step 1 - Attach split sleeves (for first undershef) to lowest groove on four posts.

- The wider part of the taper goes toward the bottom.
- Make sure rib on split sleeve is seated into a groove on the post.

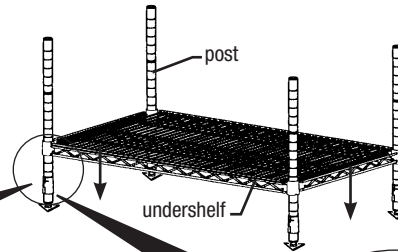
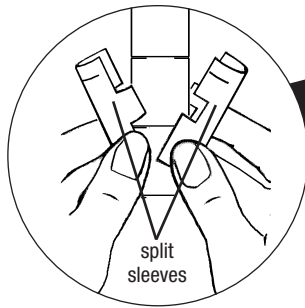

Step 2 - Mount first undershef.

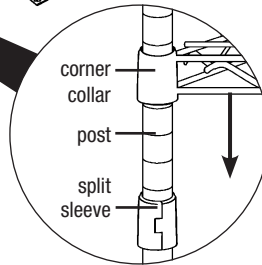

Step 3 - By repeating Steps 1 and 2, attach second undershef to the two remaining posts.

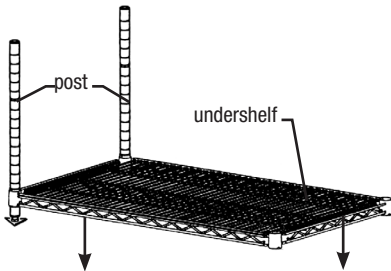

Step 4 - Connect second assembly to first assembly.

NOTE: Place each "S" hook near a post as closely as possible.

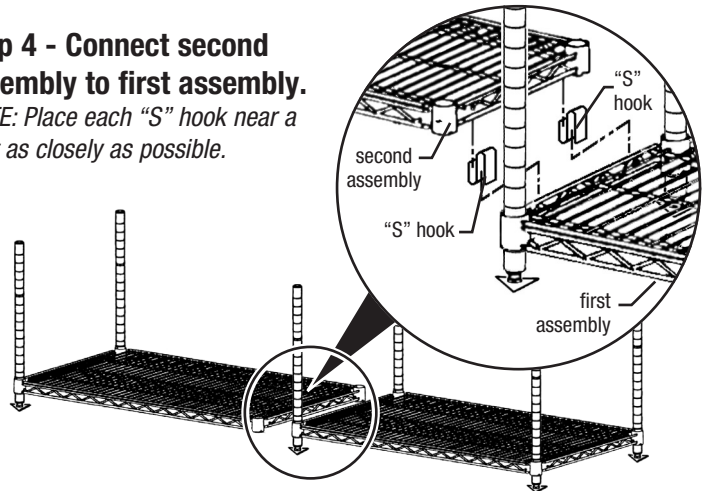

Step 5: Secure undershelves.

Note: Do NOT hammer directly on wire or corner.

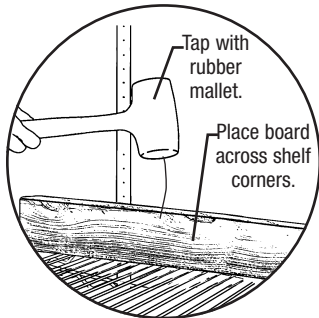

Please note:
If additional undershelves were ordered, install now by repeating Steps 1 through 5, attaching split sleeves onto middle of posts. Otherwise, proceed to Step 6.

Step 6: Attach seat to posts.

Refer to Step 4 on reverse page.

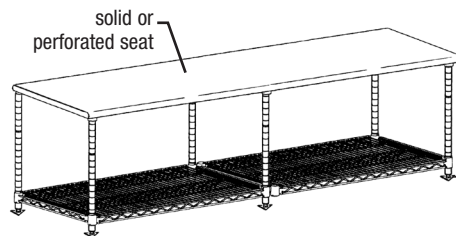

Step 7: Secure feet to the floor.

Hardware not included.

Assembly is complete.

