

Tote Box Stops

INSTALLATION INSTRUCTIONS

CAUTION

INSPECT CONTENTS IMMEDIATELY AND FILE CLAIM WITH DELIVERING CARRIER FOR ANY DAMAGE. **SAVE YOUR BOX AND ALL PACKING MATERIALS.** YOU ARE RESPONSIBLE FOR DAMAGE TO YOUR UNIT IF RETURNED IMPROPERLY PACKED.

NOTE: Eagle tote box carts include spring stop-clips to keep totes from sliding out during transport. These should be located on opposite ends of each pair of slides. It is easiest to install these on the **LEFT HAND** slide as you are looking at the cart.

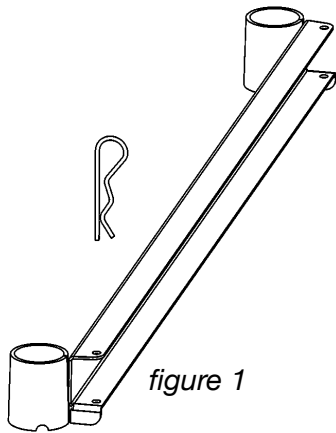

1) Position clip so straight wire side is on the top of bottom flange and wire end is below. See *figure 1*.

2) Spreading the wires with a slight counterclockwise motion, push the end to the hole in bottom flange.

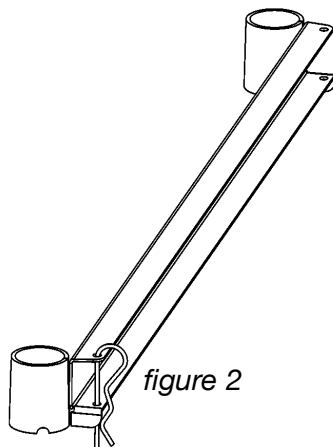

3) To prevent totes from sliding out, install the hook into the hole of top flange and push downward to secure. Slot will capture shank of hook when properly installed. See *figure 2*.