

Gowning Racks with Hanger Tube

ASSEMBLY INSTRUCTIONS

CAUTION

INSPECT CONTENTS IMMEDIATELY AND FILE CLAIM WITH DELIVERING CARRIER FOR ANY DAMAGE.
SAVE YOUR BOX AND ALL PACKING MATERIALS.
YOU ARE RESPONSIBLE FOR DAMAGE TO YOUR UNIT IF RETURNED IMPROPERLY PACKED.

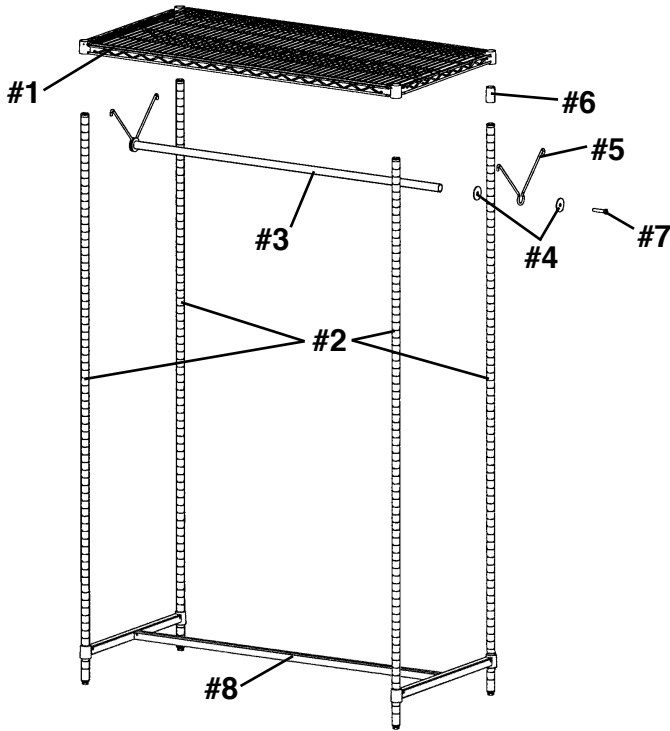

Parts List

#	qty	part #	description
#1	1	*	Wire Shelf
#2	4	**	Post
#3	1	203904	Post for Hanger
#4	4	204112	Washer for Hanger
#5	2	203902	Wire Hanger Frame
#6	8	PLASTIC SPLIT SLEEVES	Split Sleeve
#7	2	A201680	Bolt for Hanger
#8	1	***	H-frame

* Width and length of shelf determine part number.
** Type of finish determines part number.
*** Width and length of H-frame determine part number.

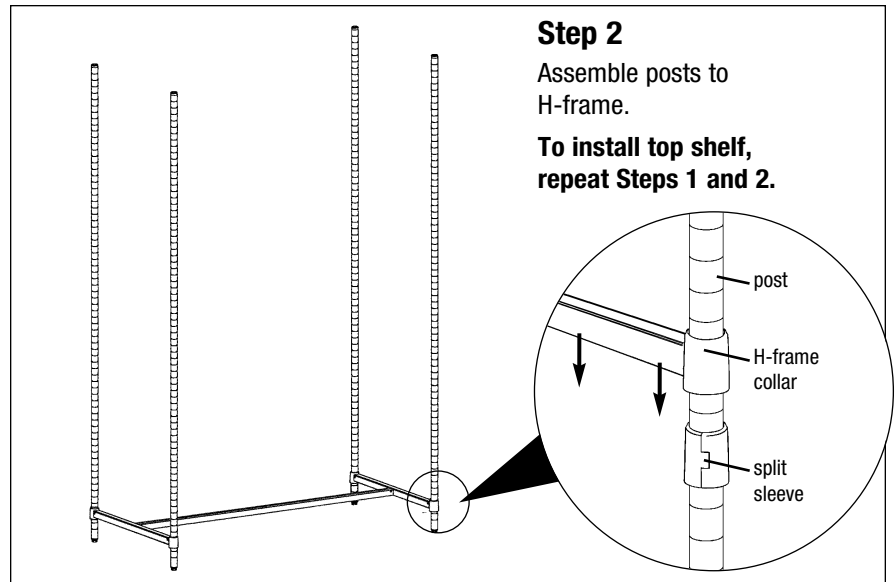
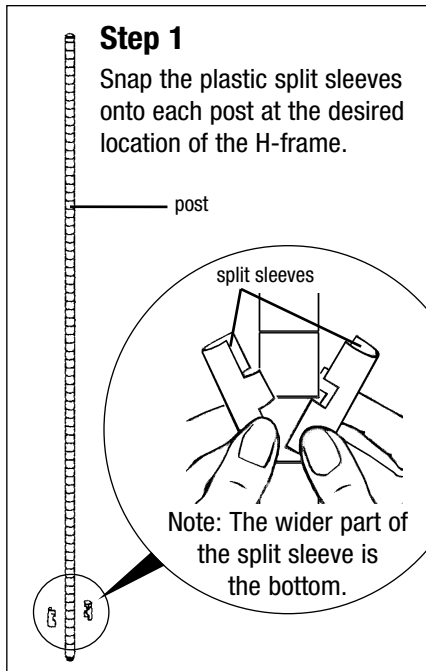

(continued on back page)

EG10003 Revised 07/23

Gowning Racks with Hanger Tube

ASSEMBLY INSTRUCTIONS

Step 3

Assemble hanger.

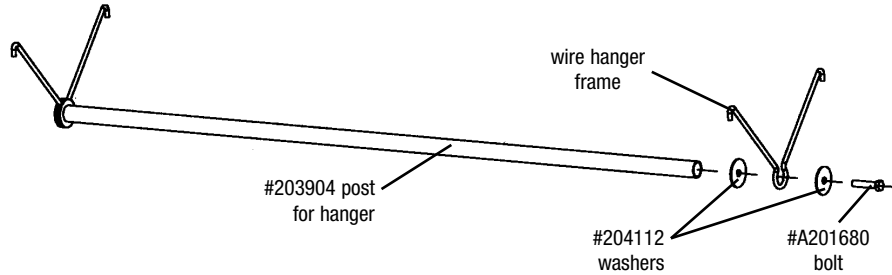

Step 4

Attach hanger assembly to underside of top shelf.

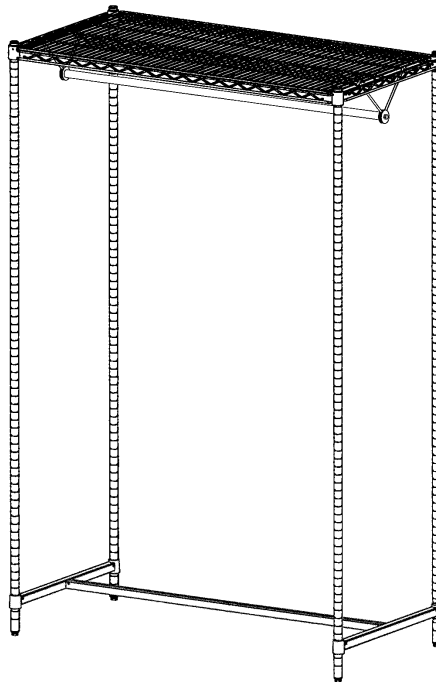
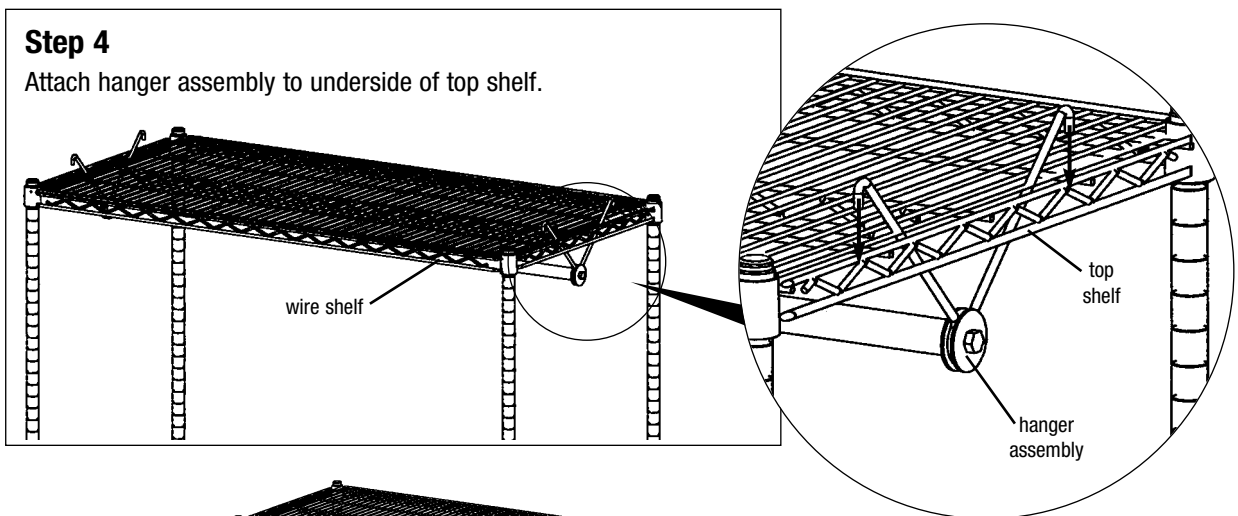

Assembly is complete.

(End)