

Gowning Racks with Hanger Slots

ASSEMBLY INSTRUCTIONS

CAUTION

INSPECT CONTENTS IMMEDIATELY AND FILE CLAIM WITH DELIVERING CARRIER FOR ANY DAMAGE.

SAVE YOUR BOX AND ALL PACKING MATERIALS.

YOU ARE RESPONSIBLE FOR DAMAGE TO YOUR UNIT IF RETURNED IMPROPERLY PACKED.

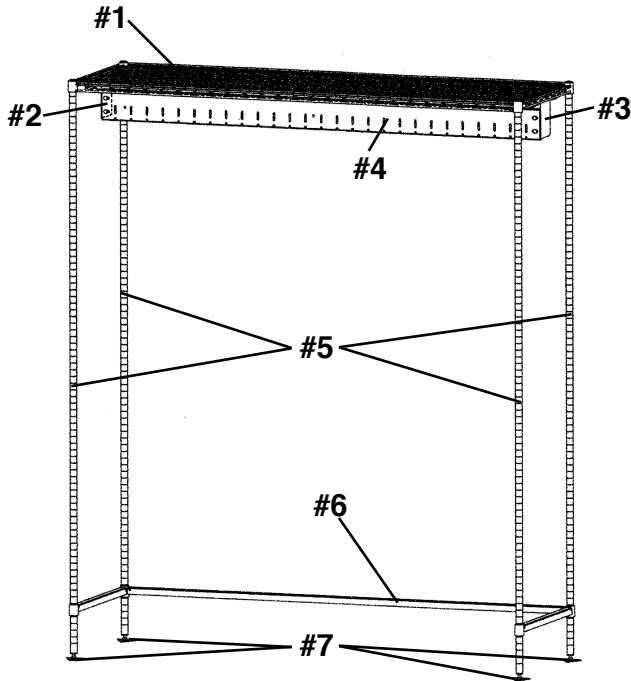

Parts List

#	qty	part #	description
#1	1	*	Wire Shelf
#2	1	*	Left-hand bracket
#3	1	*	Right-hand bracket
#4	1	*	Hanger bar
#5	4	*	Post
#6	1	*	3-sided channel frame
#7	4	*	Triangular foot
#8	2	A200816	Bag of 4 split sleeves

* Size and/or finish determines part number.

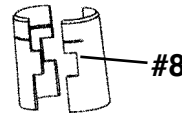

Step 1 - Assemble foot to post.

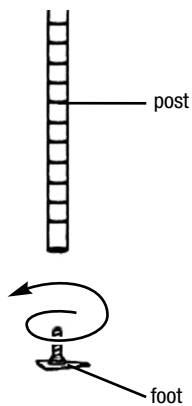

Step 2 - Attach split sleeves to #5 groove on each post.

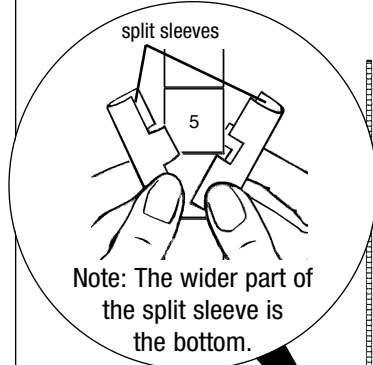

Step 3 - Assemble C-frame to posts.

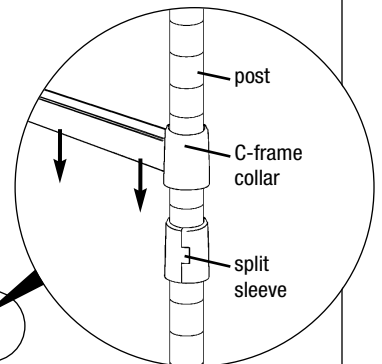

(continued on back page)

Gowning Racks with Hanger Slots

ASSEMBLY INSTRUCTIONS

Step 4 - Attach top shelf to topmost groove on posts.

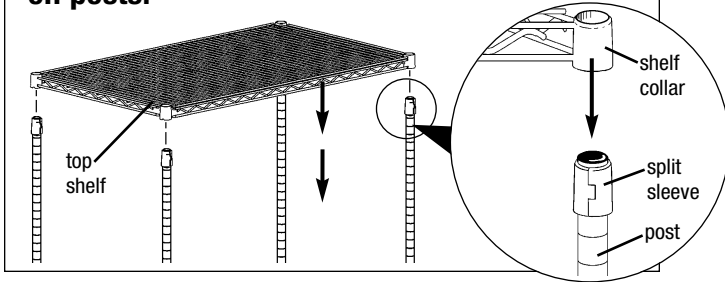

Step 5 - Attach side brackets to top shelf.

On each end, slide bracket up through the underside of the top shelf and hook onto wire truss as shown.

Note: Make sure the louvered holes on both brackets are facing forward (opposite the long side of the 3-sided channel frame).

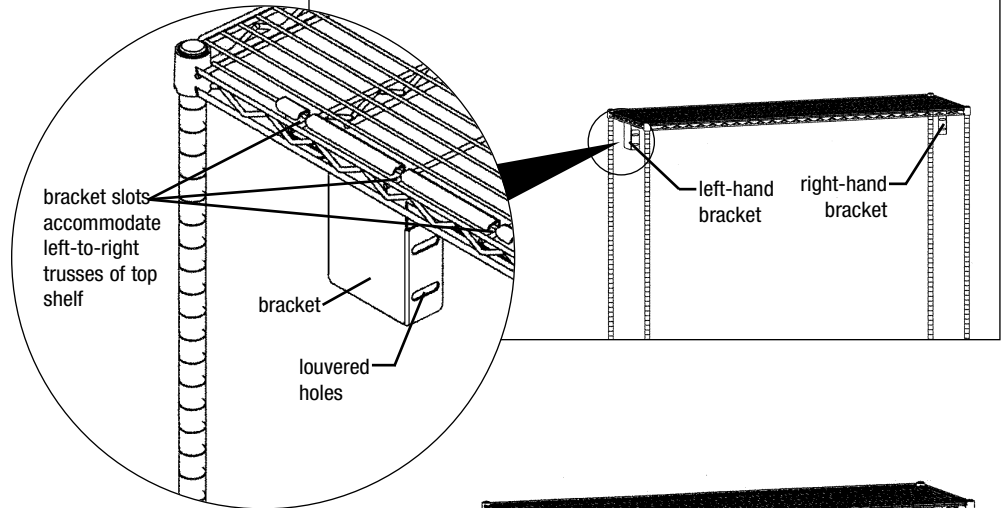

Step 6 - Bolt hanger bar to bracket.

Note: Make sure the hanger slots face downward.

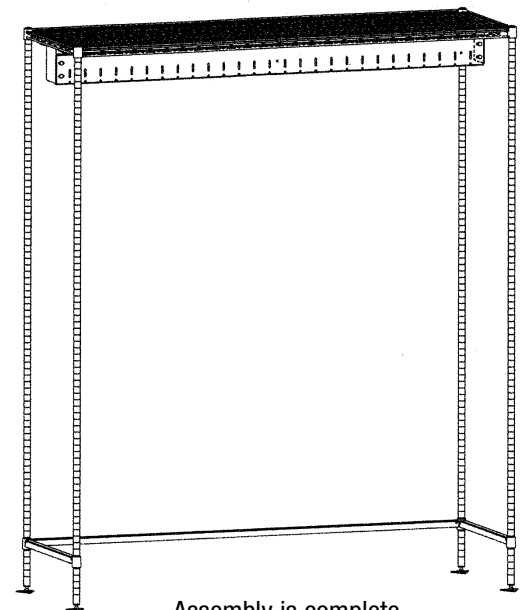
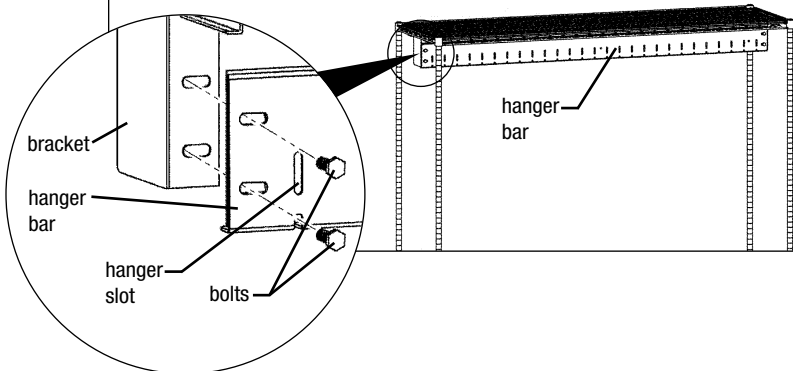

Assembly is complete.