



Profit from the Eagle Advantage®

Specification Sheet

Short Form Specifications

Eagle worktables, Spec-Master® series, model _____ . Top constructed of 14 gauge 300 series stainless steel with 1½" roll on front, 1½" rear upturn, and sides turned down 90°. Open front with 1¼" O.D. stainless steel tubular crossbracing on sides and rear. Top reinforced with welded hat channels and sound deadened. Constructed with uni-lok® patented gusset system with the gussets recessed into the hat channels to reduce lateral movement. Legs are 1½" O.D. stainless steel tubing, with stainless steel gussets and 1" stainless steel adjustable bullet feet.



worktable with upturn and tubular base
—shown with optional drawer

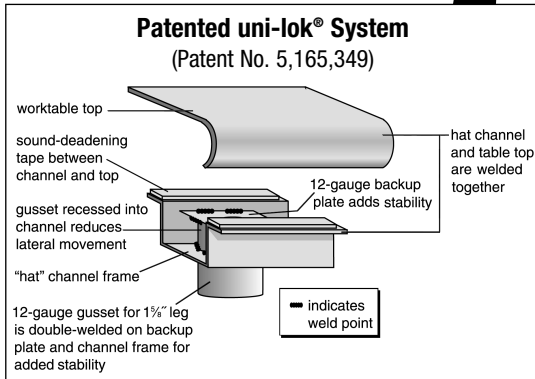

Item No.: _____
Project No.: _____
S.I.S. No.: _____

Worktables with Rear Upturn and Stainless Steel Tubular Base —Spec-Master® Series

MODELS:

- | | | | |
|------------------------------------|-------------------------------------|-------------------------------------|-------------------------------------|
| <input type="checkbox"/> UT2424STE | <input type="checkbox"/> UT24108STE | <input type="checkbox"/> UT3072STE | <input type="checkbox"/> UT3660STE |
| <input type="checkbox"/> UT2430STE | <input type="checkbox"/> UT24120STE | <input type="checkbox"/> UT3084STE | <input type="checkbox"/> UT3672STE |
| <input type="checkbox"/> UT2436STE | <input type="checkbox"/> UT24132STE | <input type="checkbox"/> UT3096STE | <input type="checkbox"/> UT3684STE |
| <input type="checkbox"/> UT2448STE | <input type="checkbox"/> UT24144STE | <input type="checkbox"/> UT30108STE | <input type="checkbox"/> UT3696STE |
| <input type="checkbox"/> UT2460STE | <input type="checkbox"/> UT3030STE | <input type="checkbox"/> UT30120STE | <input type="checkbox"/> UT36108STE |
| <input type="checkbox"/> UT2472STE | <input type="checkbox"/> UT3036STE | <input type="checkbox"/> UT30132STE | <input type="checkbox"/> UT36120STE |
| <input type="checkbox"/> UT2484STE | <input type="checkbox"/> UT3048STE | <input type="checkbox"/> UT30144STE | <input type="checkbox"/> UT36132STE |
| <input type="checkbox"/> UT2496STE | <input type="checkbox"/> UT3060STE | <input type="checkbox"/> UT3648STE | <input type="checkbox"/> UT36144STE |

Tabletop

- Top reinforced with welded-on hat channel.
- Sound-deadened between top and channels.
- 1½" (38mm) 90° rear upturn with radius at intersection.
- 1½" (41mm)-diameter 180° rolled edge on front. Ends are turned down 90° providing for flush installations when required.
- 14 gauge 300 series polished stainless steel.

Crossbracing—1¼" (32mm)-diameter

- Heavy gauge stainless steel.
- Aluminum castings join crossbraces, legs and rear brace.

Legs—1½" (41mm)-diameter

- Units 96" to 120" (2438 to 3048mm) long come with six legs; Units 132" and 144" (3353 and 3658mm) come with eight legs.
- Patented uni-lok® gusset system (patent # 5,165,349): gussets are recessed into hat channel, reducing lateral movement.
- Heavy gauge stainless steel.
- Galvanized gussets.
- 1" (25mm) adjustable stainless steel feet.

Options / Accessories

- | | |
|--|--|
| <input type="checkbox"/> Drawer | <input type="checkbox"/> Duplex receptacles |
| <input type="checkbox"/> Lock | <input type="checkbox"/> Pot rack |
| <input type="checkbox"/> Casters | <input type="checkbox"/> Sink |
| <input type="checkbox"/> Overshelves | <input type="checkbox"/> Additional undershelf |
| <input type="checkbox"/> Knockdown Welded Base (see back page) | <input type="checkbox"/> Stabilizer Bar (for 30"- and 36"-wide tables) |

EAGLE GROUP

100 Industrial Boulevard, Clayton, DE 19938-8903 USA
Phone: 302-653-3000 • 800-441-8440 • Fax: 302-653-2065
www.eaglegrp.com
www.eaglegrpnews.com
www.eaglemhc.com

For custom configuration or fabrication needs, contact our SpecFAB® Division.
Phone: 302-653-3000 • Fax: 302-653-2065 • e-mail: quotes@eaglegrp.com

Certifications / Approvals



AutoQuotes



EG10.49C Rev. 07/23

Spec sheets available for viewing, printing or downloading from our online literature library at our websites

Eagle Foodservice Equipment, Eagle MHC, and SpecFAB® are divisions of Eagle Group. ©2023 by the Eagle Group



Item No.: _____
 Project No.: _____
 S.I.S. No.: _____

Worktables with Rear Upturn and Stainless Steel Tubular Base—Spec-Master® Series

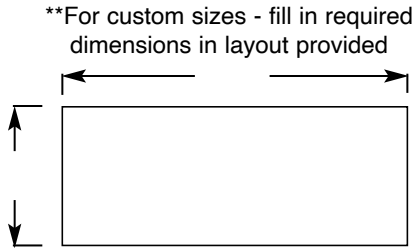

TOP VIEW

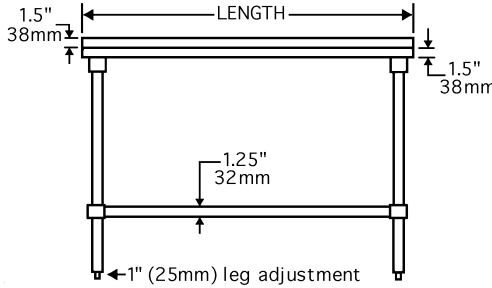

FRONT VIEW

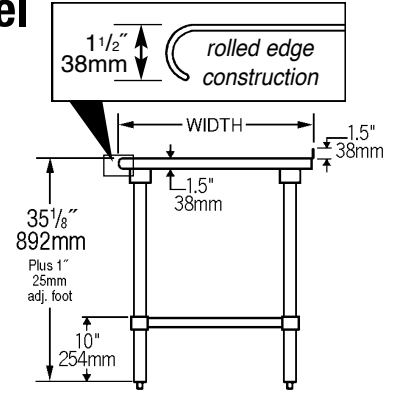

SIDE VIEW

model #	# of legs	width		length		weight	
		in.	mm	in.	mm	lbs.	kg
UT2424STE	4	24"	610	24"	610	44	20.0
UT2430STE	4	24"	610	30"	762	50	22.7
UT2436STE	4	24"	610	36"	914	55	24.9
UT2448STE	4	24"	610	48"	1219	66	29.9
UT2460STE	4	24"	610	60"	1524	77	34.9
UT2472STE	4	24"	610	72"	1829	88	39.9
UT2484STE	4	24"	610	84"	2134	99	44.9
UT2496STE	6	24"	610	96"	2438	110	49.9
UT24108STE	6	24"	610	108"	2743	121	54.9
UT24120STE	6	24"	610	120"	3048	132	59.9
UT24132STE	8	24"	610	132"	3353	143	64.9
UT24144STE	8	24"	610	144"	3658	154	69.9
UT3030STE	4	30"	762	30"	762	55	24.9
UT3036STE	4	30"	762	36"	914	58	26.3
UT3048STE	4	30"	762	48"	1219	63	28.6
UT3060STE	4	30"	762	60"	1524	74	33.6
UT3072STE	4	30"	762	72"	1829	85	38.6
UT3084STE	4	30"	762	84"	2134	96	43.6
UT3096STE	6	30"	762	96"	2438	107	48.5
UT30108STE	6	30"	762	108"	2743	118	53.5
UT30120STE	6	30"	762	120"	3048	129	58.5
UT30132STE	8	30"	762	132"	3353	140	63.5
UT30144STE	8	30"	762	144"	3658	151	68.5
UT3648STE	4	36"	914	48"	1219	67	30.4
UT3660STE	4	36"	914	60"	1524	79	35.8
UT3672STE	4	36"	914	72"	1829	94	42.6
UT3684STE	4	36"	914	84"	2134	107	48.5
UT3696STE	6	36"	914	96"	2438	120	54.4
UT36108STE	6	36"	914	108"	2743	133	60.3
UT36120STE	6	36"	914	120"	3048	146	66.2
UT36132STE	8	36"	914	132"	3353	160	72.6
UT36144STE	8	36"	914	144"	3658	173	78.5

NEW Option for Worktables with Stainless Steel Base: Knockdown Welded Base

PATENT PENDING

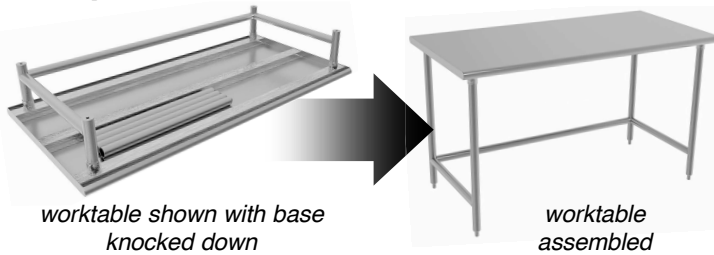

worktable shown with base knocked down

worktable assembled

- Precision machined stainless steel threaded inserts pressed into 16 gauge 1 1/8"-diameter leg sections for knockdown construction
- C-Frame stainless steel tubular base

Add suffix "-KDWB" to worktable model number (ex: UT2436STE-KDWB). See EG8217 for more info.

EAGLE GROUP

100 Industrial Boulevard, Clayton, DE 19938-8903 USA

Phone: 302-653-3000 or 800-441-8440 • Fax: 302-653-2065

www.eaglegrp.com • www.eaglegrpnews.com • www.eaglehmc.com

Printed in U.S.A.
 ©2023 by Eagle Group

Rev. 07/23

Spec sheets available for viewing, printing or downloading from our online literature library at our websites

Although every attempt has been made to ensure the accuracy of the information provided, we cannot be held responsible for typographical or printing errors. Information and specifications are subject to change without notice. Please confirm at time of order.