



Profit from the Eagle Advantage®

Specification Sheet

Short Form Specifications

Eagle worktables, Spec-Master® series, model _____.
 Top to be constructed of 14 gauge 300 series stainless steel with 1½" roll on front and rear, and sides turned down 90°. Open front with 1½" O.D. stainless steel tubular crossbracing on sides and rear. Top reinforced with welded hat channels and sound deadened. Constructed with uni-lok® patented gusset system with the gussets recessed into the hat channels to reduce lateral movement. Legs are 1½" O.D. stainless steel tubing, with stainless steel gussets and 1" stainless steel adjustable bullet feet.



worktable with flat top and tubular base
 —shown with optional drawer

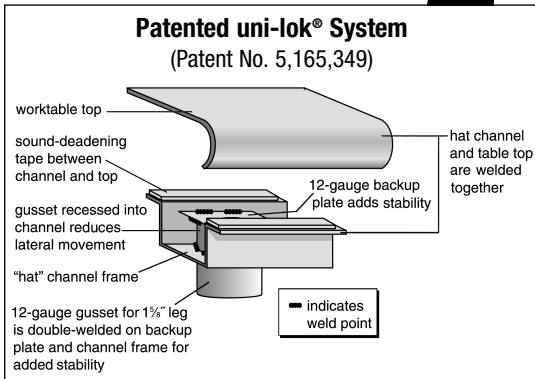

EAGLE GROUP

100 Industrial Boulevard, Clayton, DE 19938-8903 USA
 Phone: 302-653-3000 • 800-441-8440 • Fax: 302-653-2065
www.eaglegrp.com
www.eaglegrpnews.com
www.eaglemhc.com

For custom configuration or fabrication needs, contact our **SpecFAB® Division**.
 Phone: 302-653-3000 • Fax: 302-653-2065 • e-mail: quotes@eaglegrp.com

Item No.: _____
 Project No.: _____
 S.I.S. No.: _____

Worktables with Flat Top and Stainless Steel Tubular Base —Spec-Master® Series

MODELS:

- | | | | |
|------------------------------------|------------------------------------|------------------------------------|------------------------------------|
| <input type="checkbox"/> T2424STE | <input type="checkbox"/> T24144STE | <input type="checkbox"/> T30132STE | <input type="checkbox"/> T36144STE |
| <input type="checkbox"/> T2430STE | <input type="checkbox"/> T3030STE | <input type="checkbox"/> T30144STE | <input type="checkbox"/> T4848STE |
| <input type="checkbox"/> T2436STE | <input type="checkbox"/> T3036STE | <input type="checkbox"/> T3648STE | <input type="checkbox"/> T4860STE |
| <input type="checkbox"/> T2448STE | <input type="checkbox"/> T3048STE | <input type="checkbox"/> T3660STE | <input type="checkbox"/> T4872STE |
| <input type="checkbox"/> T2460STE | <input type="checkbox"/> T3060STE | <input type="checkbox"/> T3672STE | <input type="checkbox"/> T4884STE |
| <input type="checkbox"/> T2472STE | <input type="checkbox"/> T3072STE | <input type="checkbox"/> T3684STE | <input type="checkbox"/> T4896STE |
| <input type="checkbox"/> T2484STE | <input type="checkbox"/> T3084STE | <input type="checkbox"/> T3696STE | <input type="checkbox"/> T48108STE |
| <input type="checkbox"/> T2496STE | <input type="checkbox"/> T3096STE | <input type="checkbox"/> T36108STE | <input type="checkbox"/> T48120STE |
| <input type="checkbox"/> T24108STE | <input type="checkbox"/> T30108STE | <input type="checkbox"/> T36120STE | <input type="checkbox"/> T48132STE |
| <input type="checkbox"/> T24120STE | <input type="checkbox"/> T30120STE | <input type="checkbox"/> T36132STE | <input type="checkbox"/> T48144STE |
| <input type="checkbox"/> T24132STE | | | |

Tabletop

- Patented uni-lok® gusset system (patent #5,165,349): gussets are recessed into hat channel, reducing lateral movement.
- Top reinforced with welded-on hat channel.
- Sound-deadened between top and channels.
- 1½" (38mm)-diameter 180° rolled edges on front and rear. Ends are turned down 90°, providing for flush installations when required.
- 14 gauge 300 series polished stainless steel.

Crossbracing—1½" (38mm)-diameter

- Heavy gauge stainless steel.
- Aluminum castings join crossbraces, legs and rear brace.

Legs—1½" (41mm)-diameter

- 24" to 36" (610 to 914mm)-wide units that are 96" (2438mm) and longer come with six legs or more. 48" (1219mm)-wide units that are 72" (1829mm) and longer come with six legs or more.
- Heavy gauge stainless steel.
- 1" (25mm) adjustable stainless steel feet.

Options / Accessories

- | | |
|--|--|
| <input type="checkbox"/> Drawer | <input type="checkbox"/> Duplex receptacles |
| <input type="checkbox"/> Lock | <input type="checkbox"/> Pot rack |
| <input type="checkbox"/> Casters | <input type="checkbox"/> Sink |
| <input type="checkbox"/> Overshelves | <input type="checkbox"/> Stabilizer Bar (for 30"- and 36"-wide tables) |
| <input type="checkbox"/> Knockdown Welded Base (see back page) | |

Certifications / Approvals



EG10.43C Rev. 07/23

Spec sheets available for viewing, printing or downloading from our online literature library at our websites

Eagle Foodservice Equipment, Eagle MHC, and SpecFAB® are divisions of Eagle Group. ©2023 by the Eagle Group



Item No.: _____
 Project No.: _____
 S.I.S. No.: _____

Worktables with Flat Top and Stainless Steel Tubular Base—Spec-Master® Series

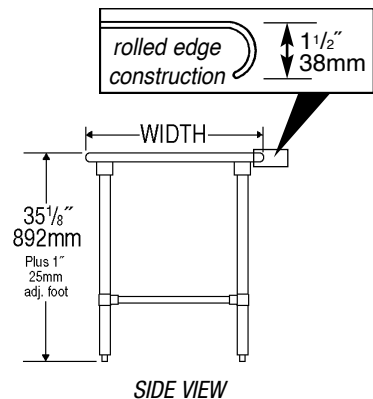
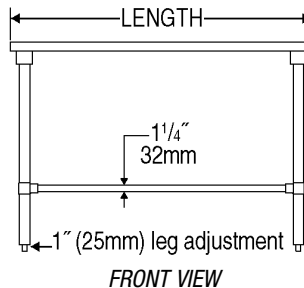
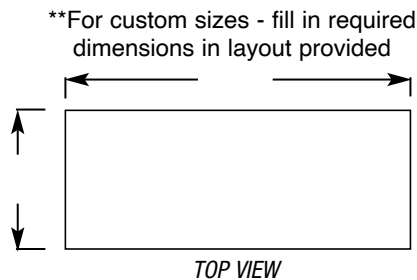

model #	# of legs	width		length		weight	
		in.	mm	in.	mm	lbs.	kg
T2424STE	4	24"	610	24"	610	44	20.0
T2430STE	4	24"	610	30"	762	48	21.8
T2436STE	4	24"	610	36"	914	55	24.9
T2448STE	4	24"	610	48"	1219	66	29.9
T2460STE	4	24"	610	60"	1524	77	34.9
T2472STE	4	24"	610	72"	1829	88	39.9
T2484STE	4	24"	610	84"	2134	99	44.9
T2496STE	6	24"	610	96"	2438	110	49.9
T24108STE	6	24"	610	108"	2743	121	54.9
T24120STE	6	24"	610	120"	3048	132	59.9
T24132STE	8	24"	610	132"	3353	145	65.8
T24144STE	8	24"	610	144"	3658	154	69.9
T3030STE	4	30"	762	30"	762	52	23.6
T3036STE	4	30"	762	36"	914	58	26.3
T3048STE	4	30"	762	48"	1219	72	32.7
T3060STE	4	30"	762	60"	1524	85	38.6
T3072STE	4	30"	762	72"	1829	98	44.5
T3084STE	4	30"	762	84"	2134	111	50.3
T3096STE	6	30"	762	96"	2438	124	56.2
T30108STE	6	30"	762	108"	2743	138	62.6
T30120STE	6	30"	762	120"	3048	151	68.5
T30132STE	8	30"	762	132"	3353	164	74.4
T30144STE	8	30"	762	144"	3658	177	80.3
T3648STE	4	36"	914	48"	1219	80	36.3
T3660STE	4	36"	914	60"	1524	96	43.6
T3672STE	4	36"	914	72"	1829	111	50.3
T3684STE	4	36"	914	84"	2134	127	57.6
T3696STE	6	36"	914	96"	2438	142	64.4
T36108STE	6	36"	914	108"	2743	157	71.2
T36120STE	6	36"	914	120"	3048	172	78.0
T36132STE	8	36"	914	132"	3353	188	85.3
T36144STE	8	36"	914	144"	3658	204	92.5
T4848STE	4	48"	1219	48"	1219	96	43.6
T4860STE	4	48"	1219	60"	1524	111	50.3
T4872STE	6	48"	1219	72"	1829	127	57.6
T4884STE	6	48"	1219	84"	2134	132	59.9
T4896STE	8	48"	1219	96"	2438	157	71.2
T48108STE	8	48"	1219	108"	2743	173	78.5
T48120STE	8	48"	1219	120"	3048	188	85.3
T48132STE	8	48"	1219	132"	3353	204	92.5
T48144STE	8	48"	1219	144"	3658	219	99.3

NEW Option for Worktables with Stainless Steel Base: Knockdown Welded Base

PATENT PENDING

worktable with base knocked down

worktable assembled

- Precision machined stainless steel threaded inserts pressed into 16 gauge 1 1/8"-diameter leg sections for knockdown construction
- Marine edge stainless steel undershelf welded to lower leg sections

Add suffix "**-KDWB**" to worktable model number (ex: T3060STE-KDWB). See EG8217 for more info.

EAGLE GROUP
 100 Industrial Boulevard, Clayton, DE 19938-8903 USA
 Phone: 302-653-3000 or 800-441-8440 • Fax: 302-653-2065
 www.eaglegrp.com • www.eaglegrpnews.com • www.eaglehmc.com

Printed in U.S.A.
 ©2023 by Eagle Group
 Rev. 07/23

Spec sheets available for viewing, printing or downloading from our online literature library at our websites

Although every attempt has been made to ensure the accuracy of the information provided, we cannot be held responsible for typographical or printing errors. Information and specifications are subject to change without notice. Please confirm at time of order.