



Profit from the Eagle Advantage®

Specification Sheet

Short Form Specifications

Eagle worktables, Spec-Master® series, model _____.
 Top constructed of 14 gauge 300 series stainless steel, with 1½" roll on front and rear, and sides turned down 90°. Undershef is adjustable and constructed of 18 gauge 300 series stainless steel with marine edge. Top reinforced with stainless steel hat channels and sound deadened. Constructed with uni-lok® patented gusset system with the gussets recessed into the hat channels to reduce lateral movement. Legs are 1½" O.D., stainless steel, with stainless steel gussets and 1" stainless steel adjustable bullet feet.

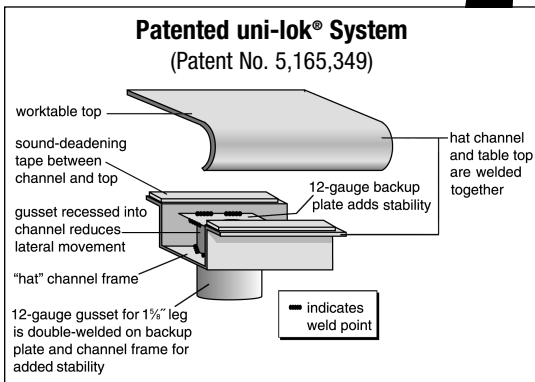

Item No.: _____
 Project No.: _____
 S.I.S. No.: _____

Worktables with Flat Top and Stainless Steel Base with Undershef—Spec-Master® Series

MODELS:

- | | | | |
|-----------------------------------|-----------------------------------|-----------------------------------|-----------------------------------|
| <input type="checkbox"/> T2424SE | <input type="checkbox"/> T24144SE | <input type="checkbox"/> T30132SE | <input type="checkbox"/> T36144SE |
| <input type="checkbox"/> T2430SE | <input type="checkbox"/> T3030SE | <input type="checkbox"/> T30144SE | <input type="checkbox"/> T4848SE |
| <input type="checkbox"/> T2436SE | <input type="checkbox"/> T3036SE | <input type="checkbox"/> T3648SE | <input type="checkbox"/> T4860SE |
| <input type="checkbox"/> T2448SE | <input type="checkbox"/> T3048SE | <input type="checkbox"/> T3660SE | <input type="checkbox"/> T4872SE |
| <input type="checkbox"/> T2460SE | <input type="checkbox"/> T3060SE | <input type="checkbox"/> T3672SE | <input type="checkbox"/> T4884SE |
| <input type="checkbox"/> T2472SE | <input type="checkbox"/> T3072SE | <input type="checkbox"/> T3684SE | <input type="checkbox"/> T4896SE |
| <input type="checkbox"/> T2484SE | <input type="checkbox"/> T3084SE | <input type="checkbox"/> T3696SE | <input type="checkbox"/> T48108SE |
| <input type="checkbox"/> T2496SE | <input type="checkbox"/> T3096SE | <input type="checkbox"/> T36108SE | <input type="checkbox"/> T48120SE |
| <input type="checkbox"/> T24108SE | <input type="checkbox"/> T30108SE | <input type="checkbox"/> T36120SE | <input type="checkbox"/> T48132SE |
| <input type="checkbox"/> T24120SE | <input type="checkbox"/> T30120SE | <input type="checkbox"/> T36132SE | <input type="checkbox"/> T48144SE |
| <input type="checkbox"/> T24132SE | | | |

Tabletop

- Patented uni-lok® gusset system (patent #5,165,349): gussets are recessed into hat channel, reducing lateral movement.
- Top reinforced with welded-on hat channel.
- Sound-deadened between top and channels.
- 1½" (38mm)-diameter 180° rolled edges on front and rear. Ends are turned down 90° providing for flush installations when required.
- 14 gauge 300 series polished stainless steel.

Adjustable Undershef

- 18 gauge 300 series stainless steel.
- Gusset welded to each corner.
- Heavy duty marine edge design.

Legs—1½" (41mm)-diameter

- 24" to 36" (610 to 914mm)-wide units that are 96" (2438mm) and longer come with six legs or more. 48" (1219mm)-wide units that are 72" (1829mm) and longer come with six legs or more.
- Heavy gauge stainless steel.
- 1" (25mm) adjustable stainless steel feet.

Options / Accessories

- | | |
|--|--|
| <input type="checkbox"/> Drawer | <input type="checkbox"/> Duplex receptacles |
| <input type="checkbox"/> Lock | <input type="checkbox"/> Pot rack |
| <input type="checkbox"/> Casters | <input type="checkbox"/> Sink |
| <input type="checkbox"/> Overshelves | <input type="checkbox"/> Additional undershef |
| <input type="checkbox"/> Knockdown Welded Base (see back page) | <input type="checkbox"/> Stabilizer Bar (for 30"- and 36"-wide tables) |

Certifications / Approvals



EAGLE GROUP

100 Industrial Boulevard, Clayton, DE 19938-8903 USA
 Phone: 302-653-3000 • 800-441-8440 • Fax: 302-653-2065
www.eaglegrp.com
www.eaglegrpnews.com
www.eaglemhc.com

For custom configuration or fabrication needs, contact our SpecFAB® Division.
 Phone: 302-653-3000 • Fax: 302-653-2065 • e-mail: quotes@eaglegrp.com

EG10.41C Rev. 07/23

Spec sheets available for viewing, printing or downloading from our online literature library at our websites

Eagle Foodservice Equipment, Eagle MHC, and SpecFAB® are divisions of Eagle Group. ©2023 by the Eagle Group



Profit from the Eagle Advantage®

Item No.: _____
 Project No.: _____
 S.I.S. No.: _____

Worktables with Flat Top and Stainless Steel Base with Undershelf—Spec-Master® Series

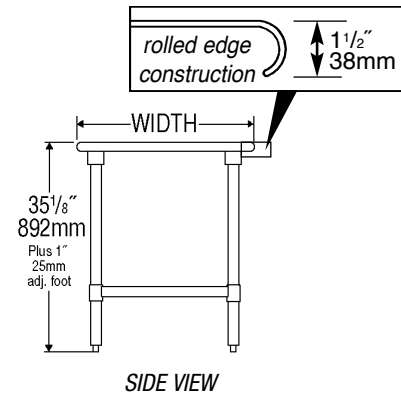
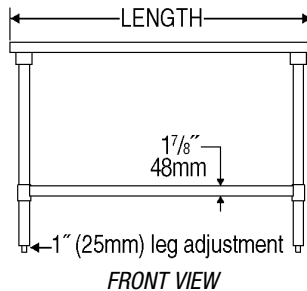
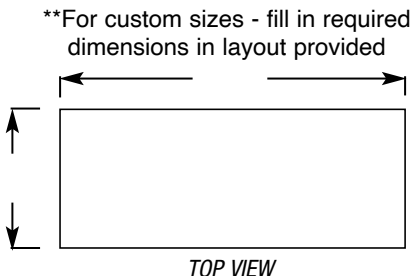

| model # | # of legs | width | | length | | weight | |
|----------|-----------|-------|------|--------|------|--------|-------|
| | | in. | mm | in. | mm | lbs. | kg |
| T2424SE | 4 | 24" | 610 | 24" | 610 | 46 | 20.9 |
| T2430SE | 4 | 24" | 610 | 30" | 762 | 50 | 22.7 |
| T2436SE | 4 | 24" | 610 | 36" | 914 | 55 | 24.9 |
| T2448SE | 4 | 24" | 610 | 48" | 1219 | 67 | 30.4 |
| T2460SE | 4 | 24" | 610 | 60" | 1524 | 78 | 35.4 |
| T2472SE | 4 | 24" | 610 | 72" | 1829 | 90 | 40.8 |
| T2484SE | 4 | 24" | 610 | 84" | 2134 | 103 | 46.3 |
| T2496SE | 6 | 24" | 610 | 96" | 2438 | 125 | 56.7 |
| T24108SE | 6 | 24" | 610 | 108" | 2743 | 144 | 65.3 |
| T24120SE | 6 | 24" | 610 | 120" | 3048 | 163 | 73.9 |
| T24132SE | 8 | 24" | 610 | 132" | 3353 | 186 | 84.4 |
| T24144SE | 8 | 24" | 610 | 144" | 3658 | 200 | 90.7 |
| T3030SE | 4 | 30" | 762 | 30" | 762 | 54 | 24.5 |
| T3036SE | 4 | 30" | 762 | 36" | 914 | 57 | 25.9 |
| T3048SE | 4 | 30" | 762 | 48" | 1219 | 75 | 34.0 |
| T3060SE | 4 | 30" | 762 | 60" | 1524 | 87 | 39.5 |
| T3072SE | 4 | 30" | 762 | 72" | 1829 | 101 | 45.8 |
| T3084SE | 4 | 30" | 762 | 84" | 2134 | 116 | 52.6 |
| T3096SE | 6 | 30" | 762 | 96" | 2438 | 139 | 63.1 |
| T30108SE | 6 | 30" | 762 | 108" | 2743 | 161 | 73.0 |
| T30120SE | 6 | 30" | 762 | 120" | 3048 | 182 | 82.6 |
| T30132SE | 8 | 30" | 762 | 132" | 3353 | 204 | 92.5 |
| T30144SE | 8 | 30" | 762 | 144" | 3658 | 224 | 101.6 |
| T3648SE | 4 | 36" | 914 | 48" | 1219 | 83 | 37.6 |
| T3660SE | 4 | 36" | 914 | 60" | 1524 | 97 | 44.0 |
| T3672SE | 4 | 36" | 914 | 72" | 1829 | 114 | 51.7 |
| T3684SE | 4 | 36" | 914 | 84" | 2134 | 132 | 59.9 |
| T3696SE | 6 | 36" | 914 | 96" | 2438 | 153 | 69.4 |
| T36108SE | 6 | 36" | 914 | 108" | 2743 | 180 | 81.6 |
| T36120SE | 6 | 36" | 914 | 120" | 3048 | 207 | 93.9 |
| T36132SE | 8 | 36" | 914 | 132" | 3353 | 234 | 106.1 |
| T36144SE | 8 | 36" | 914 | 144" | 3658 | 261 | 118.4 |
| T4848SE | 4 | 48" | 1219 | 48" | 1219 | 136 | 61.7 |
| T4860SE | 4 | 48" | 1219 | 60" | 1524 | 161 | 73.0 |
| T4872SE | 6 | 48" | 1219 | 72" | 1829 | 188 | 85.3 |
| T4884SE | 6 | 48" | 1219 | 84" | 2134 | 217 | 98.4 |
| T4896SE | 8 | 48" | 1219 | 96" | 2438 | 265 | 120.2 |
| T48108SE | 8 | 48" | 1219 | 108" | 2743 | 306 | 138.8 |
| T48120SE | 8 | 48" | 1219 | 120" | 3048 | 348 | 157.9 |
| T48132SE | 8 | 48" | 1219 | 132" | 3353 | 388 | 176.0 |
| T48144SE | 8 | 48" | 1219 | 144" | 3658 | 430 | 195.0 |

NEW Option for Worktables with Stainless Steel Base: Knockdown Welded Base

PATENT PENDING

worktable with base knocked down

worktable assembled

- Precision machined stainless steel threaded inserts pressed into 16 gauge 1 1/2"-diameter leg sections for knockdown construction
- Marine edge stainless steel undershelf welded to lower leg sections

Add suffix **"-KDWB"** to worktable model number (ex: T3060SE-KDWB). See EG8217 for more info.

EAGLE GROUP
 100 Industrial Boulevard, Clayton, DE 19938-8903 USA
 Phone: 302-653-3000 or 800-441-8440 • Fax: 302-653-2065
 www.eaglegrp.com • www.eaglegrpnews.com • www.eaglehmc.com

Printed in U.S.A.
 ©2023 by Eagle Group
 Rev. 07/23

Spec sheets available for viewing, printing or downloading from our online literature library at our websites

Although every attempt has been made to ensure the accuracy of the information provided, we cannot be held responsible for typographical or printing errors. Information and specifications are subject to change without notice. Please confirm at time of order.