



Profit from the Eagle Advantage®

Specification Sheet

Short Form Specifications

Eagle Spec-Master® Marine Counter Edge Cabinets with Upturn, model _____. Top is 14/304 stainless steel, sides and back are heavy gauge stainless steel. Open front, stainless steel sliding doors, or stainless steel hinged doors. Marine counter edge on front and sides, 1½" upturn at rear. Constructed with uni-lok® patented gusset system, with the gussets recessed into channels, to reduce lateral movement. 1½" O.D. stainless steel tubular legs with adjustable stainless steel bullet feet.



cabinet with sliding doors

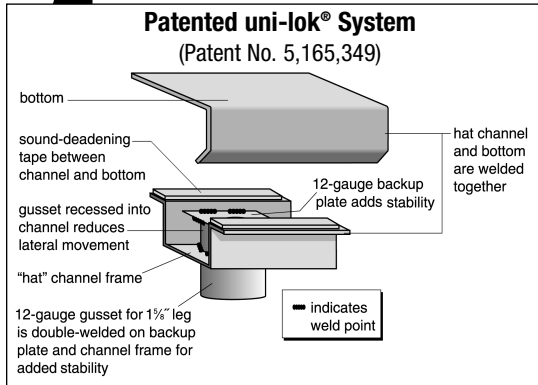

Item No.: _____
 Project No.: _____
 S.I.S. No.: _____

Spec-Master® Marine Counter Edge Cabinets with Upturn

MODELS:

- | | | |
|--------------------------------------|--------------------------------------|---------------------------------------|
| <input type="checkbox"/> UOB2436SEM | <input type="checkbox"/> UCB2436SEM | <input type="checkbox"/> UCBH2436SEM |
| <input type="checkbox"/> UOB2448SEM | <input type="checkbox"/> UCB2448SEM | <input type="checkbox"/> UCBH2448SEM |
| <input type="checkbox"/> UOB2460SEM | <input type="checkbox"/> UCB2460SEM | <input type="checkbox"/> UCBH2460SEM |
| <input type="checkbox"/> UOB2472SEM | <input type="checkbox"/> UCB2472SEM | <input type="checkbox"/> UCBH2472SEM |
| <input type="checkbox"/> UOB2484SEM | <input type="checkbox"/> UCB2484SEM | <input type="checkbox"/> UCBH2484SEM |
| <input type="checkbox"/> UOB2496SEM | <input type="checkbox"/> UCB2496SEM | <input type="checkbox"/> UCBH2496SEM |
| <input type="checkbox"/> UOB24120SEM | <input type="checkbox"/> UCB24120SEM | <input type="checkbox"/> UCBH24120SEM |
| <input type="checkbox"/> UOB3036SEM | <input type="checkbox"/> UCB3036SEM | <input type="checkbox"/> UCBH3036SEM |
| <input type="checkbox"/> UOB3048SEM | <input type="checkbox"/> UCB3048SEM | <input type="checkbox"/> UCBH3048SEM |
| <input type="checkbox"/> UOB3060SEM | <input type="checkbox"/> UCB3060SEM | <input type="checkbox"/> UCBH3060SEM |
| <input type="checkbox"/> UOB3072SEM | <input type="checkbox"/> UCB3072SEM | <input type="checkbox"/> UCBH3072SEM |
| <input type="checkbox"/> UOB3084SEM | <input type="checkbox"/> UCB3084SEM | <input type="checkbox"/> UCBH3084SEM |
| <input type="checkbox"/> UOB3096SEM | <input type="checkbox"/> UCB3096SEM | <input type="checkbox"/> UCBH3096SEM |
| <input type="checkbox"/> UOB30120SEM | <input type="checkbox"/> UCB30120SEM | <input type="checkbox"/> UCBH30120SEM |

Tabletop

- 14 gauge type 304 stainless steel.
- Reinforced with full length "hat" channel support.
- Marine counter edge set in 1" (25mm), on front and sides, designed to retard spillage.
- 1½" (38mm) full-length upturn at rear.

Cabinet

- Cabinet body is heavy gauge stainless steel.
- Available with open front, or with 20 gauge stainless steel sliding or hinged doors*.
- Bottom panel features an offset designed to retard spillage.

Legs

- uni-lok® leg/gusset channel assembly (patent #5,165,349).
- Adjustable stainless bullet feet—1" (25mm) adjustment.

Options / Accessories

- Center shelf**

* Cabinets 84" (2134mm) and longer have two sets of sliding or hinged doors.

** To order center shelf, add suffix "-CS". Example: UCB3036SEM-CS

EAGLE GROUP

100 Industrial Boulevard, Clayton, DE 19938-8903 USA
 Phone: 302-653-3000 • 800-441-8440 • Fax: 302-653-2065
 www.eaglegrp.com
 www.eaglemhc.com

For custom configuration or fabrication needs, contact our SpecFAB® Division.

Phone: 302-653-3000 • Fax: 302-653-2065 • e-mail: quotes@eaglegrp.com

Certifications / Approvals



AutoQuotes



EG10.33B Rev. 10/23

Spec sheets available for viewing, printing or downloading from our online literature library at our websites



Profit from the Eagle Advantage®

Item No.: _____
 Project No.: _____
 S.I.S. No.: _____

Spec-Master® Marine Counter Edge Cabinets with Open Front

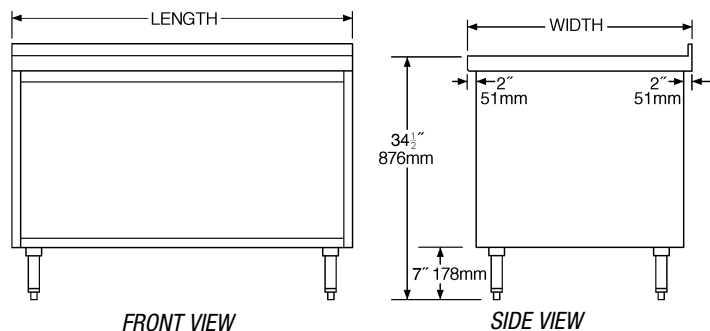

model #	# of legs	width in. mm	length in. mm	weight lbs. kg
UOB2436SEM	4	24" 610	36" 914	132 59.9
UOB2448SEM	4	24" 610	48" 1219	160 72.6
UOB2460SEM	4	24" 610	60" 1524	200 90.7
UOB2472SEM	4	24" 610	72" 1829	240 108.9
UOB2484SEM	6	24" 610	84" 2134	281 127.5
UOB2496SEM	6	24" 610	96" 2438	322 146.1
UOB24120SEM	6	24" 610	120" 3048	366 166.0
UOB3036SEM	4	30" 762	36" 914	136 61.7
UOB3048SEM	4	30" 762	48" 1219	166 75.3
UOB3060SEM	4	30" 762	60" 1524	199 90.3
UOB3072SEM	4	30" 762	72" 1829	248 112.5
UOB3084SEM	6	30" 762	84" 2134	294 133.4
UOB3096SEM	6	30" 762	96" 2438	340 154.2
UOB30120SEM	6	30" 762	120" 3048	432 196.0

Spec-Master® Marine Counter Edge Cabinets with Sliding Doors

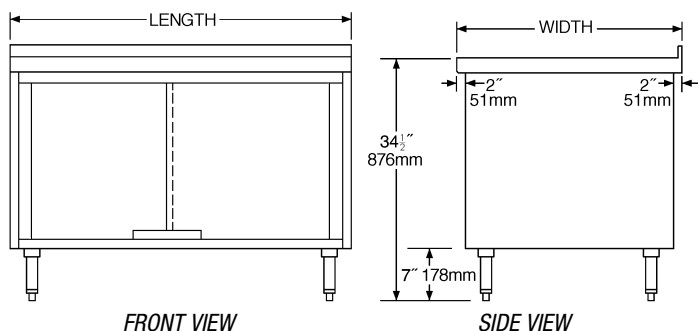

model #	# of legs	width in. mm	length in. mm	weight lbs. kg
UCB2436SEM	4	24" 610	36" 914	138 62.6
UCB2448SEM	4	24" 610	48" 1219	170 77.1
UCB2460SEM	4	24" 610	60" 1524	212 96.2
UCB2472SEM	4	24" 610	72" 1829	254 115.2
UCB2484SEM*	6	24" 610	84" 2134	299 135.6
UCB2496SEM*	6	24" 610	96" 2438	339 153.8
UCB24120SEM*	6	24" 610	120" 3048	384 174.2
UCB3036SEM	4	30" 762	36" 914	142 64.4
UCB3048SEM	4	30" 762	48" 1219	173 78.5
UCB3060SEM	4	30" 762	60" 1524	219 99.3
UCB3072SEM	4	30" 762	72" 1829	261 118.4
UCB3084SEM*	6	30" 762	84" 2134	312 141.5
UCB3096SEM*	6	30" 762	96" 2438	350 158.8
UCB30120SEM*	6	30" 762	120" 3048	450 204.1

* Note: Worktables 84" (2134mm) and longer have *two* sets of doors.

Spec-Master® Marine Counter Edge Cabinets with Hinged Doors

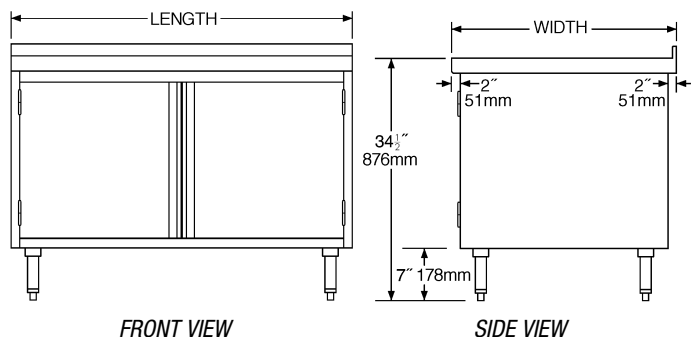

model #	# of legs	width in. mm	length in. mm	weight lbs. kg
UCBH2436SEM	4	24" 610	36" 914	138 62.6
UCBH2448SEM	4	24" 610	48" 1219	170 77.1
UCBH2460SEM	4	24" 610	60" 1524	212 96.2
UCBH2472SEM	6	24" 610	72" 1829	254 115.2
UCBH2484SEM*	6	24" 610	84" 2134	299 135.6
UCBH2496SEM*	6	24" 610	96" 2438	339 153.8
UCBH24120SEM*	6	24" 610	120" 3048	384 174.2
UCBH3036SEM	4	30" 762	36" 914	142 64.4
UCBH3048SEM	4	30" 762	48" 1219	173 78.5
UCBH3060SEM	4	30" 762	60" 1524	219 99.3
UCBH3072SEM	4	30" 762	72" 1829	261 118.4
UCBH3084SEM*	6	30" 762	84" 2134	312 141.5
UCBH3096SEM*	6	30" 762	96" 2438	350 158.8
UCBH30120SEM*	6	30" 762	120" 3048	450 204.1

* Note: Worktables 84" (2134mm) and longer have *two* sets of doors.

EAGLE GROUP
 100 Industrial Boulevard, Clayton, DE 19938-8903 USA
 Phone: 302-653-3000 or 800-441-8440 • Fax: 302-653-2065
 www.eaglegrp.com • www.eaglehmc.com

Printed in U.S.A.
 ©2023 by Eagle Group

Rev. 10/23

Spec sheets available for viewing, printing or downloading from our online literature library at our websites

Although every attempt has been made to ensure the accuracy of the information provided, we cannot be held responsible for typographical or printing errors. Information and specifications are subject to change without notice. Please confirm at time of order.