



Profit from the Eagle Advantage®

Specification Sheet

Short Form Specifications

Eagle Spec-Master® Enclosed Base Worktable, model _____ . Top is 14/304 stainless steel, sides and back are heavy gauge stainless steel. (Open Front, Stainless Steel Sliding Door, or Stainless Steel Hinged Door) models with 1½" rolled edge on front, sides turned down, and 4" backsplash on rear. Constructed with uni-lok® patented gusset system, with the gussets recessed into the hat channels to reduce lateral movement. 1½" O.D. stainless steel tubular legs with adjustable bullet feet.



enclosed worktable with hinged doors

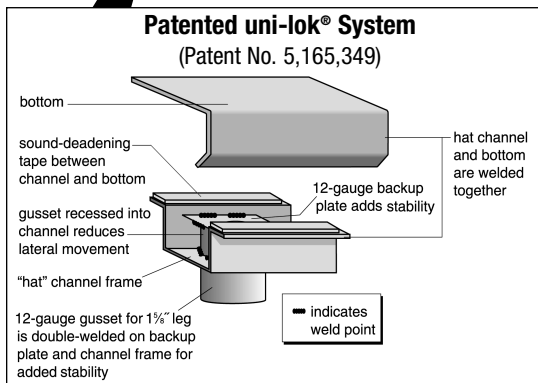

Item No.: _____
 Project No.: _____
 S.I.S. No.: _____

Spec-Master® Enclosed Worktables with Backsplash

MODELS:

- | | | |
|---------------------------------------|---------------------------------------|--|
| <input type="checkbox"/> OB2436SE-BS | <input type="checkbox"/> CB2436SE-BS | <input type="checkbox"/> CBH2436SE-BS |
| <input type="checkbox"/> OB2448SE-BS | <input type="checkbox"/> CB2448SE-BS | <input type="checkbox"/> CBH2448SE-BS |
| <input type="checkbox"/> OB2460SE-BS | <input type="checkbox"/> CB2460SE-BS | <input type="checkbox"/> CBH2460SE-BS |
| <input type="checkbox"/> OB2472SE-BS | <input type="checkbox"/> CB2472SE-BS | <input type="checkbox"/> CBH2472SE-BS |
| <input type="checkbox"/> OB2484SE-BS | <input type="checkbox"/> CB2484SE-BS | <input type="checkbox"/> CBH2484SE-BS |
| <input type="checkbox"/> OB2496SE-BS | <input type="checkbox"/> CB2496SE-BS | <input type="checkbox"/> CBH2496SE-BS |
| <input type="checkbox"/> OB24120SE-BS | <input type="checkbox"/> CB24120SE-BS | <input type="checkbox"/> CBH24120SE-BS |
| <input type="checkbox"/> OB3036SE-BS | <input type="checkbox"/> CB3036SE-BS | <input type="checkbox"/> CBH3036SE-BS |
| <input type="checkbox"/> OB3048SE-BS | <input type="checkbox"/> CB3048SE-BS | <input type="checkbox"/> CBH3048SE-BS |
| <input type="checkbox"/> OB3060SE-BS | <input type="checkbox"/> CB3060SE-BS | <input type="checkbox"/> CBH3060SE-BS |
| <input type="checkbox"/> OB3072SE-BS | <input type="checkbox"/> CB3072SE-BS | <input type="checkbox"/> CBH3072SE-BS |
| <input type="checkbox"/> OB3084SE-BS | <input type="checkbox"/> CB3084SE-BS | <input type="checkbox"/> CBH3084SE-BS |
| <input type="checkbox"/> OB3096SE-BS | <input type="checkbox"/> CB3096SE-BS | <input type="checkbox"/> CBH3096SE-BS |
| <input type="checkbox"/> OB30120SE-BS | <input type="checkbox"/> CB30120SE-BS | <input type="checkbox"/> CBH30120SE-BS |

Features

- All-welded design.
- Available with open front, sliding doors, or hinged doors.
- Doors are 20 gauge type 430 stainless steel.
- Top mechanically polished to satin finish.
- Top is 14 gauge type 304 stainless steel reinforced with a full length "hat" channel support.
- Body is heavy gauge type 430 stainless steel.
- Sound-deadened between top and frame.
- 1½" (42mm)-diameter type 304 stainless legs.
- 1" (25mm) adjustable stainless steel feet.
- 1½" (38mm) sanitary rolled rim on front.
- 4½" (114mm) backsplash on rear.
- Square edge on ends for flush fit.
- Optional fixed center shelf available. To order, add suffix "-CS" to model number. Example: OB2436SE-BS-CS

Options / Accessories

- | | |
|--|--|
| <input type="checkbox"/> Lock (for units with doors) | <input type="checkbox"/> Center shelf |
| <input type="checkbox"/> Casters* | <input type="checkbox"/> Sound deadening |
| <input type="checkbox"/> Overshelf | |

* To order table with 4" (102mm)-diameter casters, add suffix "-CA" (ex: OB3048SE-BS-CA). To order table with 5" (127mm)-diameter casters, add suffix "-CAH" (ex: CB3048SE-BS-CAH).

EAGLE GROUP

100 Industrial Boulevard, Clayton, DE 19938-8903 USA
 Phone: 302-653-3000 • 800-441-8440 • Fax: 302-653-2065
 www.eaglegrp.com
 www.eaglehmc.com

For custom configuration or fabrication needs, contact our SpecFAB® Division.
 Phone: 302-653-3000 • Fax: 302-653-2065 • e-mail: quotes@eaglegrp.com



EG10.32 Rev. 11/23

Spec sheets available for viewing, printing or downloading from our online literature library at our websites



Item No.: _____
 Project No.: _____
 S.I.S. No.: _____

Spec-Master® Enclosed Worktables with Open Front

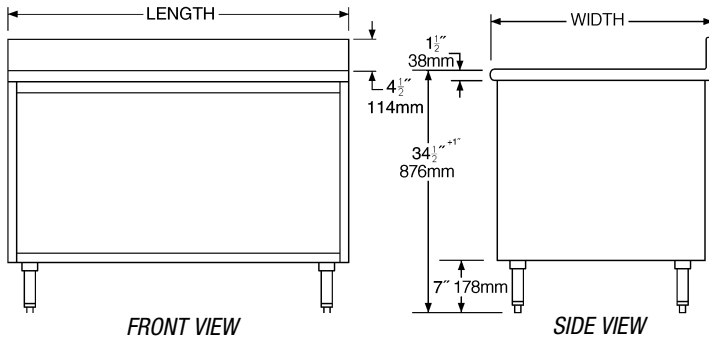

model #	width		length		weight		no. of legs
	in.	mm	in.	mm	lbs.	kg	
OB2436SE-BS	24"	610	36"	914	183	83.0	4
OB2448SE-BS	24"	610	48"	1219	242	109.8	4
OB2460SE-BS	24"	610	60"	1524	302	137.0	4
OB2472SE-BS	24"	610	72"	1829	361	163.8	4
OB2484SE-BS	24"	610	84"	2134	421	191.0	6
OB2496SE-BS	24"	610	96"	2438	480	217.7	6
OB24120SE-BS	24"	610	120"	3048	599	271.7	6
OB3036SE-BS	30"	762	36"	914	190	86.2	4
OB3048SE-BS	30"	762	48"	1219	252	114.3	4
OB3060SE-BS	30"	762	60"	1524	308	139.7	4
OB3072SE-BS	30"	762	72"	1829	375	170.1	4
OB3084SE-BS	30"	762	84"	2134	431	195.5	6
OB3096SE-BS	30"	762	96"	2438	498	225.9	6
OB30120SE-BS	30"	762	120"	3048	620	281.2	6

Spec-Master® Enclosed Worktables with Sliding Doors

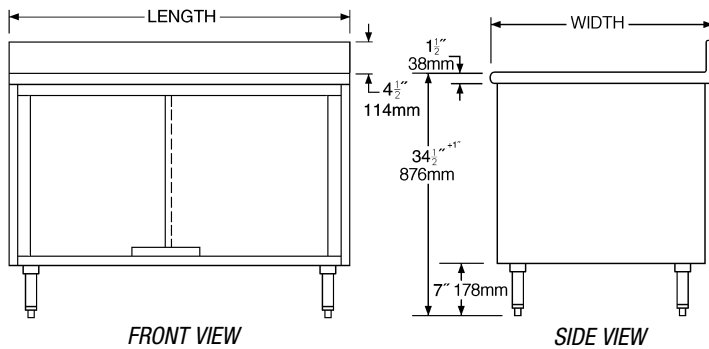

model #	width		length		weight		no. of legs
	in.	mm	in.	mm	lbs.	kg	
CB2436SE-BS	24"	610	36"	914	190	86.2	4
CB2448SE-BS	24"	610	48"	1219	253	114.8	4
CB2460SE-BS	24"	610	60"	1524	315	142.9	4
CB2472SE-BS	24"	610	72"	1829	373	169.2	4
CB2484SE-BS*	24"	610	84"	2134	439	199.1	6
CB2496SE-BS*	24"	610	96"	2438	501	227.3	6
CB24120SE-BS*	24"	610	120"	3048	625	283.5	6
CB3036SE-BS	30"	762	36"	914	202	91.6	4
CB3048SE-BS	30"	762	48"	1219	274	124.3	4
CB3060SE-BS	30"	762	60"	1524	340	154.2	4
CB3072SE-BS	30"	762	72"	1829	408	185.1	4
CB3084SE-BS*	30"	762	84"	2134	475	215.5	6
CB3096SE-BS*	30"	762	96"	2438	543	246.3	6
CB30120SE-BS*	30"	762	120"	3048	676	306.6	6

* Note: Worktables 84" (2134mm) and longer have two sets of doors.

Spec-Master® Enclosed Worktables with Hinged Doors

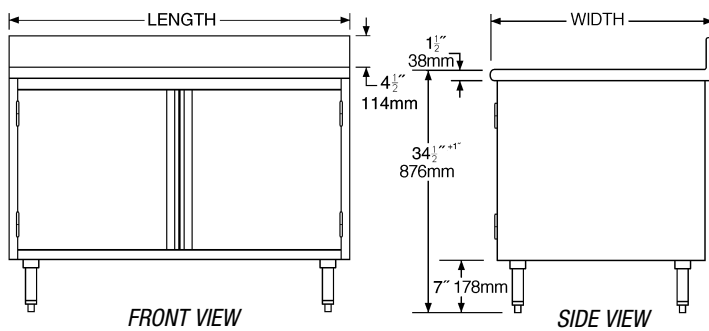

model #	width		length		weight		no. of legs
	in.	mm	in.	mm	lbs.	kg	
CBH2436SE-BS	24"	610	36"	914	201	91.2	4
CBH2448SE-BS	24"	610	48"	1219	267	121.1	4
CBH2460SE-BS	24"	610	60"	1524	332	150.6	4
CBH2472SE-BS	24"	610	72"	1829	398	180.5	4
CBH2484SE-BS*	24"	610	84"	2134	463	210.0	6
CBH2496SE-BS*	24"	610	96"	2438	529	240.0	6
CBH24120SE-BS*	24"	610	120"	3048	660	299.4	6
CBH3036SE-BS	30"	762	36"	914	207	93.9	4
CBH3048SE-BS	30"	762	48"	1219	280	127.0	4
CBH3060SE-BS	30"	762	60"	1524	348	157.9	4
CBH3072SE-BS	30"	762	72"	1829	417	189.2	4
CBH3084SE-BS*	30"	762	84"	2134	486	220.5	6
CBH3096SE-BS*	30"	762	96"	2438	555	251.8	6
CBH30120SE-BS*	30"	762	120"	3048	693	314.4	6

* Note: Worktables 84" (2134mm) and longer have two sets of doors.

EAGLE GROUP
 100 Industrial Boulevard, Clayton, DE 19938-8903 USA
 Phone: 302-653-3000 or 800-441-8440 • Fax: 302-653-2065
 www.eaglegrp.com • www.eaglehmc.com

Printed in U.S.A.
 ©2023 by Eagle Group

Rev. 11/23

Spec sheets available for viewing, printing or downloading from our online literature library at our websites

Although every attempt has been made to ensure the accuracy of the information provided, we cannot be held responsible for typographical or printing errors. Information and specifications are subject to change without notice. Please confirm at time of order.