



Profit from the Eagle Advantage®

Specification Sheet

Short Form Specifications

Eagle Mobile Mixer Stand, model _____ . Top to be 14 gauge 300 series stainless steel with no-drip counter top edge. Constructed with uni-lok® patented gusset system, with the gussets recessed into the hat channels to reduce lateral movement. Stainless steel pan rack slides hold six 18" x 26" bun pans. Galvanized or stainless steel tubular base: 1 1/2" O.D. tubular legs with 1 1/2" O.D. tubular cross rails, and 4" swivel casters—two with brake.

Eagle Mobile Equipment Stand, model MET2430S. Top to be 14 gauge 300 series stainless steel with no-drip counter top edge. Constructed with uni-lok® patented gusset system, with the gussets recessed into the hat channels to reduce lateral movement. Heavy gauge stainless steel adjustable undershelf, 1" diameter stainless steel handle welded to brackets and stand. 1 1/2" O.D. stainless steel tubular legs and two 4" casters with brake.



mobile mixer stand



mobile equipment stand

Options / Accessories

- Drawers

EAGLE GROUP

100 Industrial Boulevard, Clayton, DE 19938-8903 USA
Phone: 302-653-3000 • 800-441-8440 • Fax: 302-653-2065
www.eaglegrp.com
www.eaglehmc.com

For custom configuration or fabrication needs, contact our SpecFAB® Division.
Phone: 302-653-3000 • Fax: 302-653-2065 • e-mail: quotes@eaglegrp.com

Item No.: _____
Project No.: _____
S.I.S. No.: _____

Mobile Mixer/Equipment Stands

MODELS:

- MMT3030G MMT3036G MET2430S
- MMT3030S MMT3036S

Mobile Mixer Stands

- Uni-lok® gusset system (patent #5,165,349): gusset is recessed into hat channel underside tabletop, reducing lateral movement.
- Highly-polished 14 gauge 300 series stainless steel top with no-drip countertop edge.
- Stainless steel crossbracing on three sides.
- 1 1/2" (41mm)-diameter legs with four 4" (102mm) casters, two with brake.
- Pan rack slides hold six 18" x 26" (457 x 660mm) pans.
- 400 lb. (181.4 kg) total weight capacity - evenly distributed static load.

Mobile Equipment Stand

- Uni-lok® gusset system (patent #5,165,349): gusset is recessed into hat channel underside tabletop, reducing lateral movement.
- Highly-polished 14 gauge 300 series stainless steel top with no-drip countertop edge.
- Stainless steel undershelf.
- 1 1/2" (41mm)-diameter legs with two 4" (102mm) casters with brake.
- 1" (25mm)-diameter stainless steel handle is welded to heavy duty brackets and stand.

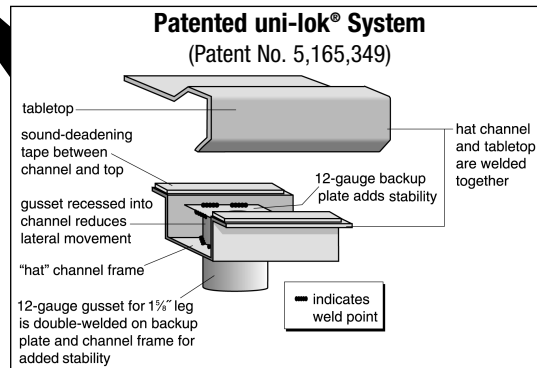

Spec sheets available for viewing, printing or downloading from our online literature library at our websites





Item No.: _____
 Project No.: _____
 S.I.S. No.: _____

Mobile Mixer/Equipment Stands

Mobile Mixer Stands

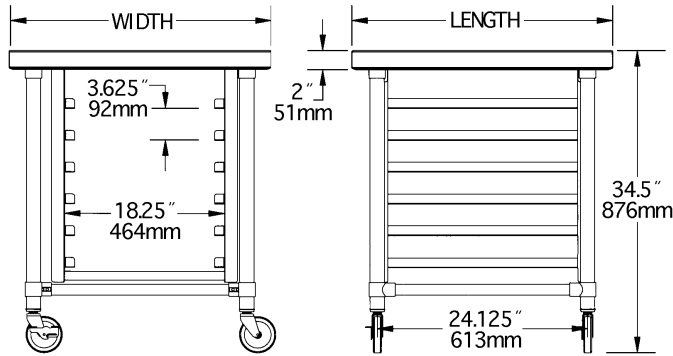

galvanized model #	stainless steel model #	weight		width		length	
		lbs.	kg	in.	mm	in.	mm
MMT3030G	MMT3030S	150	68.0	30"	762	30"	762
MMT3036G	MMT3036S	167	75.8	30"	762	36"	914

Mobile Equipment Stand

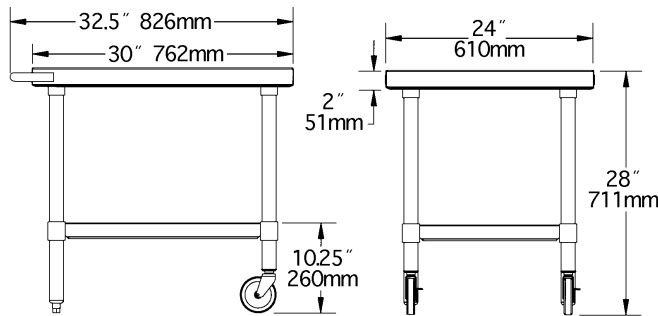

model #	weight		width		length	
	lbs.	kg	in.	mm	in.	mm
MET2430S	47	21.3	24"	610	30"	762

EAGLE GROUP
 100 Industrial Boulevard, Clayton, DE 19938-8903 USA
 Phone: 302-653-3000 or 800-441-8440 • Fax: 302-653-2065
 www.eaglegrp.com • www.eaglemhc.com

Printed in U.S.A.
 ©2023 by Eagle Group
 Rev. 11/23

Spec sheets available for viewing, printing or downloading from our online literature library at our websites

Although every attempt has been made to ensure the accuracy of the information provided, we cannot be held responsible for typographical or printing errors. Information and specifications are subject to change without notice. Please confirm at time of order.