



Profit from the Eagle Advantage®

# Specification Sheet

## Short Form Specifications

Eagle AdjusTable® Work Surface System with Overhead System, model \_\_\_\_\_. Heavy gauge brushed stainless steel top with choice of base combination: one wire undershelf and one C-frame or H-frame, or two C-frames or H-frames. Systems that offer 12"-wide (chrome, stainless steel) cantilevered overshelves are combined with two 33" front posts and two 63" rear posts. Systems that offer 14"-wide (chrome, stainless steel) wire overshelves are combined with two 33" front posts, two 63" rear posts, and two 29" front posts for wire overshelves. Wire overshelves and undershelves feature patented QuadTruss® design (patent #5,390,803).



AdjusTable® with Cantilevered Overhead System and undershelf/C-frame base



AdjusTable® with Wire Overshelf System and C-frame bases

### Options / Accessories

- Drawers
- Keyboard stations
- Reel holders\*\*
- Lock
- Add'l undershelves
- Bench power centers\*\*
- Casters
- Bin holders\*\*

\*\* See spec sheet #EG07.13B for these options.

### EAGLE GROUP

100 Industrial Boulevard, Clayton, DE 19938-8903 USA  
Phone: 302-653-3000 • 800-441-8440 • Fax: 302-653-2065  
www.eaglegrp.com  
www.eaglegrpnews.com  
www.eaglemh.com

For custom configuration or fabrication needs, contact our SpecFAB® Division.  
Phone: 302-653-3000 • Fax: 302-653-2065 • e-mail: quotes@eaglegrp.com

Item No.: \_\_\_\_\_  
 Project No.: \_\_\_\_\_  
 S.I.S. No.: \_\_\_\_\_

## AdjusTable® Work Surface System with Overhead System

### MODELS:

- \*2436\*
- \*2448\*
- \*2460\*
- \*3036\*
- \*3048\*
- \*3060\*
- \*3636\*
- \*3648\*
- \*3660\*

\* See charts on next two pages for complete model numbers.

### Features on all systems

- Solid stainless steel work surface with brushed finish.
- All work surface tabletops feature hat channel underneath for added strength.
- All posts are numbered in 1" (25mm) increments for flexible and level positioning of the base that you choose. Available in chrome or stainless steel finish.
- Base combination available with or without wire undershelf, with chrome or stainless steel H-frame(s) or C-frame(s).
- An almost unlimited number of custom configurations can be created by adding undershelves.
- 34½" (876mm) working height.

### AdjusTable® with Cantilevered Overhead System

- Two 33" (838mm) front posts.
- Two 63" (1600mm) rear posts.
- Two 12" (305mm)-wide chrome or stainless steel cantilevered shelves mount to rear posts.

### AdjusTable® with Wire Overhead System

- Two 33" (838mm) front posts.
- Two 63" (1600mm) rear posts.
- Two 29" (737mm) front posts for wire overshelves.
- Two 14" (356mm)-wide chrome or stainless steel wire overshelves mount to rear posts and to 29" (737mm) posts.

### Certifications / Approvals





Profit from the Eagle Advantage®

## Adjustable® Work Surface Systems with Cantilevered Overhead System



### “OAC” Series Tables

Brushed 16/304 stainless steel solid top and chrome cantilevered overshelves, with choice of:

- Two knocked down chrome C-frames
- Two knocked down chrome H-frames
- One chrome C-frame and one chrome wire undershelf
- One chrome H-frame and one chrome wire undershelf
- Two chrome wire undershelves

length		weight		WITH TWO C-FRAMES	WITH TWO H-FRAMES	WITH ONE C-FRAME AND ONE WIRE SHELF	WITH ONE H-FRAME AND ONE WIRE SHELF	WITH TWO WIRE SHELVES
in.	mm	lb.	kg	model #	model #	model #	model #	model #
24" x 36"	610 x 914	65	29.5	OAC2436T-2C	OAC2436T-2H	OAC2436T-1C-1W	OAC2436T-1H-1W	OAC2436T-2W
24" x 48"	610 x 1219	81	36.7	OAC2448T-2C	OAC2448T-2H	OAC2448T-1C-1W	OAC2448T-1H-1W	OAC2448T-2W
24" x 60"	610 x 1524	97	44.0	OAC2460T-2C	OAC2460T-2H	OAC2460T-1C-1W	OAC2460T-1H-1W	OAC2460T-2W
30" x 36"	762 x 914	75	34.0	OAC3036T-2C	OAC3036T-2H	OAC3036T-1C-1W	OAC3036T-1H-1W	OAC3036T-2W
30" x 48"	762 x 1219	94	42.6	OAC3048T-2C	OAC3048T-2H	OAC3048T-1C-1W	OAC3048T-1H-1W	OAC3048T-2W
30" x 60"	762 x 1524	113	51.3	OAC3060T-2C	OAC3060T-2H	OAC3060T-1C-1W	OAC3060T-1H-1W	OAC3060T-2W
36" x 36"	914 x 914	85	38.6	OAC3636T-2C	OAC3636T-2H	OAC3636T-1C-1W	OAC3636T-1H-1W	OAC3636T-2W
36" x 48"	914 x 1219	108	49.0	OAC3648T-2C	OAC3648T-2H	OAC3648T-1C-1W	OAC3648T-1H-1W	OAC3648T-2W
36" x 60"	914 x 1524	131	59.4	OAC3660T-2C	OAC3660T-2H	OAC3660T-1C-1W	OAC3660T-1H-1W	OAC3660T-2W

### “OAS” Series Tables

Brushed 16/304 stainless steel solid top and stainless steel cantilevered overshelves, with choice of:

- Two knocked down stainless steel C-frames
- Two knocked down stainless steel H-frames
- One stainless steel C-frame and one stainless steel wire undershelf
- One stainless steel H-frame and one chrome wire undershelf
- Two stainless steel wire undershelves

length		weight		WITH TWO C-FRAMES	WITH TWO H-FRAMES	WITH ONE C-FRAME AND ONE WIRE SHELF	WITH ONE H-FRAME AND ONE WIRE SHELF	WITH TWO WIRE SHELVES
in.	mm	lb.	kg	model #	model #	model #	model #	model #
24" x 36"	610 x 914	65	29.5	OAS2436T-2C	OAS2436T-2H	OAS2436T-1C-1W	OAS2436T-1H-1W	OAS2436T-2W
24" x 48"	610 x 1219	81	36.7	OAS2448T-2C	OAS2448T-2H	OAS2448T-1C-1W	OAS2448T-1H-1W	OAS2448T-2W
24" x 60"	610 x 1524	97	44.0	OAS2460T-2C	OAS2460T-2H	OAS2460T-1C-1W	OAS2460T-1H-1W	OAS2460T-2W
30" x 36"	762 x 914	75	34.0	OAS3036T-2C	OAS3036T-2H	OAS3036T-1C-1W	OAS3036T-1H-1W	OAS3036T-2W
30" x 48"	762 x 1219	94	42.6	OAS3048T-2C	OAS3048T-2H	OAS3048T-1C-1W	OAS3048T-1H-1W	OAS3048T-2W
30" x 60"	762 x 1524	113	51.3	OAS3060T-2C	OAS3060T-2H	OAS3060T-1C-1W	OAS3060T-1H-1W	OAS3060T-2W
36" x 36"	914 x 914	85	38.6	OAS3636T-2C	OAS3636T-2H	OAS3636T-1C-1W	OAS3636T-1H-1W	OAS3636T-2W
36" x 48"	914 x 1219	108	49.0	OAS3648T-2C	OAS3648T-2H	OAS3648T-1C-1W	OAS3648T-1H-1W	OAS3648T-2W
36" x 60"	914 x 1524	131	59.4	OAS3660T-2C	OAS3660T-2H	OAS3660T-1C-1W	OAS3660T-1H-1W	OAS3660T-2W

Spec sheets available for viewing, printing or downloading from our online literature library at our websites

## Adjustable® Work Surface Systems with Wire Overshelf System



### “WOAC” Series Tables

Brushed 16/304 stainless steel solid top and chrome overshelves, with choice of:

- Two knocked down chrome C-frames
- Two knocked down chrome H-frames
- One chrome C-frame and one chrome wire undershelf
- One chrome H-frame and one chrome wire undershelf
- Two chrome wire undershelves

length		weight		WITH TWO C-FRAMES	WITH TWO H-FRAMES	WITH ONE C-FRAME AND ONE WIRE SHELF	WITH ONE H-FRAME AND ONE WIRE SHELF	WITH TWO WIRE SHELVES
in.	mm	lb.	kg	model #	model #	model #	model #	model #
24" x 36"	610 x 914	65	29.5	WOAC2436T-2C	WOAC2436T-2H	WOAC2436T-1C-1W	WOAC2436T-1H-1W	WOAC2436T-2W
24" x 48"	610 x 1219	81	36.7	WOAC2448T-2C	WOAC2448T-2H	WOAC2448T-1C-1W	WOAC2448T-1H-1W	WOAC2448T-2W
24" x 60"	610 x 1524	97	44.0	WOAC2460T-2C	WOAC2460T-2H	WOAC2460T-1C-1W	WOAC2460T-1H-1W	WOAC2460T-2W
30" x 36"	762 x 914	75	34.0	WOAC3036T-2C	WOAC3036T-2H	WOAC3036T-1C-1W	WOAC3036T-1H-1W	WOAC3036T-2W
30" x 48"	762 x 1219	94	42.6	WOAC3048T-2C	WOAC3048T-2H	WOAC3048T-1C-1W	WOAC3048T-1H-1W	WOAC3048T-2W
30" x 60"	762 x 1524	113	51.3	WOAC3060T-2C	WOAC3060T-2H	WOAC3060T-1C-1W	WOAC3060T-1H-1W	WOAC3060T-2W
36" x 36"	914 x 914	85	38.6	WOAC3636T-2C	WOAC3636T-2H	WOAC3636T-1C-1W	WOAC3636T-1H-1W	WOAC3636T-2W
36" x 48"	914 x 1219	108	49.0	WOAC3648T-2C	WOAC3648T-2H	WOAC3648T-1C-1W	WOAC3648T-1H-1W	WOAC3648T-2W
36" x 60"	914 x 1524	131	59.4	WOAC3660T-2C	WOAC3660T-2H	WOAC3660T-1C-1W	WOAC3660T-1H-1W	WOAC3660T-2W

### “WOAS” Series Tables

Brushed 16/304 stainless steel solid top and stainless steel overshelves, with choice of:

- Two knocked down stainless steel C-frames
- Two knocked down stainless steel H-frames
- One stainless steel C-frame and one stainless steel wire undershelf
- One stainless steel H-frame and one chrome wire undershelf
- Two stainless steel wire undershelves

length		weight		WITH TWO C-FRAMES	WITH TWO H-FRAMES	WITH ONE C-FRAME AND ONE WIRE SHELF	WITH ONE H-FRAME AND ONE WIRE SHELF	WITH TWO WIRE SHELVES
in.	mm	lb.	kg	model #	model #	model #	model #	model #
24" x 36"	610 x 914	65	29.5	WOAS2436T-2C	WOAS2436T-2H	WOAS2436T-1C-1W	WOAS2436T-1H-1W	WOAS2436T-2W
24" x 48"	610 x 1219	81	36.7	WOAS2448T-2C	WOAS2448T-2H	WOAS2448T-1C-1W	WOAS2448T-1H-1W	WOAS2448T-2W
24" x 60"	610 x 1524	97	44.0	WOAS2460T-2C	WOAS2460T-2H	WOAS2460T-1C-1W	WOAS2460T-1H-1W	WOAS2460T-2W
30" x 36"	762 x 914	75	34.0	WOAS3036T-2C	WOAS3036T-2H	WOAS3036T-1C-1W	WOAS3036T-1H-1W	WOAS3036T-2W
30" x 48"	762 x 1219	94	42.6	WOAS3048T-2C	WOAS3048T-2H	WOAS3048T-1C-1W	WOAS3048T-1H-1W	WOAS3048T-2W
30" x 60"	762 x 1524	113	51.3	WOAS3060T-2C	WOAS3060T-2H	WOAS3060T-1C-1W	WOAS3060T-1H-1W	WOAS3060T-2W
36" x 36"	914 x 914	85	38.6	WOAS3636T-2C	WOAS3636T-2H	WOAS3636T-1C-1W	WOAS3636T-1H-1W	WOAS3636T-2W
36" x 48"	914 x 1219	108	49.0	WOAS3648T-2C	WOAS3648T-2H	WOAS3648T-1C-1W	WOAS3648T-1H-1W	WOAS3648T-2W
36" x 60"	914 x 1524	131	59.4	WOAS3660T-2C	WOAS3660T-2H	WOAS3660T-1C-1W	WOAS3660T-1H-1W	WOAS3660T-2W



Item No.:	_____
Project No.:	_____
S.I.S. No.:	_____

## Adjustable® Work Surface Systems with Overhead System

### adjustable® with Cantilevered Overhead System

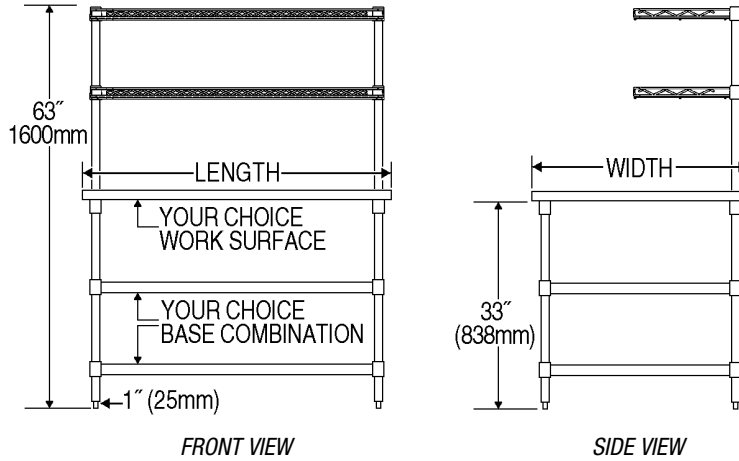

### adjustable® with Wire Overshelf System

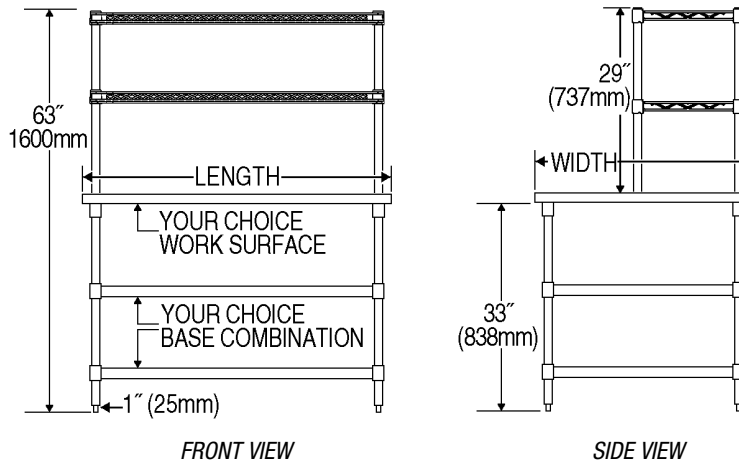

**EAGLE GROUP**  
 100 Industrial Boulevard, Clayton, DE 19938-8903 USA  
 Phone: 302-653-3000 or 800-441-8440 • Fax: 302-653-2065  
 www.eaglegrp.com • www.eaglegrpnews.com • www.eaglehmc.com

Printed in U.S.A.  
 ©2023 by Eagle Group  
 Rev. 07/23

Spec sheets available for viewing, printing or downloading from our online literature library at our websites

Although every attempt has been made to ensure the accuracy of the information provided, we cannot be held responsible for typographical or printing errors. Information and specifications are subject to change without notice. Please confirm at time of order.