



Profit from the Eagle Advantage®

Specification Sheet

Short Form Specifications

Models designed to facilitate 7" and 13"-15" reels. Footprint of 18" width x 36" length, with EAGLEbrite® zinc plating. Shelf capacity of (78) 7" reels and (15) 13"-15" reels. 9 gauge divider mat wires. Shelf adjustable on 1" increments.

Item No.:	_____
Project No.:	_____
S.I.S. No.:	_____

Reel Shelves

MODELS:

- R1836Z-7
- R1836Z-13

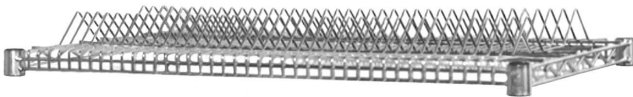

#R1836Z-7 reel shelf

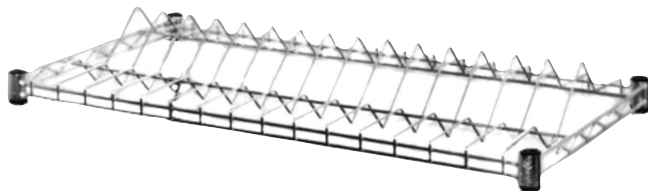

#R1836Z-13 reel shelf

Design and Construction Features

- Two models available for holding either (78) 7" (178mm)-diameter reels or (15) 13" to 15" (330 to 381mm)-diameter reels.
- 9 gauge wire for the mat and 6 gauge wire for the cradle and trusses.
- EAGLEbrite® zinc-plated shelving.
- Both shelves feature 36" (914mm) length and 18" (457mm) width.

EAGLE GROUP

100 Industrial Boulevard, Clayton, DE 19938-8903 USA

Phone: 302-653-3000 • 800-441-8440 • Fax: 302-653-2065

www.eaglegrp.com

www.eaglemhc.com

For custom configuration or fabrication needs, contact our SpecFAB® Division.

Phone: 302-653-3000 • Fax: 302-653-2065 • e-mail: quotes@eaglegrp.com

EG07.06 Rev. 10/23

Spec sheets available for viewing, printing or downloading from our online literature library at our websites

Eagle Foodservice Equipment, Eagle MHC, and SpecFAB® are divisions of Eagle Group. ©2023 by the Eagle Group



Item No.: _____
 Project No.: _____
 S.I.S. No.: _____

Reel Shelves

Model #R1836Z-7

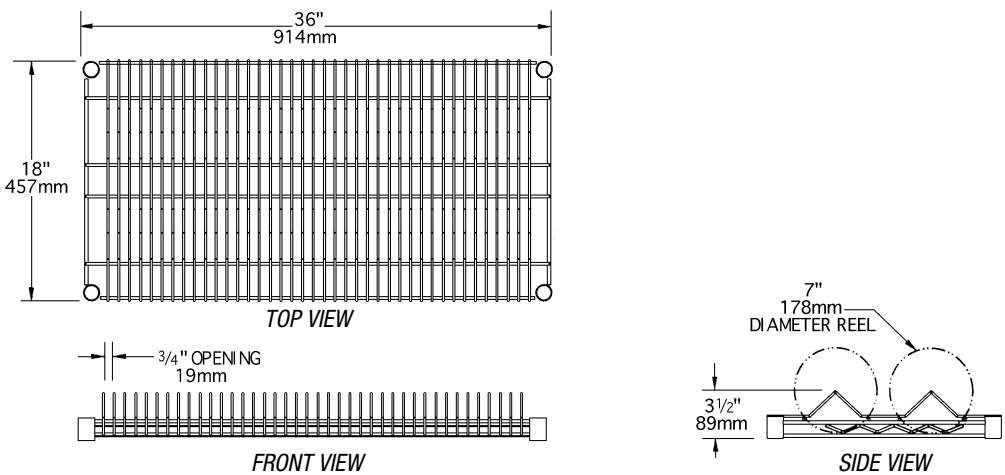

model #	width		length		weight		open space for each reel		capacity
	in.	mm	in.	mm	lbs.	kg	in.	mm	
R1836Z-7	18"	457	36"	914	10	4.5	3/4"	19	(78) 7"-diameter reels

Model #R1836Z-13

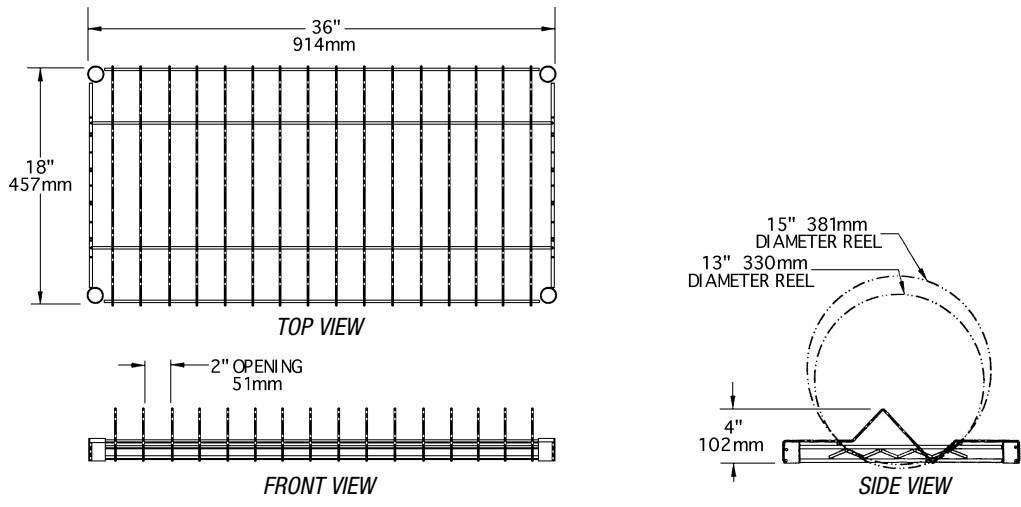

model #	width		length		weight		open space for each reel		capacity
	in.	mm	in.	mm	lbs.	kg	in.	mm	
R1836Z-13	18"	457	36"	914	9	4.1	2"	51	(15) 13"- to 15"-diameter reels

EAGLE GROUP
 100 Industrial Boulevard, Clayton, DE 19938-8903 USA
 Phone: 302-653-3000 or 800-441-8440 • Fax: 302-653-2065
 www.eaglegrp.com • www.eaglehmc.com

Printed in U.S.A.
 ©2023 by Eagle Group
 Rev. 10/23

Spec sheets available for viewing, printing or downloading from our online literature library at our websites

Although every attempt has been made to ensure the accuracy of the information provided, we cannot be held responsible for typographical or printing errors. Information and specifications are subject to change without notice. Please confirm at time of order.