



Profit from the Eagle Advantage®

# Specification Sheet

## Short Form Specifications

Up to 30° variable angle wire shelf with 3½" upturn. Footprint of 36" depth by 36", 48", and 60" length. Three shelves per unit with 42" worksurface, adjustable on 1" centers. Mobile unit includes 5" resilient casters—two swivel and two with brake. EAGLEbrite® zinc plating.



model #M3648Z-3

### Options / Accessories

- Aluminum split sleeves
- Anti-static drag chain
- Polyurethane casters

### EAGLE GROUP

100 Industrial Boulevard, Clayton, DE 19938-8903 USA  
 Phone: 302-653-3000 • 800-441-8440 • Fax: 302-653-2065  
[www.eaglegrp.com](http://www.eaglegrp.com)  
[www.eaglegrpnews.com](http://www.eaglegrpnews.com)  
[www.eaglemhc.com](http://www.eaglemhc.com)

For custom configuration or fabrication needs, contact our **SpecFAB® Division**.  
 Phone: 302-653-3000 • Fax: 302-653-2065 • e-mail: [quotes@eaglegrp.com](mailto:quotes@eaglegrp.com)

Item No.:	_____
Project No.:	_____
S.I.S. No.:	_____

## Gravity Flow Line Feed Carts

### MODELS:

- |                                    |                                  |                                  |
|------------------------------------|----------------------------------|----------------------------------|
| <input type="checkbox"/> SM3636Z-3 | <input type="checkbox"/> M3636Z  | <input type="checkbox"/> A215538 |
| <input type="checkbox"/> SM3648Z-3 | <input type="checkbox"/> M3648Z  | <input type="checkbox"/> A215539 |
| <input type="checkbox"/> SM3660Z-3 | <input type="checkbox"/> M3660Z  | <input type="checkbox"/> A215541 |
| <input type="checkbox"/> M3636Z-3  | <input type="checkbox"/> A215543 | <input type="checkbox"/> A215532 |
| <input type="checkbox"/> M3648Z-3  | <input type="checkbox"/> A215544 | <input type="checkbox"/> A215534 |
| <input type="checkbox"/> M3660Z-3  | <input type="checkbox"/> A215546 | <input type="checkbox"/> A215536 |

### Design and Construction Features

- Available in three lengths - 36" (914mm), 48" (1219mm) and 60" (1524mm).
- All components available by the piece, allowing custom configurations.
- Shelf design allows for variable angles, and creates a visual advantage of the inventory.
- Shelf dimension provides adequate space for double kitting, which allows for more inventory where needed.
- Angled shelves provide ergonomic assistance in picking operations.
- Optional aluminum split sleeves and drag chain are available for conductivity.
- Optional polyurethane or vibration dampening casters are available.
- Flexibility to adjust shelves on 1" (25mm) increments and the slope of the shelf.
- Maximum shelf slope of 30°.
- Open-wire construction for high visibility of merchandise.
- 63" (1600mm) height stationary units include leveling feet.
- 69" (1753mm) height mobile units include 5" x 1¼" (127 x 32mm) standard resilient swivel casters, two with brake—each with a weight capacity of 300 lbs. (136.1 kg). Additional caster sizes available.



EG07.03 Rev. 07/23

Spec sheets available for viewing, printing or downloading from our online literature library at our websites

Eagle Foodservice Equipment, Eagle MHC, and SpecFAB® are divisions of Eagle Group. ©2023 by the Eagle Group



Profit from the Eagle Advantage®

Item No.: \_\_\_\_\_  
 Project No.: \_\_\_\_\_  
 S.I.S. No.: \_\_\_\_\_

## Gravity Flow Line Feed Carts

### Stationary Units

EAGLEbrite® model #	length		weight	
	in.	mm	lbs.	kg
SM3636Z-3	36"	914	93	42.2
SM3648Z-3	48"	1219	114	51.7
SM3660Z-3	60"	1524	144	65.3

### Mobile Units

Casters included.

EAGLEbrite® model #	length		weight	
	in.	mm	lbs.	kg
M3636Z-3	36"	914	93	42.2
M3648Z-3	48"	1219	114	51.7
M3660Z-3	60"	1524	144	65.3

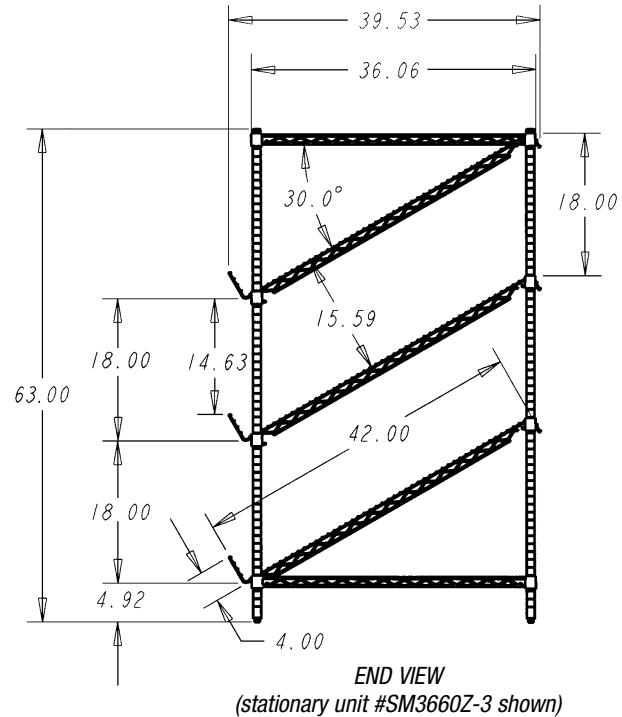

## Additional/Replacement Components

### Angled Shelves

Hanger rails included.

EAGLEbrite® model #	length		weight	
	in.	mm	lbs.	kg
M3636Z	36"	914	26	11.8
M3648Z	48"	1219	32	14.5
M3660Z	60"	1524	40	18.1

### 4-Sided Truss Snares

EAGLEbrite® model #	width		length		weight	
	in.	mm	in.	mm	lbs.	kg
A215532	36"	914	36"	914	9	4.1
A215534	36"	914	48"	1219	12	5.4
A215536	36"	914	60"	1524	15	6.8

### Side-to-Side Hanger Rails

Hanger rails included.

EAGLEbrite® model #	length		weight	
	in.	mm	lbs.	kg
A215543	36"	914	3	1.4
A215544	48"	1219	4	1.8
A215546	60"	1524	5	2.3

### 3-Sided Truss Snares

EAGLEbrite® model #	width		length		weight	
	in.	mm	in.	mm	lbs.	kg
A215538	36"	914	36"	914	7	3.2
A215539	36"	914	48"	1219	10	4.5
A215541	36"	914	60"	1524	12	5.4

### EAGLE GROUP

100 Industrial Boulevard, Clayton, DE 19938-8903 USA

Phone: 302-653-3000 or 800-441-8440 • Fax: 302-653-2065

www.eaglegrp.com • www.eaglegrpnews.com • www.eaglehmc.com

Printed in U.S.A.  
 ©2023 by Eagle Group

Rev. 07/23

Spec sheets available for viewing, printing or downloading from our online literature library at our websites

Although every attempt has been made to ensure the accuracy of the information provided, we cannot be held responsible for typographical or printing errors. Information and specifications are subject to change without notice. Please confirm at time of order.