



Profit from the Eagle Advantage®

Specification Sheet

Short Form Specifications

Angled wire shelf with 3½" upturn, zinc-plated. Overall height of 39", with front working height of 30". Length dimension of 24", 36", 48", or 60". 18" width. 5" resilient casters, two with brake. Standard wire undershelf.



48" (1219mm)-long benchside tote box carrier shown with tote boxes

Options / Accessories

- Shelf dividers
- Aluminum split sleeves
- Anti-static drag chain
- Tote boxes

EAGLE GROUP

100 Industrial Boulevard, Clayton, DE 19938-8903 USA
 Phone: 302-653-3000 • 800-441-8440 • Fax: 302-653-2065
www.eaglegrp.com
www.eaglegrpnews.com
www.eaglemhc.com

For custom configuration or fabrication needs, contact our **SpecFAB® Division**.
 Phone: 302-653-3000 • Fax: 302-653-2065 • e-mail: quotes@eaglegrp.com

Item No.:	_____
Project No.:	_____
S.I.S. No.:	_____

Benchside Tote Box Carriers

MODELS:

- 1824BTZ
- 1836BTZ
- 1848BTZ
- 1860BTZ

Design and Construction Features

- Ergonomically designed for repetitive pick-and-place activity.
- Features angled shelf with built-in ledge and flat undershelf.
- All shelves are open wire construction, reducing moisture and dust build-up.
- Two 24" (610mm) zinc-plated front posts.
- Two 33" (838mm) zinc-plated rear posts.
- Four 5" (127mm)-diameter swivel casters with resilient tread (two with brake).
- One 18" (457mm)-wide wire angled shelf.
- One 18" (457mm)-wide wire undershelf.
- One 18" (457mm)-wide 3-sided truss frame.
- One full-length hanger rail.
- 30" (762mm) front height.
- 39" (991mm) rear height.
- Shipped knocked-down.



EG07.02 Rev. 07/23

Spec sheets available for viewing, printing or downloading from our online literature library at our websites

Eagle Foodservice Equipment, Eagle MHC, and SpecFAB® are divisions of Eagle Group. ©2023 by the Eagle Group



Item No.:	_____
Project No.:	_____
S.I.S. No.:	_____

Benchside Tote Box Carriers

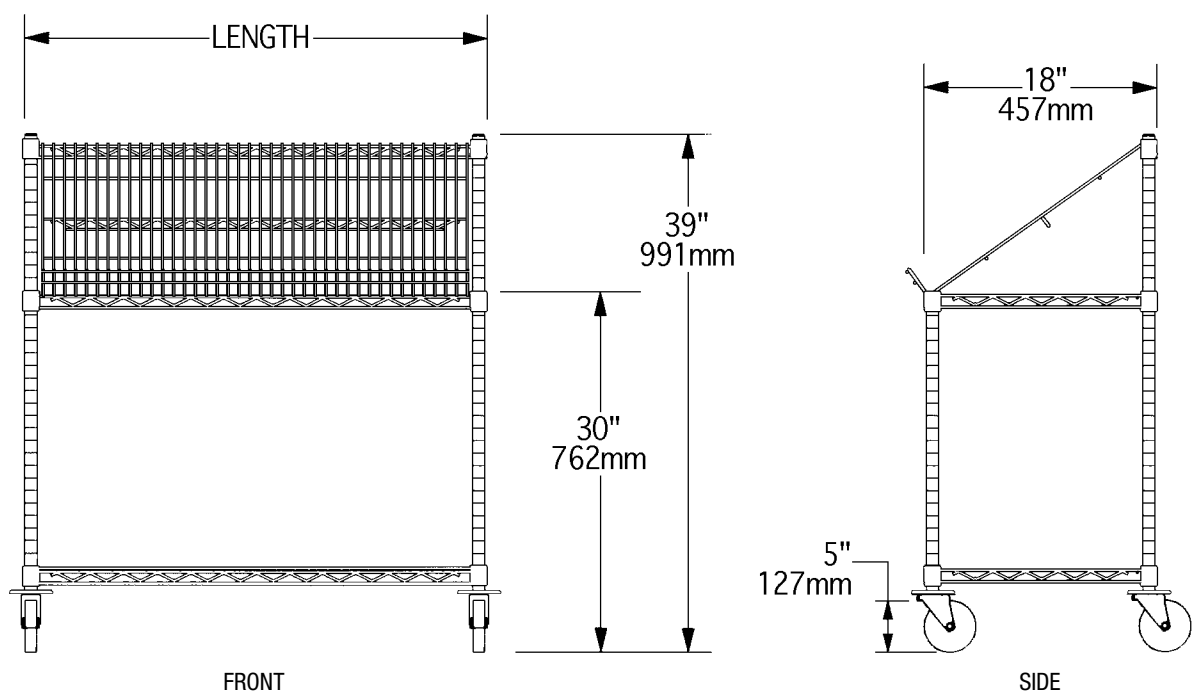

model #	width		length		front height		rear height		weight		caster type
	in.	mm	in.	mm	in.	mm	in.	mm	lbs.	kg	
1824BTZ	18"	457	24"	610	30"	762	39"	991	50	22.7	5" resilient swivel (two w/brake)
1836BTZ	18"	457	36"	914	30"	762	39"	991	55	24.9	5" resilient swivel (two w/brake)
1848BTZ	18"	457	48"	1219	30"	762	39"	991	60	27.2	5" resilient swivel (two w/brake)
1860BTZ	18"	457	60"	1524	30"	762	39"	991	65	29.5	5" resilient swivel (two w/brake)

EAGLE GROUP
 100 Industrial Boulevard, Clayton, DE 19938-8903 USA
 Phone: 302-653-3000 or 800-441-8440 • Fax: 302-653-2065
 www.eaglegrp.com • www.eaglegrpnews.com • www.eaglehmc.com

Printed in U.S.A.
 ©2023 by Eagle Group
 Rev. 07/23

Spec sheets available for viewing, printing or downloading from our online literature library at our websites

Although every attempt has been made to ensure the accuracy of the information provided, we cannot be held responsible for typographical or printing errors. Information and specifications are subject to change without notice. Please confirm at time of order.