



Profit from the Eagle Advantage®

Specification Sheet

Short Form Specifications

Cart dimension are 24" wide x 36" long x 36" or 48" tall. 16 gauge 300 series stainless steel top with two adjustable 18 gauge solid shelves. 5"-diameter polyurethane swivel casters, two with brake.



Steril-Eze® horizontal open surgical case cart

Options / Accessories

- Drawer
- Additional shelves

EAGLE GROUP

100 Industrial Boulevard, Clayton, DE 19938-8903 USA
 Phone: 302-653-3000 • 800-441-8440 • Fax: 302-653-2065
www.eaglegrp.com
www.eaglegrpnews.com
www.eaglemhc.com

For custom configuration or fabrication needs, contact our **SpecFAB® Division**.
 Phone: 302-653-3000 • Fax: 302-653-2065 • e-mail: quotes@eaglegrp.com

Item No.:	_____
Project No.:	_____
S.I.S. No.:	_____

Steril-Eze® Horizontal Open Surgical Case Carts

MODELS:

- OSCC2436**
- OSCC2448**
- A204178**

Design and Construction Features

- Designed with cleanliness in mind. All components have safety edges and are free of bacteria-gathering crevices. Center shelf removable for ease of cleaning. Cart is washable.
- Type 304 stainless steel.
- Top is 16 gauge stainless steel.
- Center shelf constructed with hemmed safety edges. Shelves are adjustable. Additional solid shelves available.
- 5" (127mm) casters are chrome-plated with polyurethane tread. Other caster combinations are available on request.
- Stainless steel drawers for equipment storage can be added.





Item No.: _____
 Project No.: _____
 S.I.S. No.: _____

Steril-Eze® Horizontal Open Surgical Case Carts

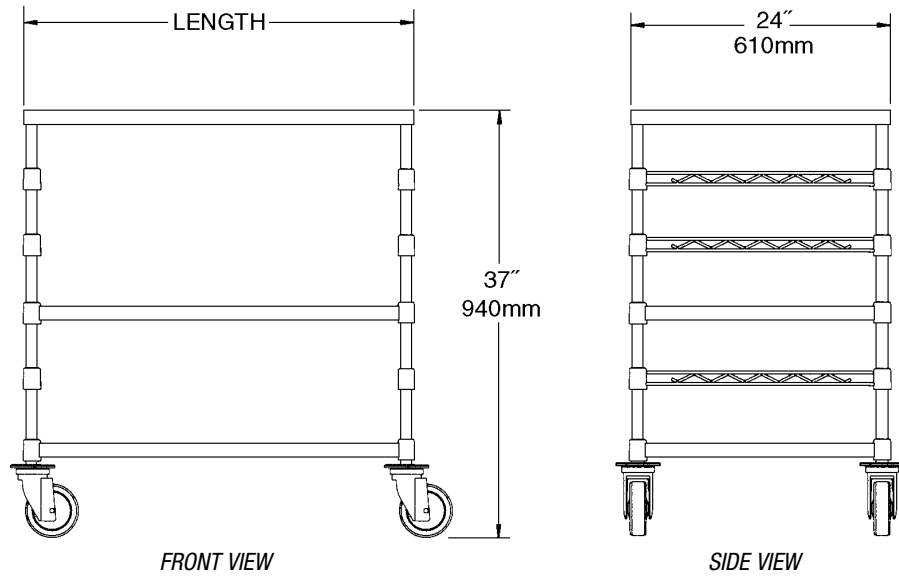

model #	width		length		height		weight	
	in.	mm	in.	mm	in.	mm	lbs.	kg
OSCC2436	24"	610	36"	914	36"	914	89	40.4
OSCC2448	24"	610	48"	1219	36"	914	118	53.5

Optional Drawer

model #	width		length		height		weight	
	in.	mm	in.	mm	in.	mm	lbs.	kg
A204178	12"	305	20"	508	4"	102	6	2.7

EAGLE GROUP
 100 Industrial Boulevard, Clayton, DE 19938-8903 USA
 Phone: 302-653-3000 or 800-441-8440 • Fax: 302-653-2065
 www.eaglegrp.com • www.eaglegrpnews.com • www.eaglemhc.com

Printed in U.S.A.
 ©2023 by Eagle Group
 Rev. 07/23

Spec sheets available for viewing, printing or downloading from our online literature library at our websites

Although every attempt has been made to ensure the accuracy of the information provided, we cannot be held responsible for typographical or printing errors. Information and specifications are subject to change without notice. Please confirm at time of order.