



Profit from the Eagle Advantage®

Specification Sheet

Short Form Specifications

Overall dimension of 20" wide x 27" long x 40" tall. Top and bottom PVC-coated tank holding grids are built on 4½" centers, to store up to 12 cylinders. Two utility handles and wire shelf base are chrome-plated. 5"-diameter conductive casters, two with brake.



Item No.:	_____
Project No.:	_____
S.I.S. No.:	_____

Inhalation Therapy Cart

MODELS:

GCC1

Design and Construction Features

- QuadTruss® design (patent #5,390,803) makes shelves up to 20% stronger and provides a retaining ledge for increased storage stability and product retention.
- Top and bottom inserts, which snap over the top and bottom frame, are PVC-coated for noise and vibration reduction.
- Chrome finished handles, frames, and bottom shelf.
- Aluminum split sleeves and conductive casters reduce static electrical charge.
- Each PVC-coated insert has 12 compartments, each measuring 4½" (114mm) square—any combination of gas cylinders can be stored.
- UL-recognized 5" (127mm)-diameter conductive casters—two with brake.
- Easy assembly and adjusted without the use of tools.
- Cart design conforms to NFPA-99.

EAGLE GROUP

100 Industrial Boulevard, Clayton, DE 19938-8903 USA

Phone: 302-653-3000 • 800-441-8440 • Fax: 302-653-2065

www.eaglegrp.com

www.eaglegrpnews.com

www.eaglemhc.com

For custom configuration or fabrication needs, contact our **SpecFAB® Division**.

Phone: 302-653-3000 • Fax: 302-653-2065 • e-mail: quotes@eaglegrp.com



EG05.12 Rev. 07/23

Spec sheets available for viewing, printing or downloading from our online literature library at our websites

Eagle Foodservice Equipment, Eagle MHC, and SpecFAB® are divisions of Eagle Group. ©2023 by the Eagle Group



Item No.: _____
 Project No.: _____
 S.I.S. No.: _____

Inhalation Therapy Cart

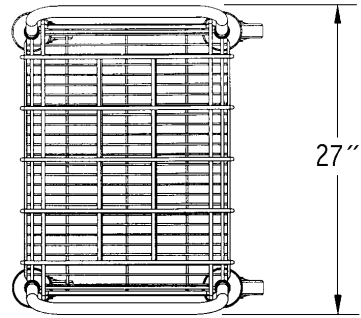

TOP VIEW

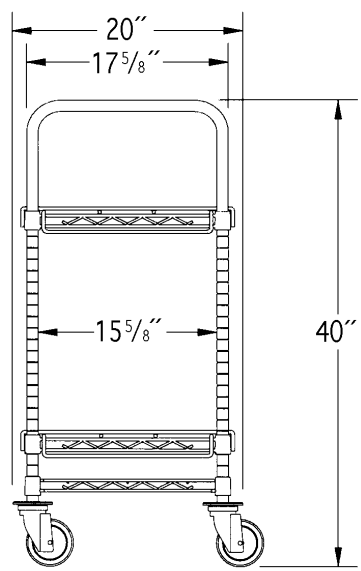

END VIEW

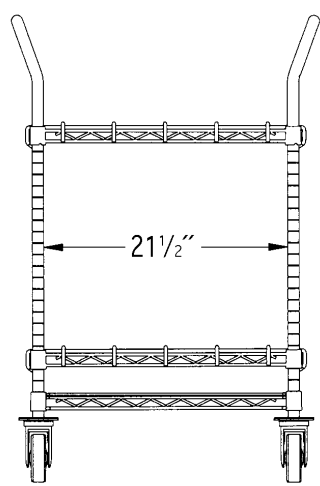

SIDE VIEW

model #	width		length		height		weight	
	in.	mm	in.	mm	in.	mm	lbs.	kg
GCC1	20"	508	27"	686	40"	1016	41	19

EAGLE GROUP
 100 Industrial Boulevard, Clayton, DE 19938-8903 USA
 Phone: 302-653-3000 or 800-441-8440 • Fax: 302-653-2065
 www.eaglegrp.com • www.eaglegrpnews.com • www.eaglemh.com

Printed in U.S.A.
 ©2023 by Eagle Group
 Rev. 07/23

Spec sheets available for viewing, printing or downloading from our online literature library at our websites

Although every attempt has been made to ensure the accuracy of the information provided, we cannot be held responsible for typographical or printing errors. Information and specifications are subject to change without notice. Please confirm at time of order.