



Profit from the Eagle Advantage®

# Specification Sheet

## Short Form Specifications

Chrome-plated 24" wide by 48" or 60" lengths. Four support bars with a wire shelf at the base and a three-sided channel frame at the mid height and top. 5" diameter polyurethane swivel casters.



#SWC2460C sterile wrap cart

### Options / Accessories

- Cart cover
- Additional support bars
- Ledges
- Dividers
- Plastic shelf markers

### EAGLE GROUP

100 Industrial Boulevard, Clayton, DE 19938-8903 USA  
 Phone: 302-653-3000 • 800-441-8440 • Fax: 302-653-2065  
[www.eaglegrp.com](http://www.eaglegrp.com)  
[www.eaglegrpnews.com](http://www.eaglegrpnews.com)  
[www.eaglemhc.com](http://www.eaglemhc.com)

For custom configuration or fabrication needs, contact our **SpecFAB® Division**.  
 Phone: 302-653-3000 • Fax: 302-653-2065 • e-mail: [quotes@eaglegrp.com](mailto:quotes@eaglegrp.com)

Item No.: \_\_\_\_\_  
 Project No.: \_\_\_\_\_  
 S.I.S. No.: \_\_\_\_\_

## Sterile Wrap Carts

### MODELS:

- |                                     |                                      |                                      |
|-------------------------------------|--------------------------------------|--------------------------------------|
| <input type="checkbox"/> SWC2448C   | <input type="checkbox"/> CV-63-2448  | <input type="checkbox"/> CVC-63-2448 |
| <input type="checkbox"/> SWC2460C   | <input type="checkbox"/> CV-63-2460  | <input type="checkbox"/> CVC-63-2460 |
| <input type="checkbox"/> CZ-63-2448 | <input type="checkbox"/> CZC-63-2448 | <input type="checkbox"/> SB48        |
| <input type="checkbox"/> CZ-63-2460 | <input type="checkbox"/> CZC-63-2460 | <input type="checkbox"/> SB60        |

### Design and Construction Features

- Sterile Wrap Carts provide a safe and convenient place to hang or store wraps. Most wraps can be hung so that all sizes can be seen or removed at one time. The bottom wire shelf, standard on all units, can be used to hold extra or odd size wraps.
- Carrier assembly, which supports the bars, is adjustable in 1" (25mm) increments along the height of the posts so that it can be positioned at a comfortable level for users, whether seated or standing. The four bars can also be positioned in any of 18 slots along the carrier assembly.
- All models come standard with four square horizontal bars; additional bars can be added as accessories if needed.
- 5" (127mm) swivel casters provide easy maneuverability.
- Available in two lengths: 48" and 60" (1219 and 1524mm). The 60" (1219mm) models will hold wrap up to 54" x 72" (1372 x 1829mm).
- All models are 68" (1727mm) in overall height.
- Units have four 1" (25mm)-diameter posts with grooves numbered in 1" (25mm) increments to ensure fast and level assembly and adjustment.
- 5" (127mm) swivel chrome-plated with polyurethane tread.
- Chrome-plated bottom wire shelf.
- 3-sided chrome-plated top and intermediate channel frames.
- 1" (25mm) chrome-plated support bars.





Item No.: \_\_\_\_\_  
 Project No.: \_\_\_\_\_  
 S.I.S. No.: \_\_\_\_\_

# Sterile Wrap Carts

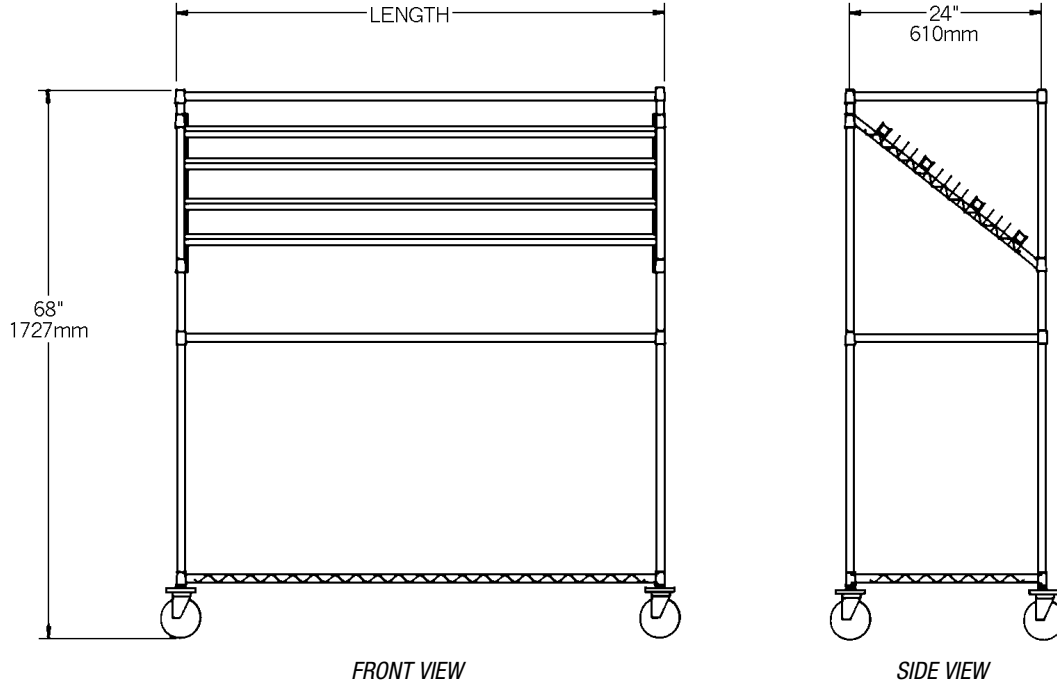

model #	width		length		height		weight	
	in.	mm	in.	mm	in.	mm	lbs.	kg
<b>SWC2448C</b>	24"	610	48"	1219	68"	1727	83	37.6
<b>SWC2460C</b>	24"	610	60"	1524	68"	1727	94	42.6

### Optional Sterile Wrap Cart Covers

uncoated w/zipper model #	uncoated w/velcro model #	coated w/zipper model #	coated w/velcro model #	shelf width in. mm	shelf length in. mm	post height in. mm	weight lbs. kg
<b>CZ-63-2448</b>	<b>CV-63-2448</b>	<b>CZC-63-2448</b>	<b>CVC-63-2448</b>	24" 610	48" 1219	63" 1600	4 1.8
<b>CZ-63-2460</b>	<b>CV-63-2460</b>	<b>CZC-63-2460</b>	<b>CVC-63-2460</b>	24" 610	60" 1524	63" 1600	5 2.3

### Additional Support Bars

model #	length in. mm	weight lbs. kg
<b>SB48</b>	48" 1219	2.7 1.2
<b>SB60</b>	60" 1524	3.4 1.5

**EAGLE GROUP**  
 100 Industrial Boulevard, Clayton, DE 19938-8903 USA  
 Phone: 302-653-3000 or 800-441-8440 • Fax: 302-653-2065  
 www.eaglegrp.com • www.eaglegrpnews.com • www.eaglehmc.com

Printed in U.S.A.  
 ©2023 by Eagle Group  
 Rev. 06/23

**Spec sheets available for viewing, printing or downloading from our online literature library at our websites**

Although every attempt has been made to ensure the accuracy of the information provided, we cannot be held responsible for typographical or printing errors. Information and specifications are subject to change without notice. Please confirm at time of order.