



Profit from the Eagle Advantage®

Specification Sheet

Short Form Specifications

Eagle AdjuSTable® Work Surface System with Wire Overshelf System, model _____. Heavy gauge brushed stainless steel top with choice of base combination: one wire undershelf and one C-frame or H-frame, or two C-frames or H-frames. Two 14"-wide (chrome, stainless steel) wire overshelves. Two 33" front posts, two 63" rear posts, and two 29" front posts for wire overshelves. Wire undershelves and overshelves feature patented QuadTruss® design (patent #5,390,803).



AdjuSTable® with Wire Overhead System—
shown with two C-frame bases

Options / Accessories

- Drawers
- Utility drawers**
- Lock
- Keyboard stations**
- Casters
- Additional undershelves

** See back page for these options.

EAGLE GROUP

100 Industrial Boulevard, Clayton, DE 19938-8903 USA
 Phone: 302-653-3000 • 800-441-8440 • Fax: 302-653-2065
www.eaglegrp.com
www.eaglegrpnews.com
www.eaglemhc.com

For custom configuration or fabrication needs, contact our **SpecFAB® Division**.
 Phone: 302-653-3000 • Fax: 302-653-2065 • e-mail: quotes@eaglegrp.com

Item No.: _____
 Project No.: _____
 S.I.S. No.: _____

AdjuSTable® Work Surface System with Wire Overhead System

MODELS:

- WO*2436*
- WO*3036*
- WO*3636*
- KBD-1/SS
- WO*2448*
- WO*3048*
- WO*3648*
- 501571
- WO*2460*
- WO*3060*
- WO*3660*
- 501572
- WO*2472*
- WO*3072*
- WO*3672*

* See charts for complete model numbers.

Design and Construction Features on All Units

- Stainless steel work surface available in solid or perforated, with brushed finish.
- All work surface tabletops feature hat channel underneath for added strength.
- Two 33" (838mm) front posts.
- Two 63" (1600mm) rear posts.
- Two 29" (737mm) front posts for wire overshelves.
- All posts are numbered in 1" (25mm) increments for flexible and level positioning of the base that you choose. Available in chrome or stainless steel finish.
- Two 14" (356mm)-wide chrome or stainless steel wire overshelves mount to rear posts and to 29" (737mm) posts.
- Base combination available with or without wire undershelf, with chrome or stainless steel H-frame(s) or C-frame(s).
- An almost unlimited number of custom configurations can be created by adding undershelves.
- 34½" (876mm) working height.

Certifications / Approvals





Profit from the Eagle Advantage®

Adjustable® Work Surface Systems with Wire Overhead System

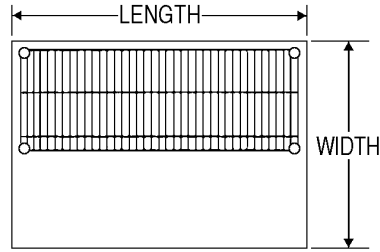

TOP VIEW

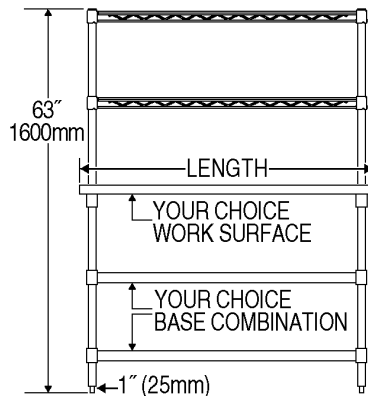

FRONT VIEW

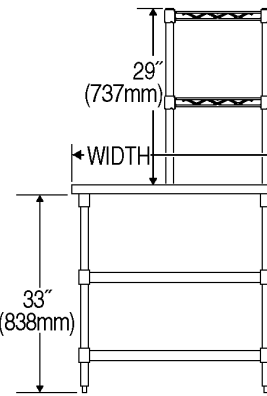

SIDE VIEW

“WOAC” Series Tables

Brushed 16/304 stainless steel solid top and chrome wire overshelves, with choice of:

- Two knocked down chrome C-frames
- Two knocked down chrome H-frames
- One chrome C-frame and one chrome wire undershelf
- One chrome H-frame and one chrome wire undershelf
- Two chrome wire undershelves

length		weight		WITH TWO C-FRAMES	WITH TWO H-FRAMES	WITH ONE C-FRAME AND ONE WIRE SHELF	WITH ONE H-FRAME AND ONE WIRE SHELF	WITH TWO WIRE SHELVES
in.	mm	lb.	kg	model #	model #	model #	model #	model #
24" x 36"	610 x 914	65	29.5	WOAC2436T-2C	WOAC2436T-2H	WOAC2436T-1C-1W	WOAC2436T-1H-1W	WOAC2436T-2W
24" x 48"	610 x 1219	81	36.7	WOAC2448T-2C	WOAC2448T-2H	WOAC2448T-1C-1W	WOAC2448T-1H-1W	WOAC2448T-2W
24" x 60"	610 x 1524	97	44.0	WOAC2460T-2C	WOAC2460T-2H	WOAC2460T-1C-1W	WOAC2460T-1H-1W	WOAC2460T-2W
24" x 72"	610 x 1829	113	51.3	WOAC2472T-2C	WOAC2472T-2H	WOAC2472T-1C-1W	WOAC2472T-1H-1W	WOAC2472T-2W
30" x 36"	762 x 914	75	34.0	WOAC3036T-2C	WOAC3036T-2H	WOAC3036T-1C-1W	WOAC3036T-1H-1W	WOAC3036T-2W
30" x 48"	762 x 1219	94	42.6	WOAC3048T-2C	WOAC3048T-2H	WOAC3048T-1C-1W	WOAC3048T-1H-1W	WOAC3048T-2W
30" x 60"	762 x 1524	113	51.3	WOAC3060T-2C	WOAC3060T-2H	WOAC3060T-1C-1W	WOAC3060T-1H-1W	WOAC3060T-2W
30" x 72"	762 x 1829	132	59.9	WOAC3072T-2C	WOAC3072T-2H	WOAC3072T-1C-1W	WOAC3072T-1H-1W	WOAC3072T-2W
36" x 36"	914 x 914	85	38.6	WOAC3636T-2C	WOAC3636T-2H	WOAC3636T-1C-1W	WOAC3636T-1H-1W	WOAC3636T-2W
36" x 48"	914 x 1219	108	49.0	WOAC3648T-2C	WOAC3648T-2H	WOAC3648T-1C-1W	WOAC3648T-1H-1W	WOAC3648T-2W
36" x 60"	914 x 1524	131	59.4	WOAC3660T-2C	WOAC3660T-2H	WOAC3660T-1C-1W	WOAC3660T-1H-1W	WOAC3660T-2W
36" x 72"	914 x 1829	154	69.9	WOAC3672T-2C	WOAC3672T-2H	WOAC3672T-1C-1W	WOAC3672T-1H-1W	WOAC3672T-2W



Profit from the Eagle Advantage®

AdjuSTable® Work Surface Systems with Wire Overhead System

“WOAS” Series Tables

Brushed 16/304 stainless steel solid top and stainless steel wire overshelves, with choice of:

- Two knocked down stainless steel C-frames
- Two knocked down stainless steel H-frames
- One stainless steel C-frame and one stainless steel wire undershelf
- One stainless steel H-frame and one chrome wire undershelf
- Two stainless steel wire undershelves

length		weight		WITH TWO C-FRAMES	WITH TWO H-FRAMES	WITH ONE C-FRAME AND ONE WIRE SHELF	WITH ONE H-FRAME AND ONE WIRE SHELF	WITH TWO WIRE SHELVES
in.	mm	lb.	kg	model #	model #	model #	model #	model #
24" x 36"	610 x 914	65	29.5	WOAS2436T-2C	WOAS2436T-2H	WOAS2436T-1C-1W	WOAS2436T-1H-1W	WOAS2436T-2W
24" x 48"	610 x 1219	81	36.7	WOAS2448T-2C	WOAS2448T-2H	WOAS2448T-1C-1W	WOAS2448T-1H-1W	WOAS2448T-2W
24" x 60"	610 x 1524	97	44.0	WOAS2460T-2C	WOAS2460T-2H	WOAS2460T-1C-1W	WOAS2460T-1H-1W	WOAS2460T-2W
24" x 72"	610 x 1829	113	51.3	WOAS2472T-2C	WOAS2472T-2H	WOAS2472T-1C-1W	WOAS2472T-1H-1W	WOAS2472T-2W
30" x 36"	762 x 914	75	34.0	WOAS3036T-2C	WOAS3036T-2H	WOAS3036T-1C-1W	WOAS3036T-1H-1W	WOAS3036T-2W
30" x 48"	762 x 1219	94	42.6	WOAS3048T-2C	WOAS3048T-2H	WOAS3048T-1C-1W	WOAS3048T-1H-1W	WOAS3048T-2W
30" x 60"	762 x 1524	113	51.3	WOAS3060T-2C	WOAS3060T-2H	WOAS3060T-1C-1W	WOAS3060T-1H-1W	WOAS3060T-2W
30" x 72"	762 x 1829	132	59.9	WOAS3072T-2C	WOAS3072T-2H	WOAS3072T-1C-1W	WOAS3072T-1H-1W	WOAS3072T-2W
36" x 36"	914 x 914	85	38.6	WOAS3636T-2C	WOAS3636T-2H	WOAS3636T-1C-1W	WOAS3636T-1H-1W	WOAS3636T-2W
36" x 48"	914 x 1219	108	49.0	WOAS3648T-2C	WOAS3648T-2H	WOAS3648T-1C-1W	WOAS3648T-1H-1W	WOAS3648T-2W
36" x 60"	914 x 1524	131	59.4	WOAS3660T-2C	WOAS3660T-2H	WOAS3660T-1C-1W	WOAS3660T-1H-1W	WOAS3660T-2W
36" x 72"	914 x 1829	154	69.9	WOAS3672T-2C	WOAS3672T-2H	WOAS3672T-1C-1W	WOAS3672T-1H-1W	WOAS3672T-2W

“WOAP” Series Tables

Brushed 14/304 stainless steel perforated* top (3/8"-diameter holes on 1" center) and stainless steel wire overshelves, with choice of:

* For perforated tops, laminar air flow is 23-25%, depending on size.

- Two knocked down stainless steel C-frames
- Two knocked down stainless steel H-frames
- One stainless steel C-frame and one stainless steel wire undershelf
- One stainless steel H-frame and one stainless steel wire undershelf
- Two stainless steel wire undershelves

length		weight		WITH TWO C-FRAMES	WITH TWO H-FRAMES	WITH ONE C-FRAME AND ONE WIRE SHELF	WITH ONE H-FRAME AND ONE WIRE SHELF	WITH TWO WIRE SHELVES
in.	mm	lb.	kg	model #	model #	model #	model #	model #
24" x 36"	610 x 914	65	29.5	WOAP2436T-2C	WOAP2436T-2H	WOAP2436T-1C-1W	WOAP2436T-1H-1W	WOAP2436T-2W
24" x 48"	610 x 1219	81	36.7	WOAP2448T-2C	WOAP2448T-2H	WOAP2448T-1C-1W	WOAP2448T-1H-1W	WOAP2448T-2W
24" x 60"	610 x 1524	97	44.0	WOAP2460T-2C	WOAP2460T-2H	WOAP2460T-1C-1W	WOAP2460T-1H-1W	WOAP2460T-2W
24" x 72"	610 x 1829	113	51.3	WOAP2472T-2C	WOAP2472T-2H	WOAP2472T-1C-1W	WOAP2472T-1H-1W	WOAP2472T-2W
30" x 36"	762 x 914	75	34.0	WOAP3036T-2C	WOAP3036T-2H	WOAP3036T-1C-1W	WOAP3036T-1H-1W	WOAP3036T-2W
30" x 48"	762 x 1219	94	42.6	WOAP3048T-2C	WOAP3048T-2H	WOAP3048T-1C-1W	WOAP3048T-1H-1W	WOAP3048T-2W
30" x 60"	762 x 1524	113	51.3	WOAP3060T-2C	WOAP3060T-2H	WOAP3060T-1C-1W	WOAP3060T-1H-1W	WOAP3060T-2W
30" x 72"	762 x 1829	132	59.9	WOAP3072T-2C	WOAP3072T-2H	WOAP3072T-1C-1W	WOAP3072T-1H-1W	WOAP3072T-2W
36" x 36"	914 x 914	85	38.6	WOAP3636T-2C	WOAP3636T-2H	WOAP3636T-1C-1W	WOAP3636T-1H-1W	WOAP3636T-2W
36" x 48"	914 x 1219	108	49.0	WOAP3648T-2C	WOAP3648T-2H	WOAP3648T-1C-1W	WOAP3648T-1H-1W	WOAP3648T-2W
36" x 60"	914 x 1524	131	59.4	WOAP3660T-2C	WOAP3660T-2H	WOAP3660T-1C-1W	WOAP3660T-1H-1W	WOAP3660T-2W
36" x 72"	914 x 1829	154	69.9	WOAP3672T-2C	WOAP3672T-2H	WOAP3672T-1C-1W	WOAP3672T-1H-1W	WOAP3672T-2W

Spec sheets available for viewing, printing or downloading from our online literature library at our websites

Eagle Foodservice Equipment, Eagle MHC, and SpecFAB® are divisions of Eagle Group. ©2023 by the Eagle Group



Item No.: _____
 Project No.: _____
 S.I.S. No.: _____

Adjustable® Work Surface Systems with Wire Overhead System

Options

Optional Table Mount Keyboard Station

20½" wide x 11½" deep (521 x 292mm).

weight		stainless steel
lbs.	kg	
6.0	2.7	KBD-1/SS

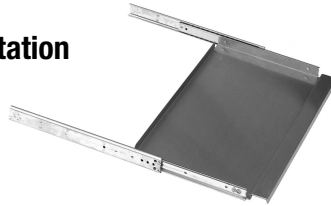

Optional Utility Drawers

Stainless steel construction. Guides and rollers included.

length			width			height			WITH PULL FLANGE AND PULL FRONT			ENCLOSED * ASSEMBLY		
in.	mm		in.	mm		in.	mm		weight		model #	weight		model #
lbs.	kg		lbs.	kg		lbs.	kg		lbs.	kg	model #	lbs.	kg	model #
20"	508		20"	508		5"	127		25	11.3	501571	35	15.9	501572

* Assembly comes complete with housing, drawer, drawer pan, and drawer front.



#501571



#501572

NEW Foot Rest

Available for use with adjustable® systems.

See Product Announcement **EG8224**



EAGLE GROUP

100 Industrial Boulevard, Clayton, DE 19938-8903 USA

Phone: 302-653-3000 or 800-441-8440 • Fax: 302-653-2065

www.eaglegrp.com • www.eaglegrpnews.com • www.eaglehmc.com

Printed in U.S.A.
©2023 by Eagle Group

Rev. 10/23

Spec sheets available for viewing, printing or downloading from our online literature library at our websites

Although every attempt has been made to ensure the accuracy of the information provided, we cannot be held responsible for typographical or printing errors. Information and specifications are subject to change without notice. Please confirm at time of order.