



Profit from the Eagle Advantage®

Specification Sheet

Short Form Specifications

Frame construction from wire shelf components in stainless steel or chrome plating. 1"-diameter posts grooved on 1" increments. Hanger bars featuring 2½" centered slots, hooks on 1½" centers staggered vertically, or 1"-diameter hanger tube are adaptations for storing gowns. Hangers not included.



rack with hanger slots



rack with hooks

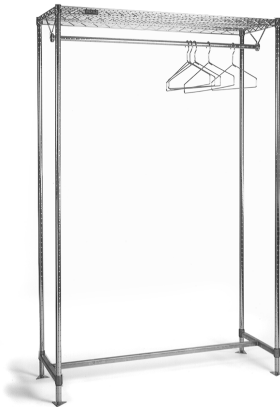

rack with hanger tube

(hangers shown above not included)

Options / Accessories

- Hangers
- Keeper bars (for Racks with Hanger Slots)
- Foot plates

EAGLE GROUP

100 Industrial Boulevard, Clayton, DE 19938-8903 USA
 Phone: 302-653-3000 • 800-441-8440 • Fax: 302-653-2065
www.eaglegrp.com
www.eaglegrpnews.com
www.eaglemhc.com

For custom configuration or fabrication needs, contact our **SpecFAB® Division**.
 Phone: 302-653-3000 • Fax: 302-653-2065 • e-mail: quotes@eaglegrp.com

Item No.: _____
 Project No.: _____
 S.I.S. No.: _____

Freestanding Gowning Racks with Wire Shelving Components

MODELS:

- EP24*
- EP14*
- S24*
- C24*
- C14*

* See charts on back for complete model numbers.

Racks with Hanger Slots

- Hanger bar constructed of heavy gauge type 304 stainless steel with hanger slots spaced on 2½" (64mm) centers.
- 1" (25mm) square 3-sided frame along the bottom.
- Finishes available are chrome and stainless steel finish.

Racks with Hooks

- Top wire shelf features 2 gauge hooks welded to underside of top wire shelf.
- Standard wire undershelf.
- Finishes available are chrome and stainless steel finish.

Racks with Hanger Tube

- 1" (25mm)-diameter full-length hanger tube, grooved at 1" (25mm) increments, is suspended on underside of wire shelf via two 2-gauge hooks, one on each end.
- 1" (25mm) square H-frame along the bottom.
- Finishes available are chrome and stainless steel finish.
- Weight capacity: 50 lbs. (22.7 kg).

Wire Shelving Components

- All units feature wire shelf with patented QuadTruss® construction (patent #5,390,803):
 - Top mat assembly constructed of 10 gauge mat wires welded to full-length 6 gauge inside support wires and serpentine trusses.
 - At front and rear of shelf, mat wires are welded to a four-wire truss assembly constructed of a 2 gauge bottom wire, a 6 gauge serpentine truss wire which creates a bridge-like reinforcement, and two 6 gauge top wires—one directly below mat wires and one directly above, providing a pincer hold on mat wires.
- Posts are 1" (25mm) diameter, grooved on 1" (25mm) increments, and provided with leveling feet. Optional foot plates available to affix gowning rack to the floor.

(Wall Mounted Gowning Racks available. See catalog sheet EG04.08)



Profit from the Eagle Advantage®

Item No.: _____
 Project No.: _____
 S.I.S. No.: _____

Freestanding Gowning Racks with Wire Shelving Components

Racks with Hanger Slots

Hanger slots on standard 2½" (64mm) centers. Hangers sold separately.

chrome model #	stainless steel model #	width in. mm	length in. mm	weight lbs. kg	number of hanger slots
C2448-GR	S2448-GR	24" 610	48" 1219	53 24.0	17
C2460-GR	S2460-GR	24" 610	60" 1524	66 29.9	22
C2472-GR	S2472-GR	24" 610	72" 1829	71 32.2	27

Optional Keeper Bars

Keeps hangers in place.

chrome model #	stainless steel model #
KB48-C	KB48-S
KB60-C	KB60-S
KB72-C	KB72-S

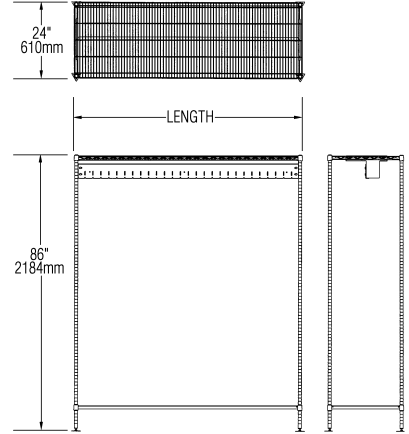

Number of Hanger Slots on Optional Spacing

unit length in. mm	on 1½" (38mm) centers	on 2" (51mm) centers	on 3" (76mm) centers
48" 1219	29	21	14
60" 1524	36	27	18
72" 1829	44	33	22

Racks with Hooks

Hooks, on all four shelf sides, are spaced on 1½" (38mm) centers and are staggered 1" (25mm) vertically hook-to-hook for ease of access.

chrome model #	stainless steel model #	width in. mm	length in. mm	weight lbs. kg	number of hooks
C1448-GRH	S1448-GRH	14" 356	48" 1219	56 25.4	72
C1460-GRH	S1460-GRH	14" 356	60" 1524	68 30.8	88
C1472-GRH	S1472-GRH	14" 356	72" 1829	80 36.3	104

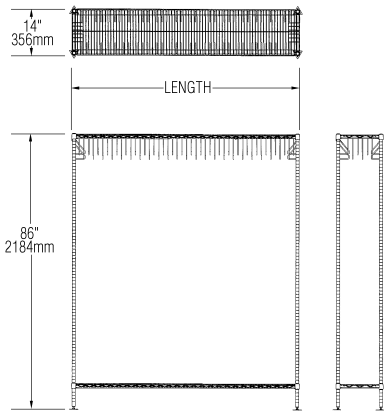

Racks with Hanger Tube

Features 1" (25mm) diameter tubular bar which easily mounts to underside of wire shelf. Facilitates laminar flow. Hangers sold separately.

chrome model #	stainless steel model #	width in. mm	length in. mm	weight lbs. kg
C2448-GRT	S2448-GRT	24" 610	48" 1219	56 25.4
C2460-GRT	S2460-GRT	24" 610	60" 1524	68 30.8
C2472-GRT	S2472-GRT	24" 610	72" 1829	82 37.2

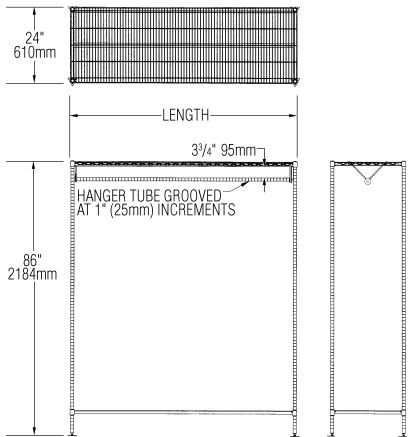

EAGLE GROUP

100 Industrial Boulevard, Clayton, DE 19938-8903 USA

Phone: 302-653-3000 or 800-441-8440 • Fax: 302-653-2065

www.eaglegrp.com • www.eaglegrpnews.com • www.eaglehmc.com

Printed in U.S.A.

©2023 by Eagle Group

Rev. 10/23

Spec sheets available for viewing, printing or downloading from our online literature library at our websites

Although every attempt has been made to ensure the accuracy of the information provided, we cannot be held responsible for typographical or printing errors. Information and specifications are subject to change without notice. Please confirm at time of order.