



Profit from the Eagle Advantage®

Specification Sheet

Short Form Specifications

Eagle QuadPLUS®, model _____. Consists of (1) Standard truss frame with louvered QuadPLUS® blue shelf mats; (3) Quad-Adjust® truss frames with louvered QuadPLUS® blue shelf mats; (1) Standard truss frame with solid QuadPLUS® blue shelf mats; and (4) 74" (1880mm) posts. Mobile units feature 5" (127mm) resilient swivel stem casters—two with brake.

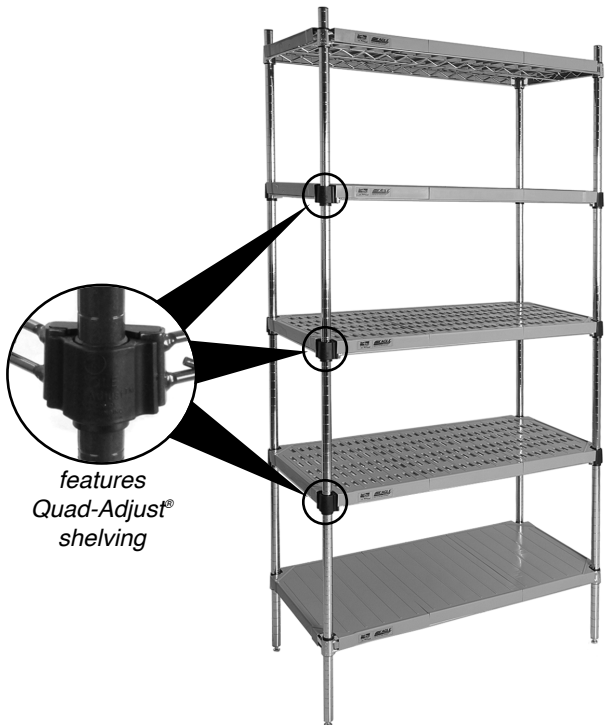

QuadPLUS® stationary starter unit

Options / Accessories

- Dividers
- Wire Baskets

EAGLE GROUP

100 Industrial Boulevard, Clayton, DE 19938-8903 USA
 Phone: 302-653-3000 • 800-441-8440 • Fax: 302-653-2065
www.eaglegrp.com
www.eaglegrpnews.com
www.eaglemhc.com

For custom configuration or fabrication needs, contact our **SpecFAB® Division**.
 Phone: 302-653-3000 • Fax: 302-653-2065 • e-mail: quotes@eaglegrp.com

Item No.: _____
 Project No.: _____
 S.I.S. No.: _____

QuadPLUS® 5-Tier Starter Units

MODELS:

- | | |
|---|---|
| <input type="checkbox"/> QPMU18*C-B5-74 | <input type="checkbox"/> QPSU18*C-B5-74 |
| <input type="checkbox"/> QPMU21*C-B5-74 | <input type="checkbox"/> QPSU24*C-B5-74 |
| <input type="checkbox"/> QPMU24*C-B5-74 | <input type="checkbox"/> QPSU21*C-B5-74 |
| <input type="checkbox"/> QPMU18*V-B5-74 | <input type="checkbox"/> QPSU18*V-B5-74 |
| <input type="checkbox"/> QPMU21*V-B5-74 | <input type="checkbox"/> QPSU24*V-B5-74 |
| <input type="checkbox"/> QPMU24*V-B5-74 | <input type="checkbox"/> QPSU21*V-B5-74 |

* See charts below for complete model numbers.

Features

- (1) Standard truss frame with louvered QuadPLUS® blue shelf mats.
- (3) Quad-Adjust® truss frames with louvered QuadPLUS® blue shelf mats.
- (1) Standard truss frame with solid QuadPLUS® blue shelf mats.
- (4) 74" (1880mm) posts.
- Stationary and mobile units available. Mobile units feature 5" (127mm) resilient swivel stem casters—two with brake.
- Mats snap securely on top of truss frame or on top of an existing standard wire shelf.
- Truss frames and shelves adjustable at 1" increments to accommodate many applications.
- Injection-molded polypropylene mats feature MICROGARD® antimicrobial protection against bacteria, mold and mildew.
- Easy cleaning, dishwasher-safe.
- Truss frames coated with chrome or Valu-Master® gray epoxy finish (other finishes available, consult factory).
- Set of four split sleeves (included with each truss frame) snap onto Eagle's 1"-diameter posts.
- Temperature rating: Up to 200°F* for intermittent exposure to cleaning, such as in a dishwasher.

* Temperature rating of -20°F to 120°F under continuous use.

Certifications / Approvals



EG01.36M Rev. 10/23

Spec sheets available for viewing, printing or downloading from our online literature library at our websites

Eagle Foodservice Equipment, Eagle MHC, and SpecFAB® are divisions of Eagle Group. ©2023 by the Eagle Group

Item No.: _____
 Project No.: _____
 S.I.S. No.: _____

QuadPLUS® 5-Tier Starter Units

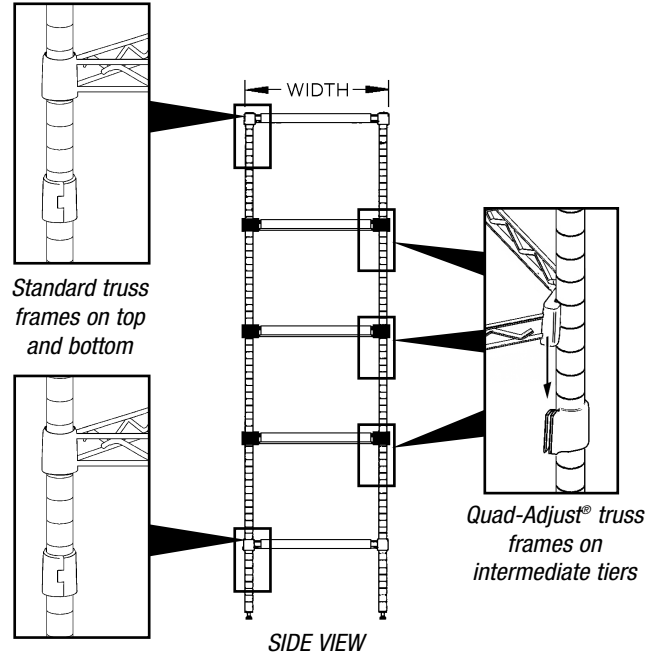
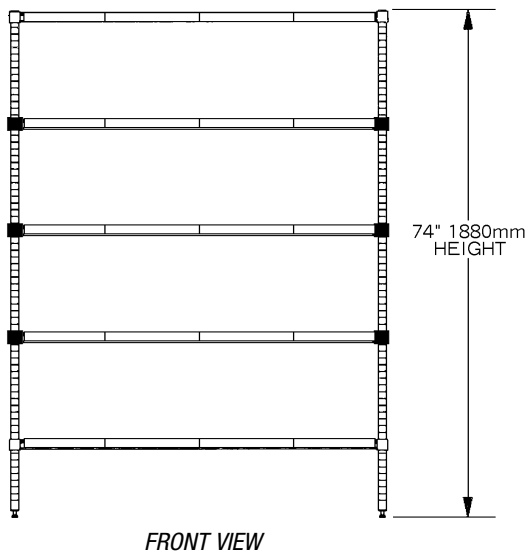
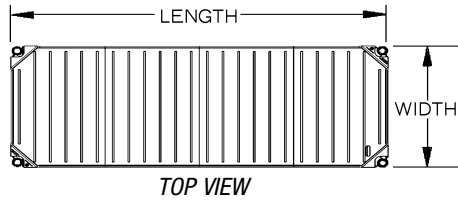

(stationary shelf unit shown)

width x length		...w/VALU-MASTER® gray epoxy		...with Chrome finish	
in.	mm	STATIONARY model #	MOBILE model #	STATIONARY model #	MOBILE model #
18" x 36"	457 x 914	QPSU1836V-B5-74	QPMU1836V-B5-74	QPSU1836C-B5-74	QPMU1836C-B5-74
18" x 48"	457 x 1219	QPSU1848V-B5-74	QPMU1848V-B5-74	QPSU1848C-B5-74	QPMU1848C-B5-74
18" x 60"	457 x 1524	QPSU1860V-B5-74	QPMU1860V-B5-74	QPSU1860C-B5-74	QPMU1860C-B5-74
21" x 36"	533 x 914	QPSU2136V-B5-74	QPMU2136V-B5-74	QPSU2136C-B5-74	QPMU2136C-B5-74
21" x 48"	533 x 1219	QPSU2148V-B5-74	QPMU2148V-B5-74	QPSU2148C-B5-74	QPMU2148C-B5-74
21" x 60"	533 x 1524	QPSU2160V-B5-74	QPMU2160V-B5-74	QPSU2160C-B5-74	QPMU2160C-B5-74
24" x 36"	610 x 914	QPSU2436V-B5-74	QPMU2436V-B5-74	QPSU2436C-B5-74	QPMU2436C-B5-74
24" x 48"	610 x 1219	QPSU2448V-B5-74	QPMU2448V-B5-74	QPSU2448C-B5-74	QPMU2448C-B5-74
24" x 60"	610 x 1524	QPSU2460V-B5-74	QPMU2460V-B5-74	QPSU2460C-B5-74	QPMU2460C-B5-74

EAGLE GROUP

100 Industrial Boulevard, Clayton, DE 19938-8903 USA

Phone: 302-653-3000 or 800-441-8440 • Fax: 302-653-2065

www.eaglegrp.com • www.eaglegrpnews.com • www.eaglehmc.com

Printed in U.S.A.

©2023 by Eagle Group

Rev. 10/23

Spec sheets available for viewing, printing or downloading from our online literature library at our websites

Although every attempt has been made to ensure the accuracy of the information provided, we cannot be held responsible for typographical or printing errors. Information and specifications are subject to change without notice. Please confirm at time of order.