



Profit from the Eagle Advantage®

Specification Sheet

Short Form Specifications

Eagle Black Polymer Utility Cart, model EU3-2030-P. Shelves and handles are heavy duty black polymer—three shelves, one push handle per end. Uprights are brushed aluminum. 4"-dia. non-marking swivel casters. Weight capacity up to 200 lbs.

Item No.:	_____
Project No.:	_____
S.I.S. No.:	_____

Black Polymer Utility Cart

MODELS:

EU3-2030-P



black polymer utility cart

- Heavy duty black polymer shelves with lip on three sides.
- Heavy duty black polymer push handle on each end of cart.
- High style appearance with brushed aluminum uprights.
- 4" (102mm)-diameter non-marking swivel casters.
- 37 $\frac{3}{4}$ " (959mm) overall height, including casters.
- 200 lb. (90.7 kg) weight capacity per cart.

EAGLE GROUP

100 Industrial Boulevard, Clayton, DE 19938-8903 USA
 Phone: 302-653-3000 • 800-441-8440 • Fax: 302-653-2065
www.eaglegrp.com
www.eaglegrpnews.com
www.eaglemhc.com

For custom configuration or fabrication needs, contact our **SpecFAB® Division**.
 Phone: 302-653-3000 • Fax: 302-653-2065 • e-mail: quotes@eaglegrp.com





Item No.: _____
 Project No.: _____
 S.I.S. No.: _____

Black Polymer Utility Cart

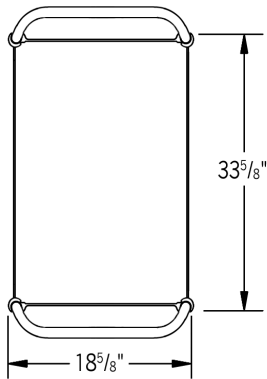

TOP VIEW

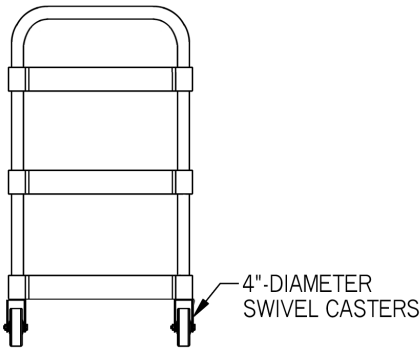

FRONT VIEW

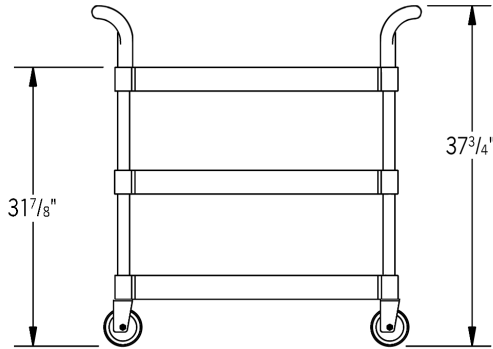

SIDE VIEW

model #	width x length		weight capacity		weight	
	in.	mm	lbs.	kg	lbs.	kg
EU3-2030-P	18 5/8"	473	200	90.7	30	13.6

EAGLE GROUP
 100 Industrial Boulevard, Clayton, DE 19938-8903 USA
 Phone: 302-653-3000 or 800-441-8440 • Fax: 302-653-2065
 www.eaglegrp.com • www.eaglegrpnews.com • www.eaglemhc.com

Printed in U.S.A.
 ©2023 by Eagle Group
 Rev. 10/23

Spec sheets available for viewing, printing or downloading from our online literature library at our websites

Although every attempt has been made to ensure the accuracy of the information provided, we cannot be held responsible for typographical or printing errors. Information and specifications are subject to change without notice. Please confirm at time of order.