



Profit from the Eagle Advantage®

Specification Sheet

Short Form Specifications

Eagle Double-Sided Bin Holder Rail Cart, model _____, Four bin holder rails with 63" posts, and resilient casters. Unit shipped knocked down.



shown assembled as a cart

PATENTED!
(patent #8,141,724 B2)

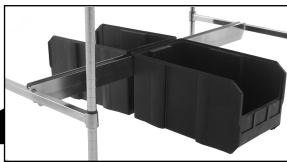

bin holder rail with two bins

(bins sold separately - see manufacturer's guide for recommended weight capacity)



Bin holder rails can also be used on Eagle's Floor-Trak® units*

* For additional information on Floor-Trak® Systems, refer to spec sheets EG01.39A and EG01.39B, or visit us online.

EAGLE GROUP

100 Industrial Boulevard, Clayton, DE 19938-8903 USA

Phone: 302-653-3000 • 800-441-8440 • Fax: 302-653-2065

www.eaglegrp.com

www.eaglegrpnews.com

www.eaglemhc.com

For custom configuration or fabrication needs, contact our SpecFAB® Division.

Phone: 302-653-3000 • Fax: 302-653-2065 • e-mail: quotes@eaglegrp.com

Item No.: _____

Project No.: _____

S.I.S. No.: _____

Double-Sided Bin Holder Rails and Carts

MODELS:

- DBH2436S DBH3036S DBHC2436C-4 DBHC3036C-4
- DBH2442S DBH3042S DBHC2442C-4 DBHC3042C-4
- DBH2448S DBH3048S DBHC2448C-4 DBHC3048C-4
- DBH2454S DBH3054S DBHC2454C-4 DBHC3054C-4
- DBH2460S DBH3060S DBHC2460C-4 DBHC3060C-4

* See chart on back page for complete model numbers.

Bin Holder Rails

- Sold as an accessory, or can be purchased with posts as a cart.
- All stainless steel construction.
- Bins can be attached to both sides of rail - no tools required.
- Available in 24" (305mm) or 30" (762mm) widths.
- 36" (914mm) through 60" (1524mm) rail lengths.
- May be mixed with standard wire shelves.

Bin Holder Rail Carts

- Four (4) bin holder rails.
- Four (4) 63" (1600mm) posts.
- Four (4) 5" (127mm)-diameter resilient tread casters.
- Posts are numbered in increments of 1" (25mm) to ensure fast and level assembly of bin holder rails.
- Posts are chrome-plated and bin rails are stainless steel.
- 68" (1727mm) overall cart height.

Item No.: _____
 Project No.: _____
 S.I.S. No.: _____

Double-Sided Bin Holder Rails and Carts

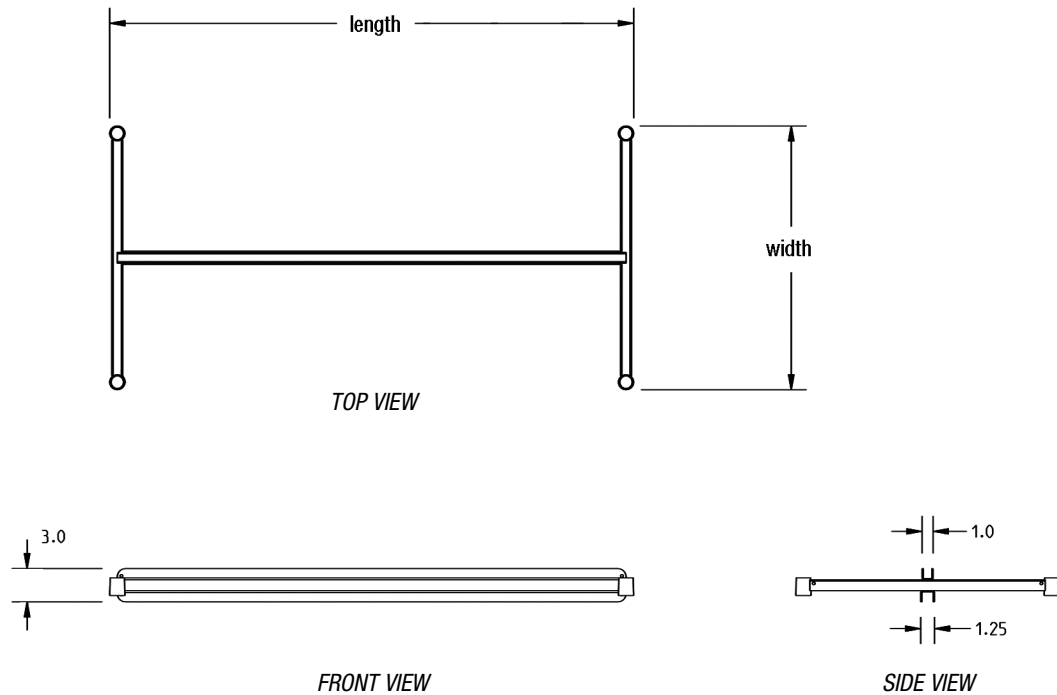

width x length		Bin Holder Rails			Bin Holder Rail Carts		
in.	mm	weight		stainless steel	weight		chrome posts with
		lbs.	kg	model #	lbs.	kg	stainless bin rails
							model #
24" x 36"	610 x 914	11.0	5.0	DBH2436S	64	29.0	DBHC2436C-4
24" x 42"	610 x 1067	12.5	5.7	DBH2442S	70	31.8	DBHC2442C-4
24" x 48"	610 x 1219	14.0	6.4	DBH2448S	76	34.5	DBHC2448C-4
24" x 54"	610 x 1372	15.5	7.0	DBH2454S	82	37.2	DBHC2454C-4
24" x 60"	610 x 1524	17.0	7.7	DBH2460S	88	39.9	DBHC2460C-4
30" x 36"	762 x 914	12.5	5.7	DBH3036S	70	31.8	DBHC3036C-4
30" x 42"	762 x 1067	14.0	6.4	DBH3042S	76	34.5	DBHC3042C-4
30" x 48"	762 x 1219	15.5	7.0	DBH3048S	82	37.2	DBHC3048C-4
30" x 54"	762 x 1372	17.0	7.7	DBH3054S	88	39.9	DBHC3054C-4
30" x 60"	762 x 1524	18.5	8.4	DBH3060S	94	42.6	DBHC3060C-4

EAGLE GROUP

100 Industrial Boulevard, Clayton, DE 19938-8903 USA

Phone: 302-653-3000 or 800-441-8440 • Fax: 302-653-2065

www.eaglegrp.com • www.eaglegrpnews.com • www.eaglehmc.com

Printed in U.S.A.
 ©2023 by Eagle Group
 Rev. 02/23

Spec sheets available for viewing, printing or downloading from our online literature library at our websites

Although every attempt has been made to ensure the accuracy of the information provided, we cannot be held responsible for typographical or printing errors. Information and specifications are subject to change without notice. Please confirm at time of order.