



Profit from the Eagle Advantage®

Specification Sheet

Short Form Specifications

Eagle Q-LEVER® Base Cabinet, model _____.
Top is 16/3 stainless steel, sides and back are heavy gauge stainless steel. (Open Front, Stainless Steel Sliding Door, or Stainless Steel Hinged Door) models with front and sides turned down 90°, and 4½" upturn on rear.

Item No.:	_____
Project No.:	_____
S.I.S. No.:	_____

Q-LEVER® Base Cabinets

MODELS:

- | | | |
|-------------------------------------|-------------------------------------|--------------------------------------|
| <input type="checkbox"/> QOB3036SEB | <input type="checkbox"/> QCB3036SEB | <input type="checkbox"/> QCBH3036SEB |
| <input type="checkbox"/> QOB3042SEB | <input type="checkbox"/> QCB3042SEB | <input type="checkbox"/> QCBH3042SEB |
| <input type="checkbox"/> QOB3048SEB | <input type="checkbox"/> QCB3048SEB | <input type="checkbox"/> QCBH3048SEB |



Design and Construction Features

- All stainless steel construction.
- Available with open front, sliding doors, or hinged doors.
- Doors are 20 gauge type 430 stainless steel.
- Top is 16 gauge type 304 stainless steel reinforced with a full length "hat" channel support.
- Body is heavy gauge type 430 stainless steel.
- 90° downturn on front and sides of top.
- 4½" (114mm) backsplash on rear.
- Optional fixed center shelf available. To order, add suffix "-CS" to model number. Example: QOB3036SEB-CS

Options / Accessories

- Additional center shelves
- Door lock (suffix -L) for cabinets with hinged or sliding doors

EAGLE GROUP

100 Industrial Boulevard, Clayton, DE 19938-8903 USA
 Phone: 302-653-3000 • 800-441-8440 • Fax: 302-653-2065
www.eaglegrp.com
www.eaglegrpnews.com
www.eaglemhc.com

For custom configuration or fabrication needs, contact our SpecFAB® Division.
 Phone: 302-653-3000 • Fax: 302-653-2065 • e-mail: quotes@eaglegrp.com



EG01.65 Rev. 01/23

Spec sheets available for viewing, printing or downloading from our online literature library at our websites

Eagle Foodservice Equipment, Eagle MHC, and SpecFAB® are divisions of Eagle Group. ©2023 by the Eagle Group



Item No.: _____
 Project No.: _____
 S.I.S. No.: _____

Q-LEVER® Base Cabinets

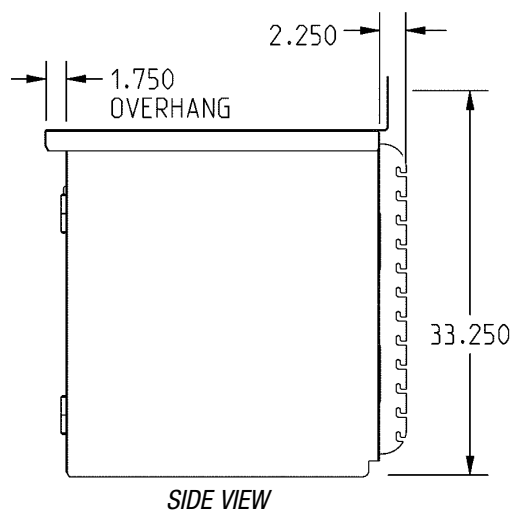
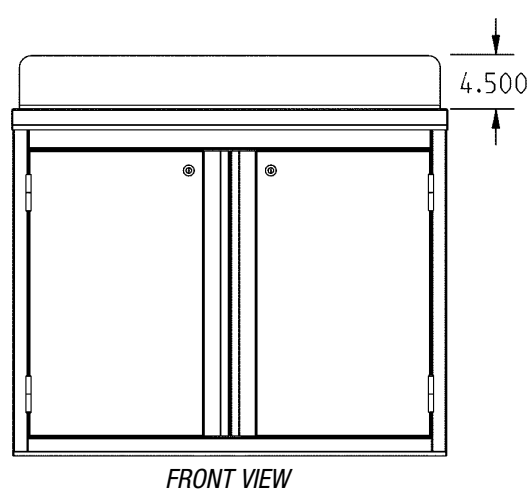
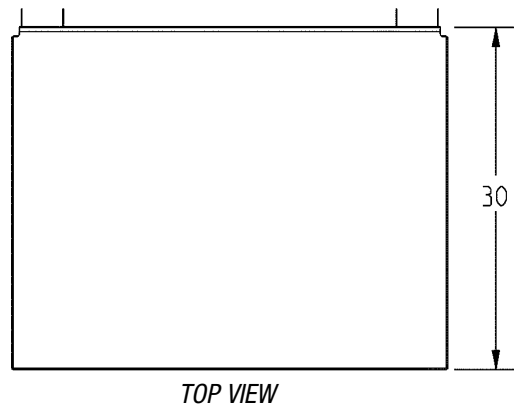

(cabinet with hinged doors shown)

...WITH OPEN FRONT	...WITH HINGED * DOORS	...WITH SLIDING * DOORS	weight		width		length	
model #	model #	model #	lbs.	kg	in.	mm	in.	mm
QOB3036SEB	QCBH3036SEB	QCB3036SEB	137	62.1	30"	762	36"	914
QOB3042SEB	QCBH3042SEB	QCB3042SEB	152	68.9	30"	762	42"	1067
QOB3048SEB	QCBH3048SEB	QCB3048SEB	167	75.8	30"	762	48"	1219

Optional door lock available for cabinets with doors. To order, add suffix -L (example: QCB3036SEB-L)

EAGLE GROUP
 100 Industrial Boulevard, Clayton, DE 19938-8903 USA
 Phone: 302-653-3000 or 800-441-8440 • Fax: 302-653-2065
 www.eaglegrp.com • www.eaglegrpnews.com • www.eaglehmc.com

Printed in U.S.A.
 ©2023 by Eagle Group
EG01.65 Rev. 01/23

Spec sheets available for viewing, printing or downloading from our online literature library at our websites

Although every attempt has been made to ensure the accuracy of the information provided, we cannot be held responsible for typographical or printing errors. Information and specifications are subject to change without notice. Please confirm at time of order.