



Profit from the Eagle Advantage®

Specification Sheet

Short Form Specifications

Eagle Hand Sink, model HSA-10-F-DS. Constructed of type 304 stainless steel, all-welded with deep-drawn positive drain sink bowl, inverted "V" edge to prevent spillage, drain, deck mount soap dispenser, and splash mounted gooseneck faucet.

Eagle Narrow Hand Sink, model HSA-10-F-DS. Constructed of type 304 stainless steel all-welded with 12" side-to-side deep-drawn positive drain sink bowl, inverted "V" edge to prevent spillage, drain, deck mounted soap dispenser, and splash mounted gooseneck faucet.



#HSA-10-F-DS



#HSA-10-F-DS

Options / Accessories

- Faucet with wrist handles
- Anti-scald valve
- Towel dispenser*
- P-trap
- End splashes
- Drinking bubbler

* Optional Towel Dispenser fits #HSA-10-F-DS only.

EAGLE GROUP

100 Industrial Boulevard, Clayton, DE 19938-8903 USA
 Phone: 302-653-3000 • 800-441-8440 • Fax: 302-653-2065
www.eaglegrp.com
www.eaglegrpnews.com
www.eaglemhc.com

For custom configuration or fabrication needs, contact our SpecFAB® Division.
Phone: 302-653-3000 • Fax: 302-653-2065 • e-mail: quotes@eaglegrp.com

Item No.: _____
 Project No.: _____
 S.I.S. No.: _____

Hand Sinks with Deck-Mounted Soap Dispensers

MODELS:

- HSA-10-F-DS
- HSA-10-F-DS

Design & Construction Features of Both Hand Sinks

- Standard deck-mounted pump-action liquid soap dispenser holds 16 oz., and features plastic globe and 4" (102mm) spout.
- Heavy gauge type 304 stainless steel all-welded construction.
- Splash-mounted gooseneck faucet on 4" (102mm) centers.
- Inverted "V" edge rim retards spillage.
- Unique deep-drawn positive-drain bowl assures complete drainage to meet the most stringent health code requirements.
- Includes 1½" (38mm) NPS stainless steel basket drain and mini crumb cup strainer.
- ½" (13mm) NPS water inlet.
- Furnished with stainless steel Z-clips to secure to wall.
- Includes splash mount gooseneck faucet, basket drain with mini crumb cup strainer, and soap dispenser.
- #HSA-10-F-DS is only 12" (305mm) side-to-side for maximum space efficiency.



Spec sheets available for viewing, printing or downloading from our online literature library at our websites



Item No.: _____
 Project No.: _____
 S.I.S. No.: _____

Hand Sinks with Deck-Mounted Soap Dispensers

Model #HSA-10-F-DS

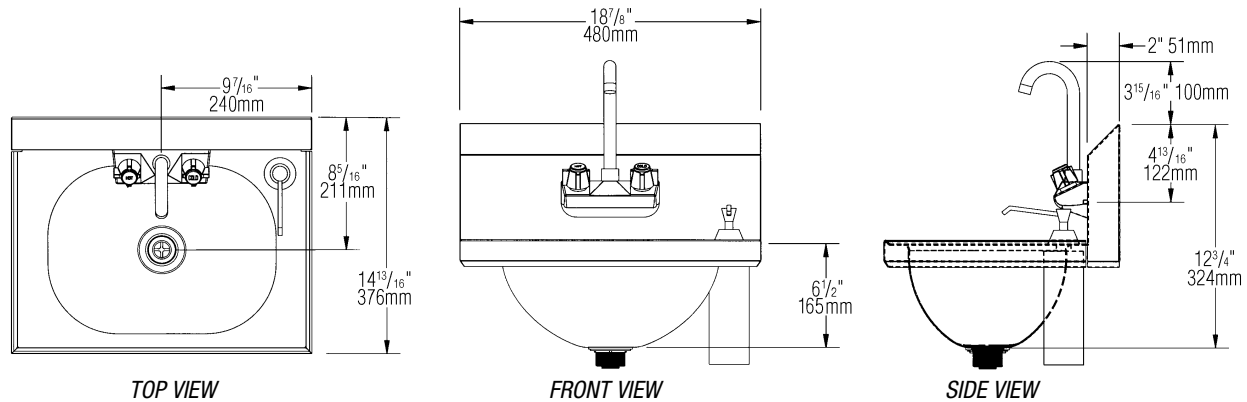

model #	bowl size		overall size		weight	
	width in.	length x depth mm	width in.	length x height mm	lbs.	kg
HSA-10-F-DS	9 ³ / ₄ "	13 ¹ / ₂ " x 6 ¹ / ₂ "	14 ¹³ / ₁₆ "	18 ⁷ / ₈ " x 12 ³ / ₄ "	12	5.2

Model #HSAN-10-F-DS

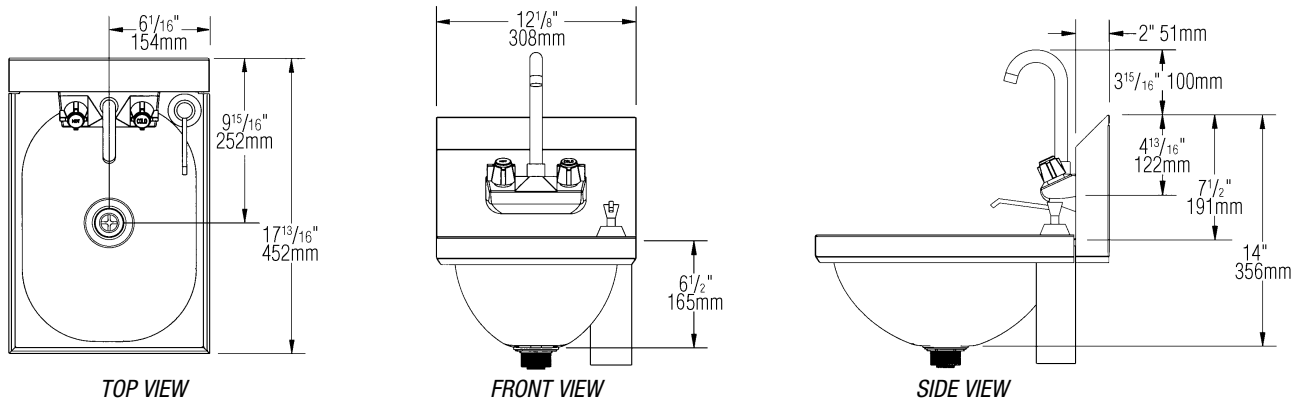

model #	bowl size		overall size		weight	
	width in.	length x depth mm	width in.	length x height mm	lbs.	kg
HSAN-10-F-DS	13 ¹ / ₂ "	9 ³ / ₄ " x 6 ¹ / ₂ "	17 ¹³ / ₁₆ "	12 ¹ / ₈ " x 14 ¹ / ₄ "	14	6.4

EAGLE GROUP

100 Industrial Boulevard, Clayton, DE 19938-8903 USA

Phone: 302-653-3000 or 800-441-8440 • Fax: 302-653-2065

www.eaglegrp.com • www.eaglegrpnews.com • www.eaglehmc.com

Printed in U.S.A.
 ©2023 by Eagle Group

Rev. 01/23

Spec sheets available for viewing, printing or downloading from our online literature library at our websites

Although every attempt has been made to ensure the accuracy of the information provided, we cannot be held responsible for typographical or printing errors. Information and specifications are subject to change without notice. Please confirm at time of order.