



Profit from the Eagle Advantage®

Specification Sheet

Short Form Specifications

Eagle One-Compartment Utility Sinks, model _____ . Constructed of type 304 or 430 stainless steel with square corners, Euro-Style edging on front, and 8" backsplash. All partitions have 5/8" rolled top edge. Faucet holes punched on 8" centers. All outside corners to be bullnosed for clean, safe edges. 1 1/2" O.D. galvanized tubular legs with adjustable bullet feet.



one-compartment utility sink

Options / Accessories

- Faucets
- Detachable drainboard *
- Lever waste
- Lever waste with overflow
- Stainless steel legs
- Stainless steel feet

* See Spec Sheet #EG20.13E for optional detachable drainboards.

Design and Construction Features:

- For numerous applications when NSF approval is not required (For NSF-approved utility sinks, add prefix "N-" to model number. Example: N-2424-1-16/3)
- Entire assembly is fuse welded and planished, providing a one-piece seamless sink unit.
- 34 1/2" to 35 1/2" (876 to 902mm) working height.

EAGLE GROUP

100 Industrial Boulevard, Clayton, DE 19938-8903 USA
 Phone: 302-653-3000 • 800-441-8440 • Fax: 302-653-2065
www.eaglegrp.com
www.eaglegrpnews.com
www.eaglemhc.com

For custom configuration or fabrication needs, contact our **SpecFAB® Division**.
 Phone: 302-653-3000 • Fax: 302-653-2065 • e-mail: quotes@eaglegrp.com

Item No.: _____
 Project No.: _____
 S.I.S. No.: _____

One-Compartment Utility Sinks with Square Corner Construction

MODELS:

- 1818-1-16/4
- 1818-1-16/3
- 1824-1-16/4
- 1824-1-16/3
- 2118-1-16/4
- 2118-1-16/3
- 2124-1-16/4
- 2124-1-16/3
- 2136-1-16/4
- 2136-1-16/3
- 2424-1-16/4
- 2424-1-16/3
- 2424-1-16/3
- 2436-1-16/4
- 2436-1-16/3
- 2124-1-18-16/4
- 2124-1-18-16/3
- 2424-1-24-16/4
- 2424-1-24-16/3

Top:

- All partitions have euro-style front edge.
- Available with detachable* or welded drainboards.
- 8" (203mm) splash features 2" (51mm) return to wall on 45° angle, with 1" (25mm) upturn.
- 1 1/8" (29mm) faucet holes punched on 8" (203mm) centers.

Legs:

- 1 1/2" (41mm)-diameter heavy-gauge galvanized tubing.
- High-impact corrosion-resistant 1" (25mm) adjustable bullet feet.
- Leg locations fall directly under sink bowl, providing increased stability and maximum weight support.

Sink Bowl:

- 16 gauge type 304 or 430 stainless steel.
- 13 3/8" (340mm)-deep compartment.
- 12-gauge leg gussets welded to a die-cut heavy-gauge reinforcing plate underneath sink bowl.
- Drain hole is 3 1/2" (89mm)-diameter, recessed, and complete with 1 1/2" (38mm) IPS basket-type waste drain, which is shipped loose.



EG20.13A Rev. 01/23

Spec sheets available for viewing, printing or downloading from our online literature library at our websites

Eagle Foodservice Equipment, Eagle MHC, and SpecFAB® are divisions of Eagle Group. ©2023 by the Eagle Group



Profit from the Eagle Advantage®

Item No.: _____
 Project No.: _____
 S.I.S. No.: _____

One-Compartment Utility Sinks with Square Corner Construction

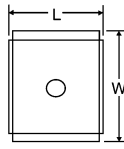
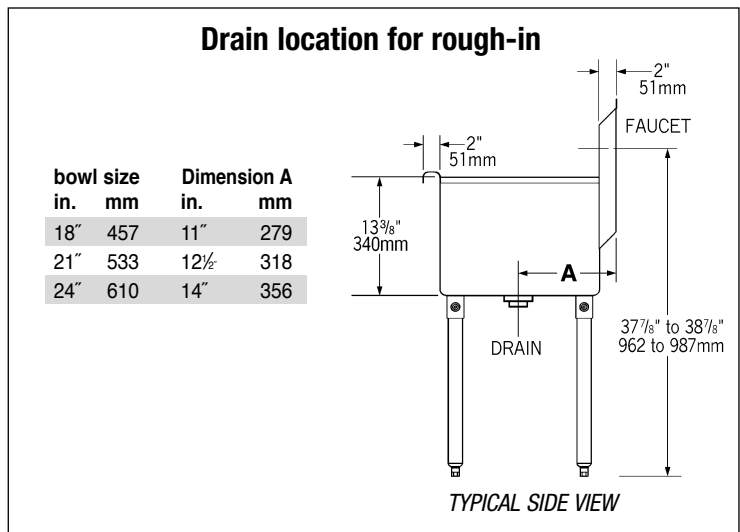

Sinks with No Drainboards

16 gauge type 430 stainless steel model #	16 gauge type 304 stainless steel model #	BOWL DIMENSIONS				DRAINBOARD		OVERALL DIMENSIONS				weight	
		width in.	width mm	length in.	length mm	quantity	length in. mm	width in.	width mm	length in.	length mm	lbs.	kg
1818-1-16/4	1818-1-16/3	18"	457	18"	457	0	n/a	22"	559	19⅞"	492	53	24.0
1824-1-16/4	1824-1-16/3	18"	457	24"	610	0	n/a	22"	559	25⅝"	645	56	25.4
2118-1-16/4	2118-1-16/3	21"	533	18"	457	0	n/a	25"	635	19⅞"	492	56	25.4
2124-1-16/4	2124-1-16/3	21"	533	24"	610	0	n/a	25"	635	25⅝"	645	61	27.7
2136-1-16/4	2136-1-16/3	21"	533	36"	914	0	n/a	25"	635	37⅞"	949	66	29.9
2424-1-16/4	2424-1-16/3	24"	610	24"	610	0	n/a	28"	711	25⅝"	645	60	27.2
2436-1-16/4	2436-1-16/3	24"	610	36"	914	0	n/a	28"	711	37⅞"	949	68	30.8

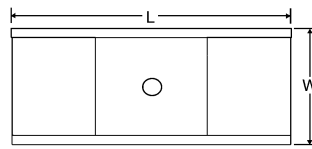

Sinks with Double Drainboards

16 gauge type 430 stainless steel model #	16 gauge type 304 stainless steel model #	BOWL DIMENSIONS				DRAINBOARD		OVERALL DIMENSIONS				weight	
		width in.	width mm	length in.	length mm	quantity	length in. mm	width in.	width mm	length in.	length mm	lbs.	kg
2124-1-18-16/4	2124-1-18-16/3	21"	533	24"	610	2	18" 457	25"	635	60¼"	1530	99	44.9
2424-1-24-16/4	2424-1-24-16/3	24"	610	24"	610	2	24" 610	28"	711	72¼"	1835	108	49.0

EAGLE GROUP

100 Industrial Boulevard, Clayton, DE 19938-8903 USA

Phone: 302-653-3000 or 800-441-8440 • Fax: 302-653-2065

www.eaglegrp.com • www.eaglegrpnews.com • www.eaglehmc.com

Printed in U.S.A.

©2023 by Eagle Group

Rev. 01/23

Spec sheets available for viewing, printing or downloading from our online literature library at our websites

Although every attempt has been made to ensure the accuracy of the information provided, we cannot be held responsible for typographical or printing errors. Information and specifications are subject to change without notice. Please confirm at time of order.



Profit from the Eagle Advantage®

Specification Sheet

Short Form Specifications

Eagle Two-Compartment Utility Sinks, model _____ . Constructed of type 304 or 430 stainless steel with square corners, Euro-Style edging on front, and 8" backsplash. All partitions have 5/8" rolled top edge. Faucet holes punched on 8" centers. All outside corners to be bullnosed for clean, safe edges. 1 1/2" O.D. galvanized tubular legs with adjustable bullet feet.



two-compartment utility sink

Options / Accessories

- Faucets
- Detachable drainboard *
- Lever waste
- Lever waste with overflow
- Stainless steel legs
- Stainless steel feet

* See Spec Sheet #EG20.13E for optional detachable drainboards.

Design and Construction Features:

- For numerous applications when NSF approval is not required (For NSF-approved utility sinks, add prefix "N-" to model number. Example: N-2460-2-16/3)
- Entire assembly is fuse welded and planished, providing a one-piece seamless sink unit.
- 34 1/2" to 35 1/2" (876 to 902mm) working height.

EAGLE GROUP

100 Industrial Boulevard, Clayton, DE 19938-8903 USA

Phone: 302-653-3000 • Fax: 302-653-2065

www.eaglegrp.com

Foodservice Division: Phone 800-441-8440

MHC/Retail Display Divisions: Phone 800-637-5100

For custom configuration or fabrication needs, contact our SpecFAB® Division.

Phone: 302-653-3000 • Fax: 302-653-2065 • e-mail: quotes@eaglegrp.com

Item No.: _____
 Project No.: _____
 S.I.S. No.: _____

Two-Compartment Utility Sinks with Square Corner Construction

MODELS:

- 1836-2-16/4
- 1836-2-16/3
- 1848-2-16/4
- 1848-2-16/3
- 2136-2-16/4
- 2136-2-16/3
- 2148-2-16/4
- 2148-2-16/3
- 2448-2-16/4
- 2448-2-16/3
- 2460-2-16/4
- 2460-2-16/3
- 2136-2-18-16/4
- 2136-2-18-16/3
- 2448-2-24-16/4
- 2448-2-24-16/3

Top:

- All partitions have euro-style front edge.
- Available with detachable* or welded drainboards.
- 8" (203mm) splash features 2" (51mm) return to wall on 45° angle, with 1" (25mm) upturn.
- 1 1/2" (29mm) faucet holes punched on 8" (203mm) centers.

Legs:

- 1 1/2" (41mm)-diameter heavy-gauge galvanized tubing.
- High-impact corrosion-resistant 1" (25mm) adjustable bullet feet.
- Leg locations fall directly under sink bowls, providing increased stability and maximum weight support.

Sink Bowls:

- 16 gauge type 304 or 430 stainless steel.
- 13 3/4" (340mm)-deep compartments.
- 12-gauge leg gussets welded to a die-cut heavy-gauge reinforcing plate underneath sink bowls.
- Drain holes are 3 1/2" (89mm)-diameter, recessed, and complete with 1 1/2" (38mm) IPS basket-type waste drains, which is shipped loose.

AUTOQUOTES



EG20.13B Rev. 06/14

Spec sheets available for viewing, printing or downloading from our online literature library at www.eaglegrp.com

Eagle Foodservice Equipment, Eagle MHC, SpecFAB®, and Retail Display are divisions of Eagle Group. ©2014 by the Eagle Group



Item No.: _____
 Project No.: _____
 S.I.S. No.: _____

Two-Compartment Utility Sinks with Square Corner Construction

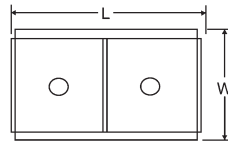
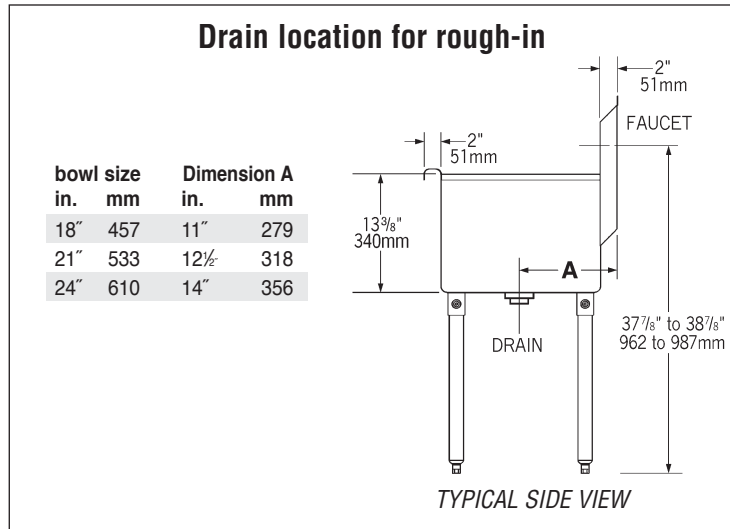

Sinks with No Drainboards

16 gauge type 430 stainless steel model #	16 gauge type 304 stainless steel model #	BOWL DIMENSIONS				DRAINBOARD		OVERALL DIMENSIONS				weight	
		width in.	width mm	length in.	length mm	quantity	length in. mm	width in.	width mm	length in.	length mm	lbs.	kg
1836-2-16/4	1836-2-16/3	18"	457	18"	457	0	n/a	22"	559	37 7/8"	991	75	34.0
1848-2-16/4	1848-2-16/3	18"	457	24"	610	0	n/a	22"	559	49 7/8"	1295	80	36.3
2136-2-16/4	2136-2-16/3	21"	533	18"	457	0	n/a	25"	635	37 7/8"	991	80	36.3
2148-2-16/4	2148-2-16/3	21"	533	24"	610	0	n/a	25"	635	49 7/8"	1295	85	38.6
2448-2-16/4	2448-2-16/3	24"	610	24"	610	0	n/a	28"	711	49 7/8"	1295	89	40.4
2460-2-16/4	2460-2-16/3	24"	610	30"	762	0	n/a	28"	711	61 7/8"	1600	95	43.1

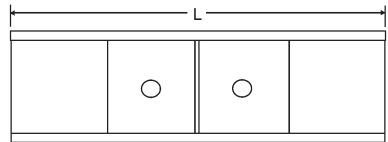

Sinks with Double Drainboards

16 gauge type 430 stainless steel model #	16 gauge type 304 stainless steel model #	BOWL DIMENSIONS				DRAINBOARD		OVERALL DIMENSIONS				weight	
		width in.	width mm	length in.	length mm	quantity	length in. mm	width in.	width mm	length in.	length mm	lbs.	kg
2136-2-18-16/4	2136-2-18-16/3	21"	533	18"	457	2	18" 457	25"	635	72 1/4"	1905	120	54.4
2448-2-24-16/4	2448-2-24-16/3	24"	610	24"	610	2	24" 610	28"	711	96 1/4"	2515	139	63.1

EAGLE GROUP

100 Industrial Boulevard, Clayton, DE 19938-8903 USA

Phone: 302-653-3000 • Fax: 302-653-2065

www.eaglegrp.com

Foodservice Division: Phone 800-441-8440

MHC/Retail Display Divisions: Phone 800-637-5100

Printed in U.S.A.
 ©2014 by Eagle Group

Rev. 06/14

Spec sheets available for viewing, printing or downloading from our online literature library at www.eaglegrp.com

Although every attempt has been made to ensure the accuracy of the information provided, we cannot be held responsible for typographical or printing errors. Information and specifications are subject to change without notice. Please confirm at time of order.



Profit from the Eagle Advantage®

Specification Sheet

Short Form Specifications

Eagle Three-Compartment Utility Sinks, model _____ . Constructed of type 304 or 430 stainless steel with square corners, Euro-Style edging on front, and 8" backsplash. All partitions have 5/8" rolled top edge. Faucet holes punched on 8" centers. All outside corners to be bullnosed for clean, safe edges. 1 1/2" O.D. galvanized tubular legs with adjustable bullet feet.



three-compartment utility sink

Options / Accessories

- Faucets
- Detachable drainboard *
- Lever waste
- Lever waste with overflow
- Stainless steel legs
- Stainless steel feet

* See Spec Sheet #EG20.13E for optional detachable drainboards.

Design and Construction Features:

- For numerous applications when NSF approval is not required (For NSF-approved utility sinks, add prefix "N-" to model number. Example: N-2460-3-16/3)
- Entire assembly is fuse welded and planished, providing a one-piece seamless sink unit.
- 34 1/2" to 35 1/2" (876 to 902mm) working height.

EAGLE GROUP

100 Industrial Boulevard, Clayton, DE 19938-8903 USA

Phone: 302-653-3000 • Fax: 302-653-2065

www.eaglegrp.com

Foodservice Division: Phone 800-441-8440

MHC/Retail Display Divisions: Phone 800-637-5100

For custom configuration or fabrication needs, contact our SpecFAB® Division.

Phone: 302-653-3000 • Fax: 302-653-2065 • e-mail: quotes@eaglegrp.com

Item No.: _____
 Project No.: _____
 S.I.S. No.: _____

Three-Compartment Utility Sinks with Square Corner Construction

MODELS:

- 1836-3-16/4
- 1836-3-16/3
- 1848-3-16/4
- 1848-3-16/3
- 1854-3-16/4
- 1854-3-16/3
- 2136-3-16/3
- 2148-3-16/4
- 2148-3-16/3
- 2154-3-16/4
- 2154-3-16/3
- 2160-3-16/4
- 2160-3-16/3
- 2448-3-16/4
- 2448-3-16/3
- 2460-3-16/4
- 2472-3-16/4
- 2472-3-16/3
- 2136-3-18-16/3
- 2148-3-18-16/4
- 2148-3-18-16/3
- 2154-3-18-16/4
- 2154-3-18-16/3
- 2472-3-24-16/4
- 2472-3-24-16/3

Top:

- All partitions have euro-style front edge.
- Available with detachable* or welded drainboards.
- 8" (203mm) splash features 2" (51mm) return to wall on 45° angle, with 1" (25mm) upturn.
- 1 1/8" (29mm) faucet holes punched on 8" (203mm) centers.

Legs:

- 1 1/2" (41mm)-diameter heavy-gauge galvanized tubing.
- High-impact corrosion-resistant 1" (25mm) adjustable bullet feet.
- Leg locations fall directly under sink bowls, providing increased stability and maximum weight support.

Sink Bowls:

- 16 gauge type 304 or 430 stainless steel.
- 13 3/4" (340mm)-deep compartments.
- 12-gauge leg gussets welded to a die-cut heavy-gauge reinforcing plate underneath sink bowls.
- Drain hole is 3 1/2" (89mm)-diameter recessed and complete with 1 1/2" (38mm) IPS basket-type waste drain, which is shipped loose.

AUTOQUOTES



EG20.13C Rev. 06/14

Spec sheets available for viewing, printing or downloading from our online literature library at www.eaglegrp.com

Eagle Foodservice Equipment, Eagle MHC, SpecFAB®, and Retail Display are divisions of Eagle Group. ©2014 by the Eagle Group



Item No.: _____
 Project No.: _____
 S.I.S. No.: _____

Three-Compartment Utility Sinks with Square Corner Construction

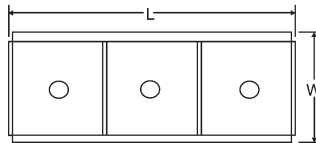
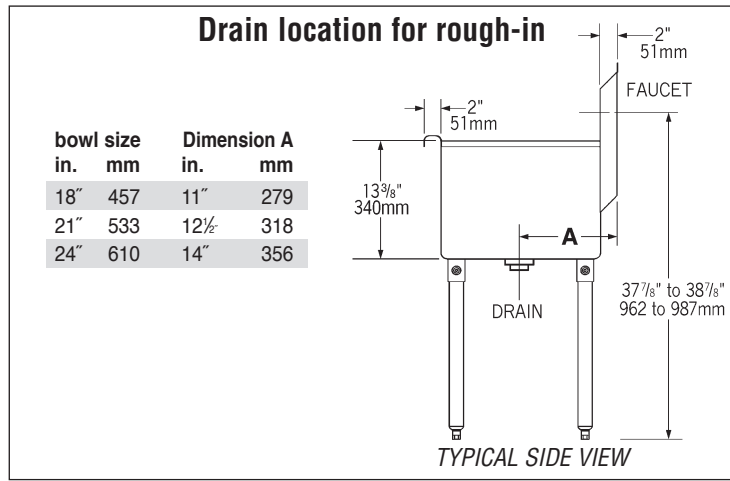

Sinks with No Drainboards

16 gauge type 430 stainless steel model #	16 gauge type 304 stainless steel model #	BOWL DIMENSIONS				DRAINBOARD		OVERALL DIMENSIONS				weight	
		width in.	width mm	length in.	length mm	quantity	length in. mm	width in.	width mm	length in.	length mm	lbs.	kg
1836-3-16/4	1836-3-16/3	18"	457	12"	305	0	n/a	22"	559	37 3/8"	949	79	35.8
1848-3-16/4	1848-3-16/3	18"	457	16"	406	0	n/a	22"	559	49 3/8"	1254	90	40.8
1854-3-16/4	1854-3-16/3	18"	457	18"	457	0	n/a	22"	559	55 3/8"	1406	97	44.0
2136-3-16/4	2136-3-16/3	21"	533	12"	305	0	n/a	25"	635	37 3/8"	949	85	38.6
2148-3-16/4	2148-3-16/3	21"	533	16"	406	0	n/a	25"	635	49 3/8"	1254	87	39.5
2154-3-16/4	2154-3-16/3	21"	533	18"	457	0	n/a	25"	635	55 3/8"	1406	100	45.4
2160-3-16/4*	2160-3-16/3*	21"	533	20"	508	0	n/a	25"	635	61 3/8"	1559	110	49.9
2448-3-16/4	2448-3-16/3	24"	610	16"	406	0	n/a	28"	711	49 3/8"	1254	92	41.7
2460-3-16/4*	2460-3-16/3*	24"	610	20"	508	0	n/a	28"	711	61 3/8"	1559	115	52.2
2472-3-16/4*	2472-3-16/3*	24"	610	24"	610	0	n/a	28"	711	73 3/8"	1864	125	56.7

* Includes two sets of faucet holes.

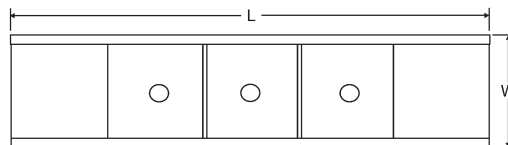

Sinks with Double Drainboards

16 gauge type 430 stainless steel model #	16 gauge type 304 stainless steel model #	BOWL DIMENSIONS				DRAINBOARD		OVERALL DIMENSIONS				weight	
		width in.	width mm	length in.	length mm	quantity	length in. mm	width in.	width mm	length in.	length mm	lbs.	kg
2136-3-18-16/4	2136-3-18-16/3	21"	533	12"	305	2	18" 457	25"	635	72 1/4"	1835	125	56.7
2148-3-18-16/4	2148-3-18-16/3	21"	533	16"	406	2	18" 457	25"	635	84 1/4"	2140	127	57.6
2154-3-18-16/4	2154-3-18-16/3	21"	533	18"	457	2	18" 457	25"	635	90 1/4"	2292	140	63.5
2472-3-24-16/4*	2472-3-24-16/3*	24"	610	24"	610	2	24" 610	28"	711	120 1/4"	3054	175	79.4

* Includes two sets of faucet holes.

EAGLE GROUP
 100 Industrial Boulevard, Clayton, DE 19938-8903 USA
 Phone: 302-653-3000 • Fax: 302-653-2065
 www.eaglegrp.com

Foodservice Division: Phone 800-441-8440
 MHC/Retail Display Divisions: Phone 800-637-5100

Printed in U.S.A.
 ©2014 by Eagle Group

Rev. 06/14

Spec sheets available for viewing, printing or downloading from our online literature library at www.eaglegrp.com

Although every attempt has been made to ensure the accuracy of the information provided, we cannot be held responsible for typographical or printing errors. Information and specifications are subject to change without notice. Please confirm at time of order.



Profit from the Eagle Advantage®

Specification Sheet

Short Form Specifications

Eagle Four-Compartment Utility Sinks, model _____ . Constructed of type 304 or 430 stainless steel with square corners, Euro-Style edging on front, and 8" backsplash. All partitions have 5/8" rolled top edge. Faucet holes punched on 8" centers (set of two). All outside corners to be bullnosed for clean, safe edges. 1 1/2" O.D. galvanized tubular legs with adjustable bullet feet.



four-compartment utility sink

Options / Accessories

- Faucets
- Detachable drainboard *
- Lever waste
- Lever waste with overflow
- Stainless steel legs
- Stainless steel feet

* See Spec Sheet #EG20.13E for optional detachable drainboards.

Design and Construction Features:

- For numerous applications when NSF approval is not required (For NSF-approved utility sinks, add prefix "N-" to model number. Example: N-2460-2-16/3)
- Entire assembly is fuse welded and planished, providing a one-piece seamless sink unit.
- 34 1/2" to 35 1/2" (876 to 902mm) working height.

EAGLE GROUP

100 Industrial Boulevard, Clayton, DE 19938-8903 USA

Phone: 302-653-3000 • Fax: 302-653-2065

www.eaglegrp.com

Foodservice Division: Phone 800-441-8440

MHC/Retail Display Divisions: Phone 800-637-5100

For custom configuration or fabrication needs, contact our SpecFAB® Division.

Phone: 302-653-3000 • Fax: 302-653-2065 • e-mail: quotes@eaglegrp.com

Item No.: _____
 Project No.: _____
 S.I.S. No.: _____

Four-Compartment Utility Sinks with Square Corner Construction

MODELS:

- 1872-4-16/4
- 1872-4-16/3
- 2172-4-16/4
- 2172-4-16/3
- 2472-4-16/4
- 2472-4-16/3
- 2172-4-18-16/4
- 2172-4-18-16/3

Top:

- All partitions have euro-style front edge.
- Available with detachable* or welded drainboards.
- 8" (203mm) splash features 2" (51mm) return to wall on 45° angle, with 1" (25mm) upturn.
- Set of two 1 1/2" (29mm) faucet holes punched on 8" (203mm) centers.

Legs:

- 1 1/2" (41mm)-diameter heavy-gauge galvanized tubing.
- High-impact corrosion-resistant 1" (25mm) adjustable bullet feet.
- Leg locations fall directly under sink bowls, providing increased stability and maximum weight support.

Sink Bowls:

- 16 gauge type 304 or 430 stainless steel.
- 13 3/4" (340mm)-deep compartments.
- 12-gauge leg gussets welded to a die-cut heavy-gauge reinforcing plate underneath sink bowls.
- Drain holes are 3 1/2" (89mm)-diameter, recessed, and complete with 1 1/2" (38mm) IPS basket-type waste drains, which is shipped loose.

AUTOQUOTES



EG20.13D Rev. 06/14

Spec sheets available for viewing, printing or downloading from our online literature library at www.eaglegrp.com

Eagle Foodservice Equipment, Eagle MHC, SpecFAB®, and Retail Display are divisions of Eagle Group. ©2014 by the Eagle Group



Item No.: _____
 Project No.: _____
 S.I.S. No.: _____

Four-Compartment Utility Sinks with Square Corner Construction

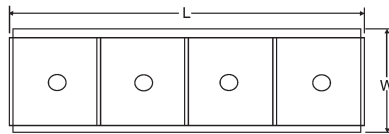
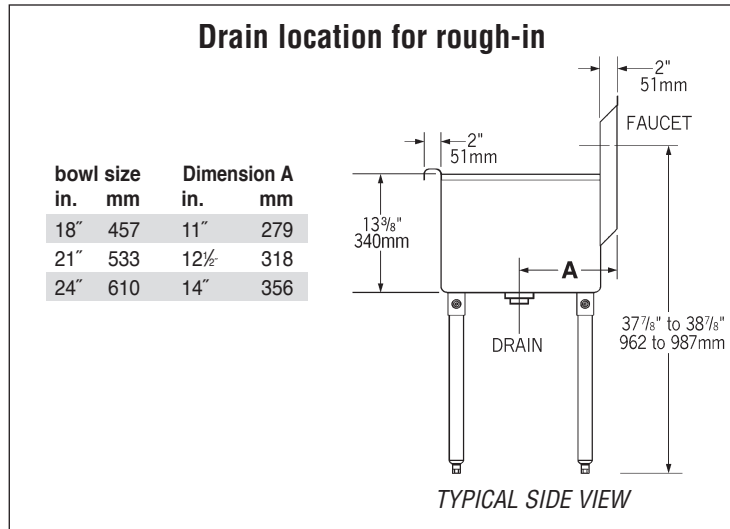

Sinks with No Drainboards

16 gauge type 430 stainless steel model #	16 gauge type 304 stainless steel model #	BOWL DIMENSIONS				DRAINBOARD		OVERALL DIMENSIONS				weight	
		width in.	width mm	length in.	length mm	quantity	length in. mm	width in.	width mm	length in.	length mm	lbs.	kg
1872-4-16/4	1872-4-16/3	18"	457	18"	457	0	n/a	22"	559	73 3/4"	1864	110	49.9
2172-4-16/4	2172-4-16/3	21"	533	18"	457	0	n/a	25"	635	73 3/4"	1864	115	52.2
2472-4-16/4	2472-4-16/3	24"	610	18"	457	0	n/a	28"	711	73 3/4"	1864	125	56.7

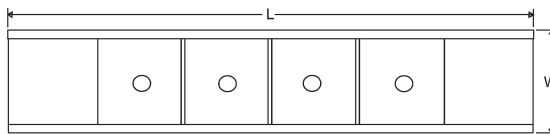

Sinks with Double Drainboards

16 gauge type 430 stainless steel model #	16 gauge type 304 stainless steel model #	BOWL DIMENSIONS				DRAINBOARD		OVERALL DIMENSIONS				weight	
		width in.	width mm	length in.	length mm	quantity	length in. mm	width in.	width mm	length in.	length mm	lbs.	kg
2172-4-18-16/4	2172-4-18-16/3	21"	533	18"	457	2	18" 457	25"	635	108 1/4"	2750	155	70.3

EAGLE GROUP
 100 Industrial Boulevard, Clayton, DE 19938-8903 USA
 Phone: 302-653-3000 • Fax: 302-653-2065
 www.eaglegrp.com

Foodservice Division: Phone 800-441-8440
 MHC/Retail Display Divisions: Phone 800-637-5100

Printed in U.S.A.
 ©2014 by Eagle Group
 Rev. 06/14

Spec sheets available for viewing, printing or downloading from our online literature library at www.eaglegrp.com

Although every attempt has been made to ensure the accuracy of the information provided, we cannot be held responsible for typographical or printing errors. Information and specifications are subject to change without notice. Please confirm at time of order.