

INSTALLATION INSTRUCTIONS

CAUTION

INSPECT CONTENTS IMMEDIATELY AND FILE CLAIM WITH DELIVERING CARRIER FOR ANY DAMAGE.
SAVE YOUR BOX AND ALL PACKING MATERIALS.
YOU ARE RESPONSIBLE FOR DAMAGE TO YOUR UNIT IF RETURNED IMPROPERLY PACKED.

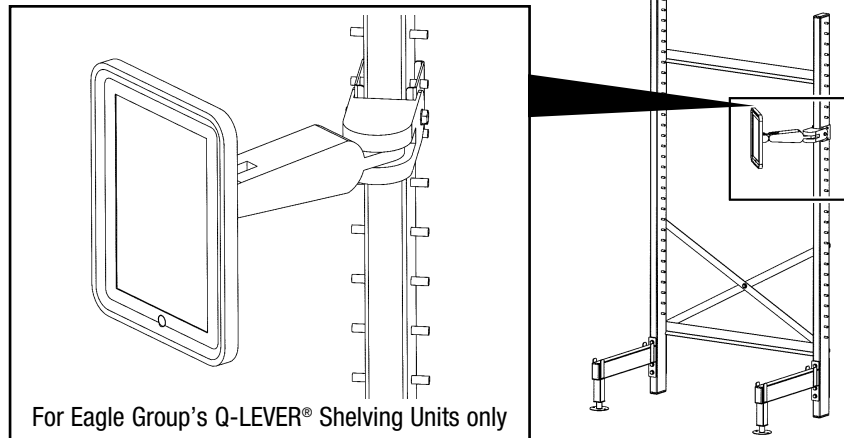

Step 1 - Hang brackets on pegs of upright.

- Choose left or right upright.
- Place brackets over pegs at desired height, as shown below.

IMPORTANT: Make sure the welded-in nut, on the back side of each bracket, is positioned toward the FRONT of shelving unit.

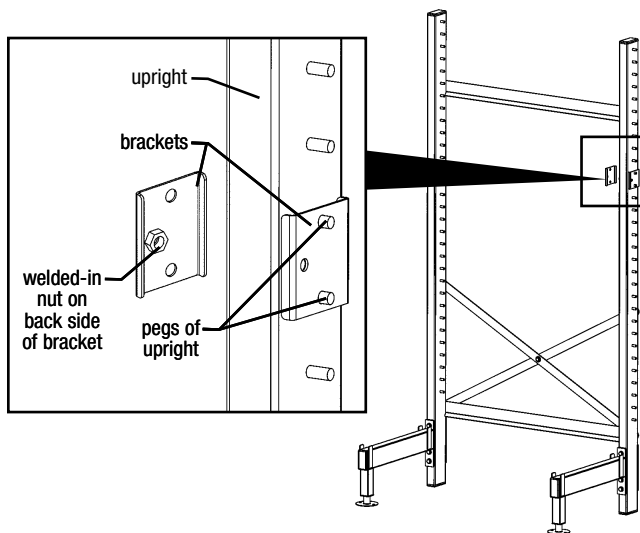

Step 2 - Affix monitor arm to brackets.

- Align holes on monitor arm to holes on brackets, as shown below.
- On each side of monitor arm, secure with 5/16" lock washer and 5/16"-18x1/2" hex head bolt provided.

