



Profit from the Eagle Advantage®

Phone: (800) 441-8440 • (302) 653-3000

FAX: (302) 653-2065

# Product Announcement

## Short Form Specifications

Eagle Foot Rest, model #FR-1221-SS. Heavy gauge stainless steel all-welded construction. Cantilever-style design. Platform is adjustable on 1½" centers, ranging from 4½" to 9¾" at the lower leading edge to the floor. 1"-square tubular welded frame. ¾"-high non-slip rubber feet.

Item #:	_____
Model #:	_____
Project #:	_____
SIS #:	_____

EG8224 Rev. 09/21

## New Foot Rest

### Design & Construction

#### Features:

- Heavy gauge stainless steel all-welded construction.
- 1" square tubular welded frame.
- Slotted uprights with rubber caps.
- Platform set at 12° angle.
- Adjustable on 1½" centers, ranging from 4½" to 9¾" at the lowest leading edge to the floor.
- Non-slip rubber feet.
- 13" height.
- Designed with stress relief in mind.



#FR-1221-SS

*The FR-1221-SS stainless steel adjustable ergonomic foot rest can help enhance comfort and performance and reduce physical stress, while the user is sitting or standing. Durable construction will deliver comfort for years to come. Ideal for use in the office environment, cleanrooms, labs, healthcare facilities, any place where long periods of sitting is requiring.*

For custom configuration or fabrication needs, contact our **SpecFAB® Division**.

Phone: (302) 653-3000. FAX: (302) 653-2065.

E-mail: [quotes@eaglegrp.com](mailto:quotes@eaglegrp.com)



# Foot Rest

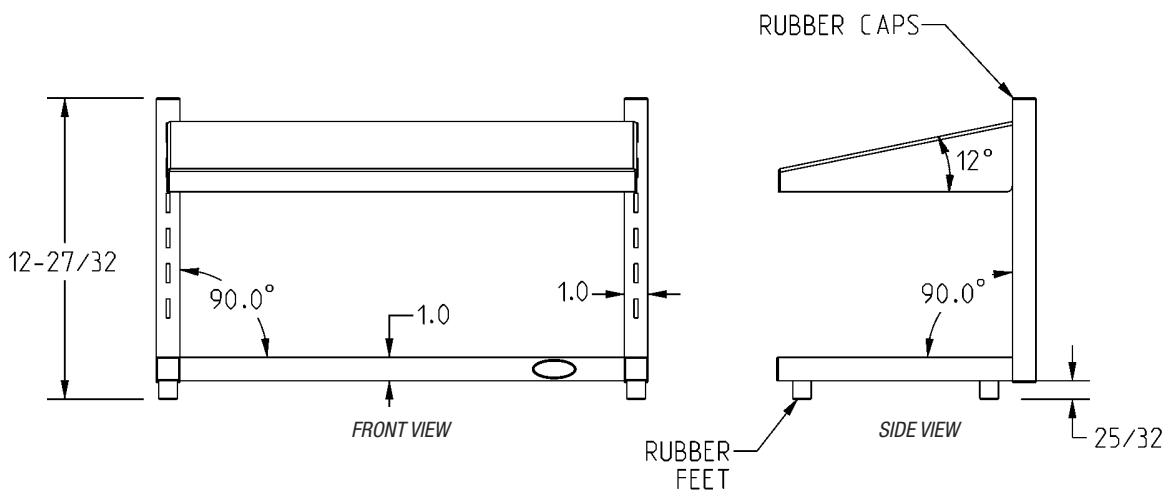
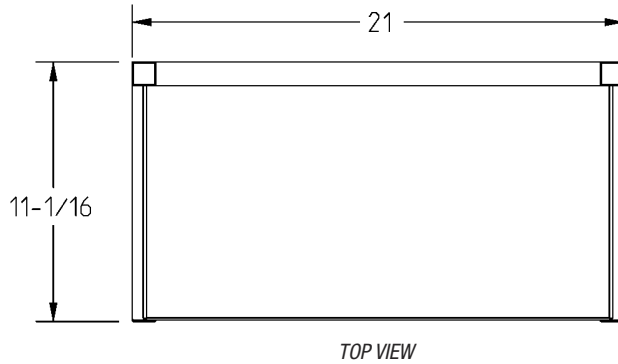

length		width		height		model #
in.	mm	in.	mm	in.	mm	
21"	533	11 <sup>1</sup> / <sub>16</sub> "	281	12 <sup>7</sup> / <sub>16</sub> "	327	FR-1221-SS