



Profit from the Eagle Advantage®

# Specification Sheet

## Short Form Specifications

Eagle Stainless Steel Caster Cradle® caster stabilizing device, model # \_\_\_\_\_. For stabilizing mobile equipment and correct placement under fire system nozzles. Unique bowl shaped design allows for accurate placement of mobile equipment every time. Units are secured to the floor where the casters are to be centered.

Item No.:	_____
Project No.:	_____
S.I.S. No.:	_____

# Stainless Steel Caster Cradle® Stabilizing Device

### MODELS:

- CC-S-2
- CC-S-10
- CC-S-60

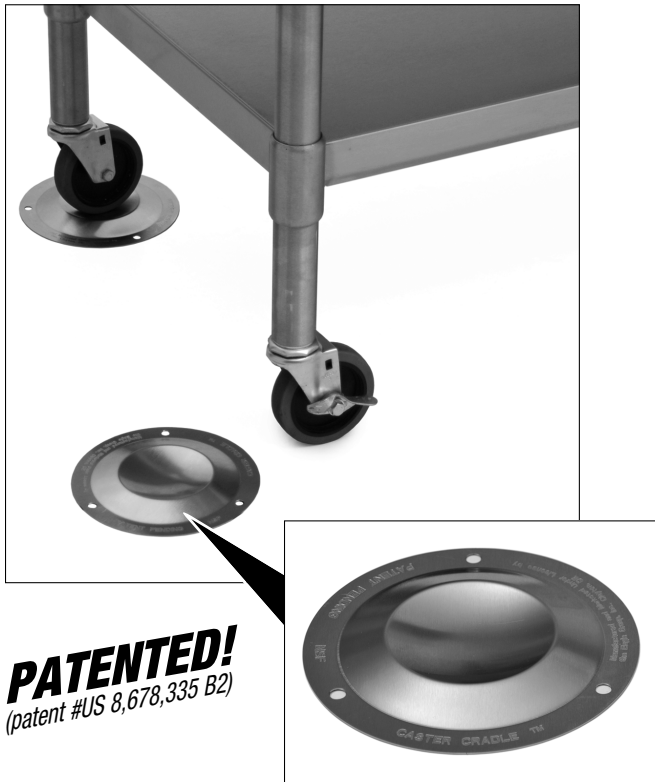

### Design and Construction Features

- For stabilization of mobile equipment and correct placement under fire system nozzles, using a set of two (typically), placed at rear wheels of equipment with front locking casters.
- When the caster wheel enters anywhere along the edge of the caster cradle, gravity will cause it to drop automatically to the direct center, assuring exact placement of mobile equipment every time.
- Low profile design allows for easy movement of equipment caster into the contoured center.
- Circular design allows approach from any angle, making equipment alignment easy.
- Easy installation in any existing kitchen.
- Works with casters up to 8" (203mm)-diameter.
- Heavy gauge stainless steel.
- Can be used to keep any mobile equipment properly aligned throughout the facilities.

**EAGLE GROUP**  
 100 Industrial Boulevard  
 Clayton, DE 19938-8903 USA  
 Phone: 302-653-3000 • 800-441-8440  
 Fax: 302-653-2065  
 www.eaglegrp.com • www.eaglemhc.com

For custom configuration or fabrication needs, contact our **SpecFAB® Division**.  
 Phone: 302-653-3000 • Fax: 302-653-2065 • e-mail: quotes@eaglegrp.com



EG10.05M Rev. 05/22

**Spec sheets available for viewing, printing or downloading from our online literature library at [www.eaglegrp.com](http://www.eaglegrp.com)**

*Eagle Foodservice Equipment, Eagle MHC, and SpecFAB® are divisions of Eagle Group. ©2022 by the Eagle Group*



Item No.: \_\_\_\_\_  
 Project No.: \_\_\_\_\_  
 S.I.S. No.: \_\_\_\_\_

# Stainless Steel Caster Cradle® Stabilizing Device

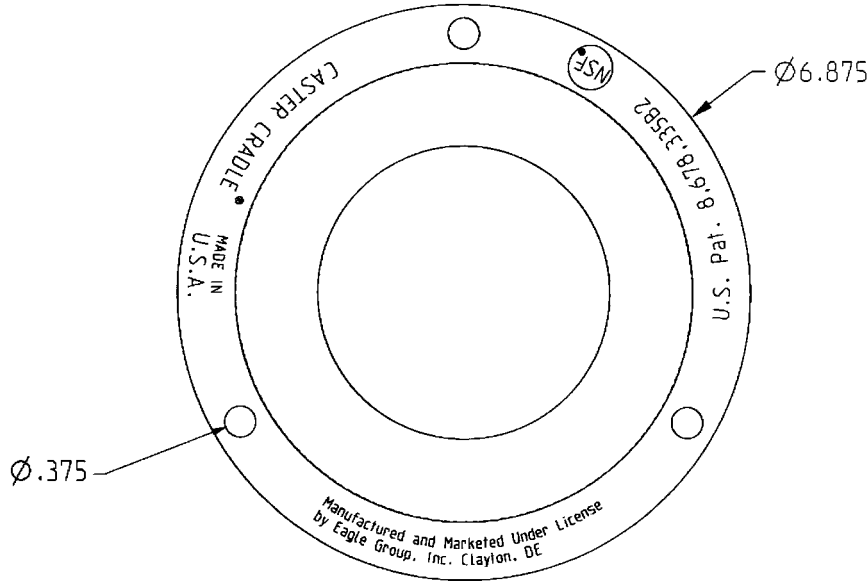

TOP VIEW

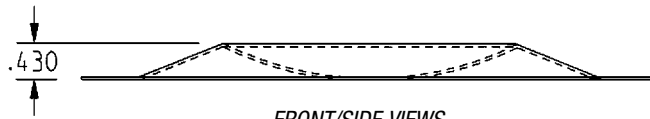

FRONT/SIDE VIEWS

model #	description	weight	
		lbs.	kg
CC-S-2	quantity of two per package	1	0.5
CC-S-10	quantity of 10 per package	4	1.8
CC-S-60	quantity of 60 per package	23	10.4

**EAGLE GROUP**  
 100 Industrial Boulevard, Clayton, DE 19938-8903 USA  
 Phone: 302-653-3000 or 800-441-8440 • Fax: 302-653-2065  
 www.eaglegrp.com • www.eaglemhc.com

Printed in U.S.A.  
 ©2022 by Eagle Group  
 Rev. 05/22

Spec sheets available for viewing, printing or downloading from our online literature library at [www.eaglegrp.com](http://www.eaglegrp.com)

Although every attempt has been made to ensure the accuracy of the information provided, we cannot be held responsible for typographical or printing errors. Information and specifications are subject to change without notice. Please confirm at time of order.