

# Double Gowning Rack

## ASSEMBLY INSTRUCTIONS

### CAUTION

INSPECT CONTENTS IMMEDIATELY AND FILE CLAIM WITH DELIVERING CARRIER FOR ANY DAMAGE.  
**SAVE YOUR BOX AND ALL PACKING MATERIALS.** YOU ARE RESPONSIBLE FOR DAMAGE TO YOUR UNIT IF RETURNED IMPROPERLY PACKED.

### Fasteners

Item #	quantity	description	part #
#1	12	1/4"-16 x 3/4" Hex Bolt	306138
#2	12	3/8" Flat Washer	305010
#3	4	3/8" Nylon Stem Glide	316996
#4 *	3	1/4"-20 x 3/4" Carriage Bolt	333386
#5 *	3	1/4" Split Washer	312597
#6 *	3	1/4"-20 Hex Nut	312079

\* For non-removable-hanger models only (see Step 5)

**Tools required for assembly:** 1/4" socket wrench, 3/8" socket wrench, adjustable open-end wrench

*Before assembly, attach any loose plastic caps onto each end of tubing on post assemblies.*

### Step 1 - Attach glides to post assemblies.

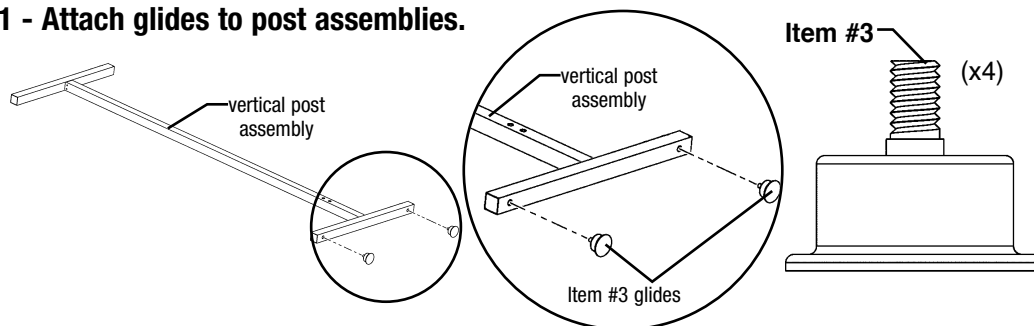

### Step 2 - Attach horizontal support bars to post assemblies.

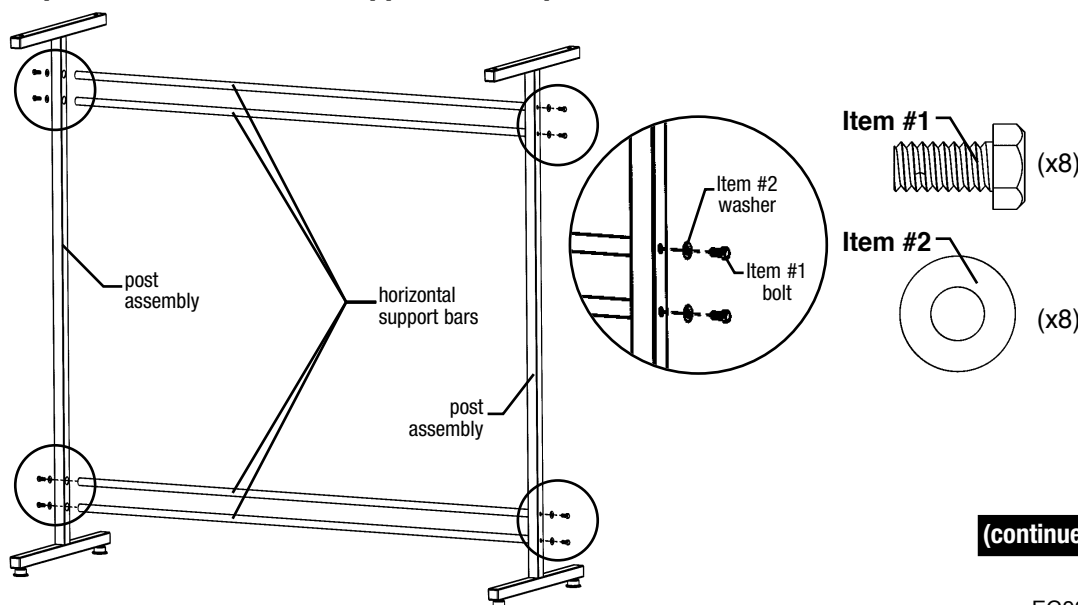

**(continued on back page)**

EG9881 Revised 07/22

# Double Gowning Rack

## ASSEMBLY INSTRUCTIONS

### Step 3 - Attach hanger rails.

Do not tighten bolts yet.

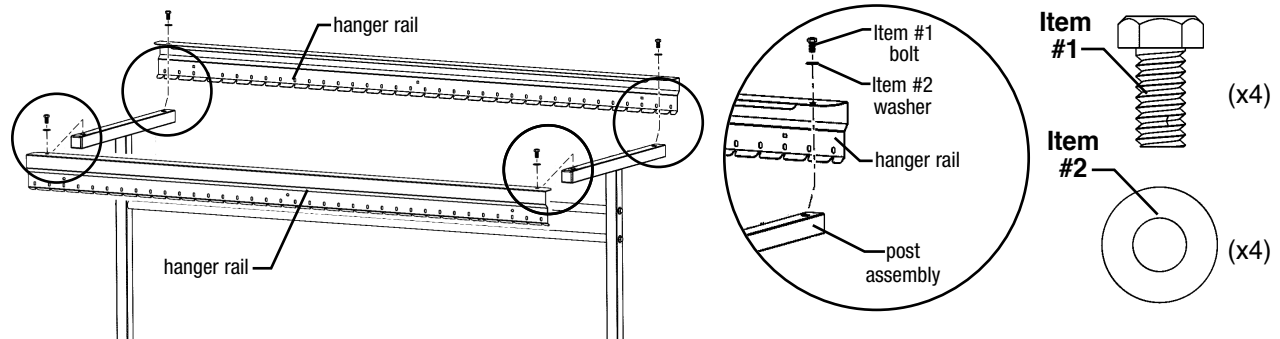

### Step 4 - Install hangers.

Insert hangers (not included) into desired slots on hanger rail(s).

If your unit has removable hangers and does not include keeper bars, then tighten Item #1 bolts on hanger rails.

**(End)** Assembly is complete.

*If your unit has keeper bars (for non-removable hangers), go to **Step 5** below.*

### Step 5 - Attach keeper bars to rear side of hanger rails.

Attach keeper bars using Item #4 bolts, Item #5 washers and Item #6 nuts.

Tighten hardware.

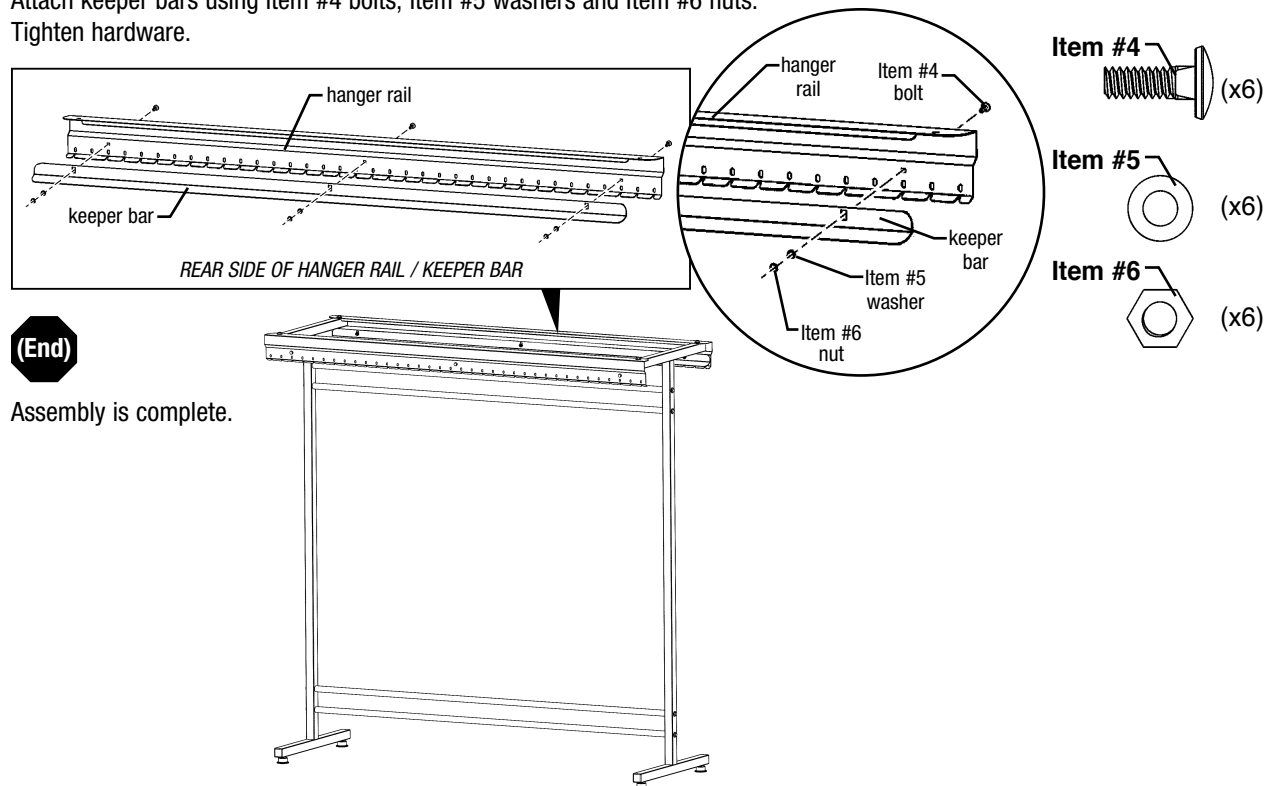

**(End)** Assembly is complete.