

Modular Desks/Workstations

ASSEMBLY INSTRUCTIONS

CAUTION

INSPECT CONTENTS IMMEDIATELY AND FILE CLAIM WITH DELIVERING CARRIER FOR ANY DAMAGE. **SAVE YOUR BOX AND ALL PACKING MATERIALS.** YOU ARE RESPONSIBLE FOR DAMAGE TO YOUR UNIT IF RETURNED IMPROPERLY PACKED.

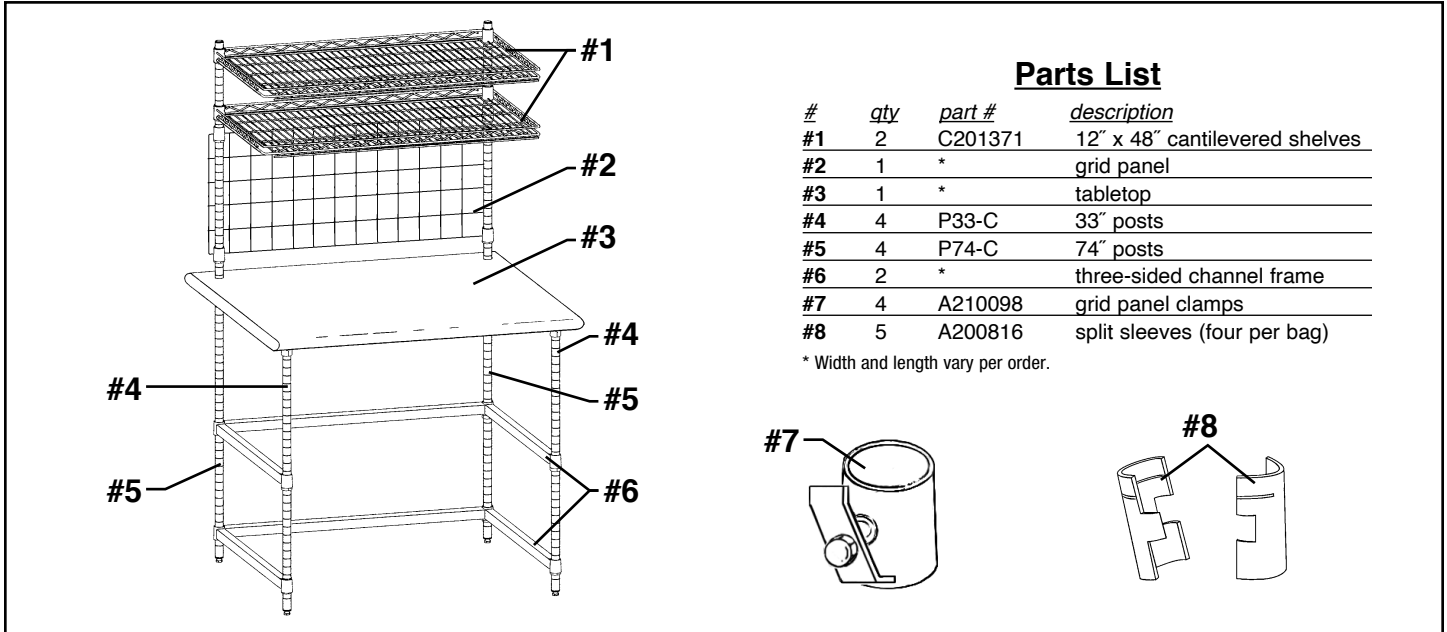

Parts List

#	qty	part #	description
#1	2	C201371	12" x 48" cantilevered shelves
#2	1	*	grid panel
#3	1	*	tabletop
#4	4	P33-C	33" posts
#5	4	P74-C	74" posts
#6	2	*	three-sided channel frame
#7	4	A210098	grid panel clamps
#8	5	A200816	split sleeves (four per bag)

* Width and length vary per order.

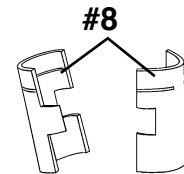
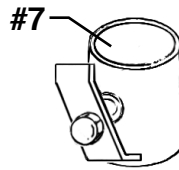

Step 1 - Attach bottom channel frame to posts.

Snap split sleeve onto each post at the #3 groove (the wider part of the taper goes toward the bottom).

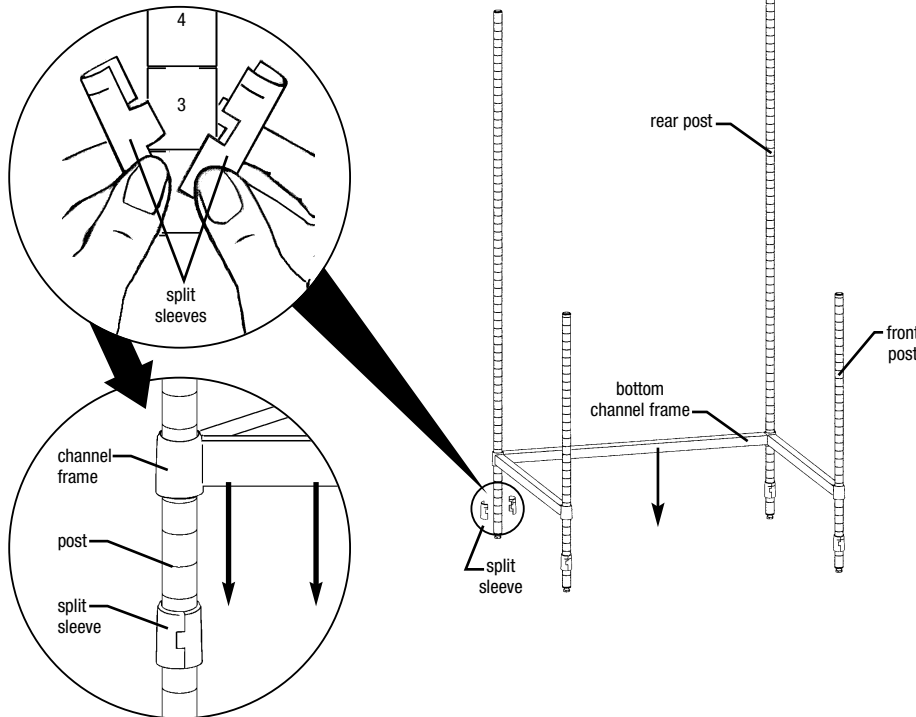

Step 2 - Attach top channel frame to posts.

Repeat **Step 1**, attaching split sleeve onto each post at the desired groove.

(continued on Page 2)

EG10068 Revised 12/22

Modular Desks/Workstations

ASSEMBLY INSTRUCTIONS

Step 3 - Attach tabletop.

Snap split sleeve onto each post at the #33 groove.

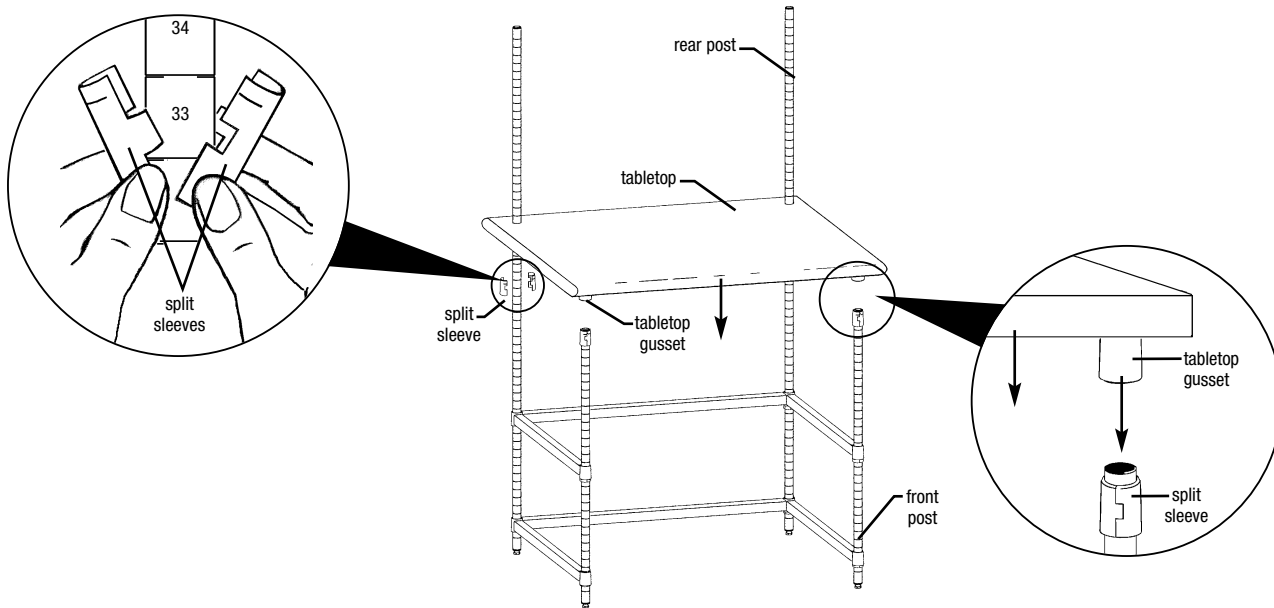

Step 4 - Attach grid panel clamps.

- Snap split sleeves onto desired groove on rear posts.
- Lower grid panel clamps onto split sleeves, making sure clamps are facing toward rear.
- Count 15 grooves up and place split sleeve for the top of the grid panel.
- Lower grid panel clamps onto split sleeves, making sure clamps are facing toward rear.

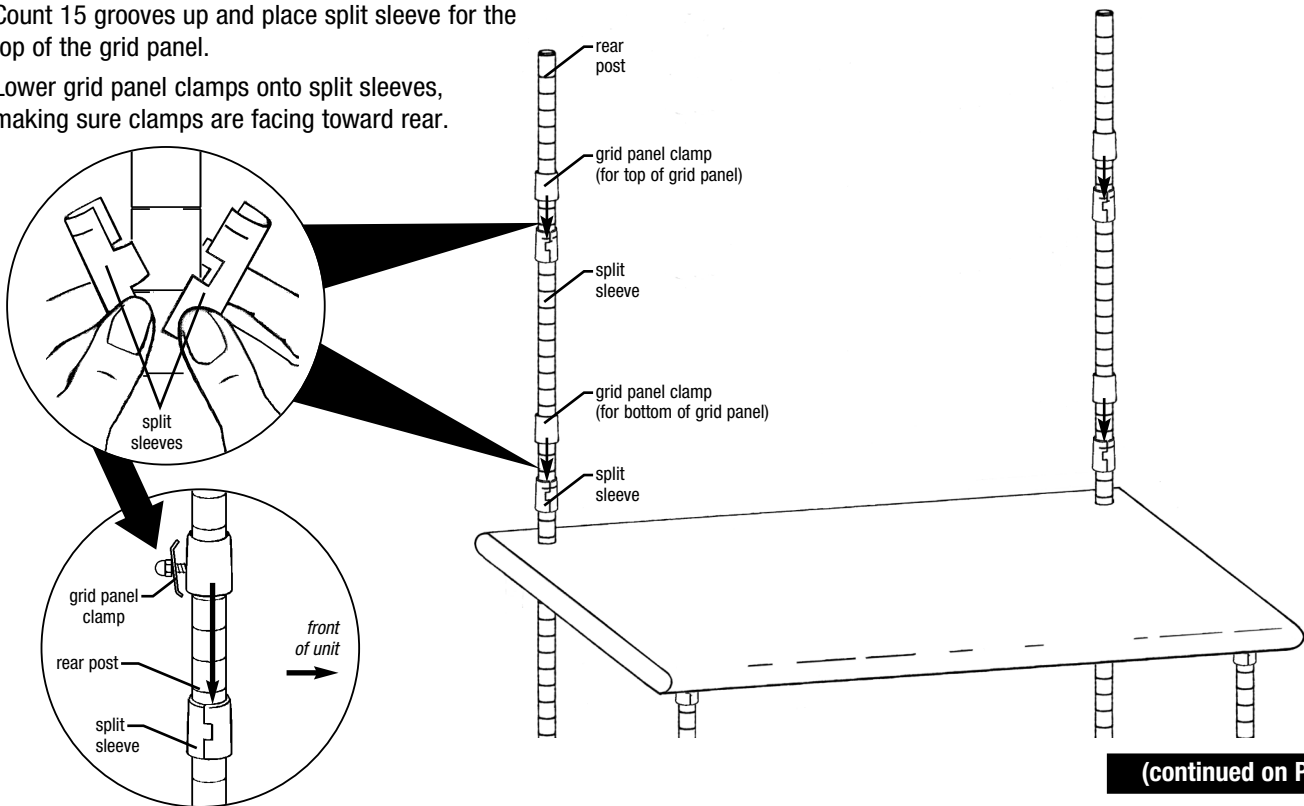

(continued on Page 3)

Modular Desks/Workstations

ASSEMBLY INSTRUCTIONS

Step 5 - Attach grid panel.

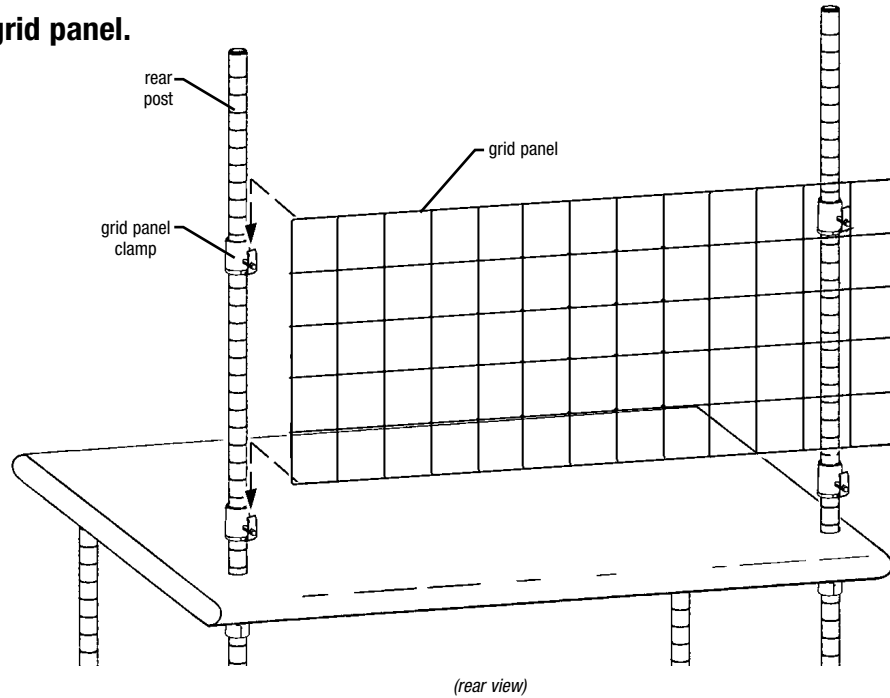

Step 6 - Attach cantilevered shelves.

- Snap split sleeves onto desired groove on rear posts.
- Lower bottom cantilevered shelf onto split sleeves.
- Snap split sleeves onto top groove on rear posts.
- Lower top cantilevered shelf onto split sleeves.

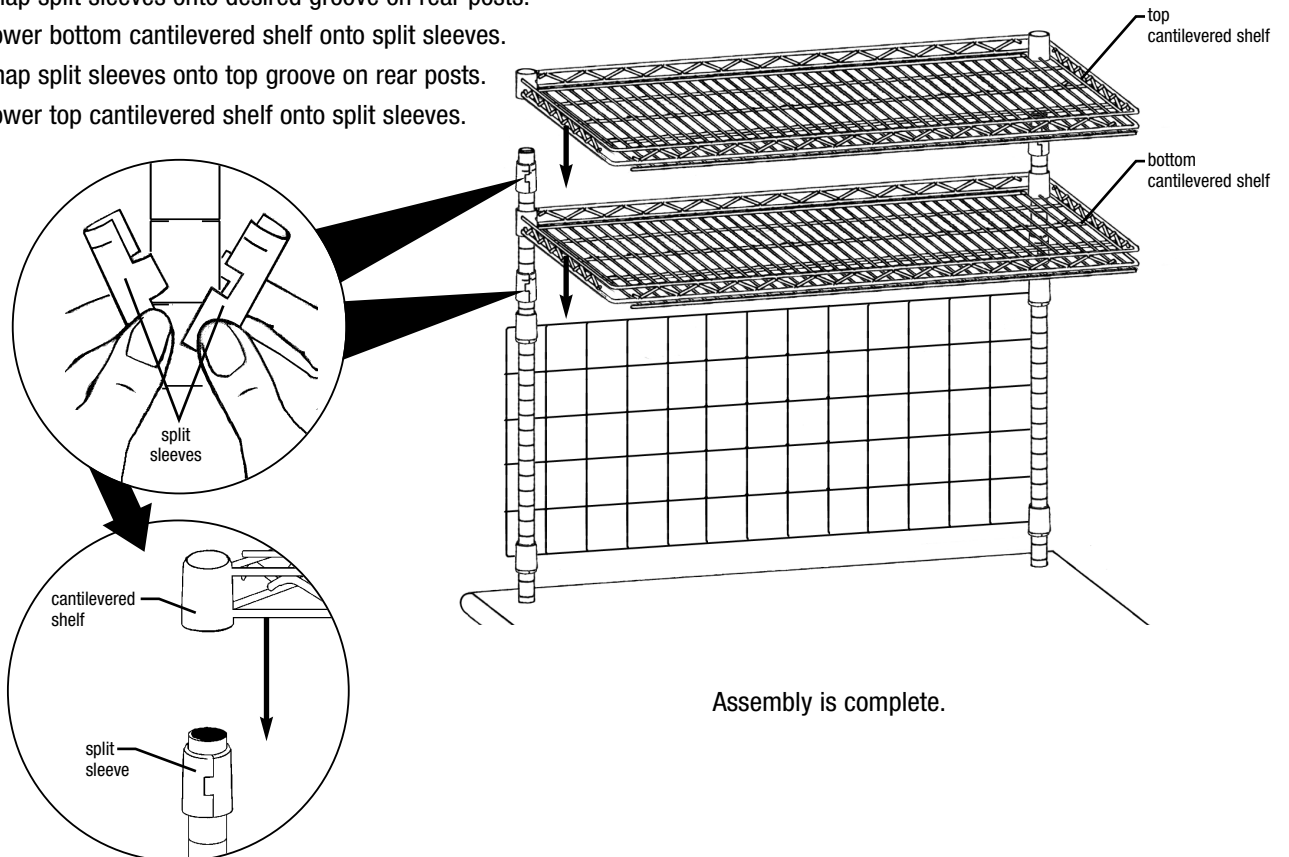

(End)

Modular Desks/Workstations

WARRANTY

Eagle Shelving Warranty

Eagle warrants that the goods supplied hereunder manufactured by Eagle will be free from defects in material and workmanship for 1 year from shipment from our factory. In addition, our shelving also carries a warranty against corrosion and rust formation for the timeframes outlined below(chart). Upon factory review, we guarantee to replace any part, provided it has been properly installed and maintained. If a shelf proves to be defective, or not in conformity with the specification, customers are entitled only to replacement of such unit. Under no circumstances will Eagle be liable for labor or subsequent damage.

<i>Finish</i>	<i>Warranty</i>	<i>Storage Conditions</i>	<i>Proration</i>
Chrome	1-YEAR WARRANTY	Dry Storage	*90 days at no cost, 5% for each 30 days thereafter, 1+ yr 100%
EAGLEbrite®	3-YEAR WARRANTY	Dry Storage	*1 year no cost, 20% for year 2 and 5% for each completed year thereafter, 3+ yr 100%
VALU-MASTER®	5-YEAR LIMITED WARRANTY*	Wet & Dry Storage	*1-2 yr no cost, 20% for year 3 and 5% for each completed year thereafter, 5+ yr 100%
Valu-Gard®	5-YEAR LIMITED WARRANTY*	Wet & Dry Storage	*1-2 yr no cost, 20% for year 3 and 5% for each completed year thereafter, 5+ yr 100%
EAGLEgard® (with MICROGARD®)	12-YEAR LIMITED WARRANTY*	Wet & Dry Storage	*1-5 yr no cost, 20% for year 6 plus 5% for each completed year thereafter, 12+ yr 100%
Stainless Steel	15-YEAR LIMITED WARRANTY*	Wet & Dry Storage	*1-5 yr no cost, 20% for year 6 plus 5% for each completed year thereafter, 15+ yr 100%
QuadPLUS®	*	Wet & Dry Storage	None
*Polymer shelf mats have a lifetime warranty against rust and corrosion. *Wire truss frames, based on finish, share warranty duration as outlined above. *Note frame defaults to finish warranty above. *Frame finish prorates by above chart, based on finish.			
Solid Shelving - Stainless	1-YEAR WARRANTY	Wet & Dry Storage	None
Solid Shelving - Galvanized	1-YEAR WARRANTY	Dry Storage	*90 days at no cost, 5% for each 30 days thereafter, 1+ yr 100%

* Replacement cost of prorated amounts will be determined based on original order value and will be applied as a credit for warranty replacement orders.

- Replacements are covered only for the balance of the original order's warranty timeframe.
- Replacement quantities cannot exceed quantities originally purchased over the duration of the warranty period.
- Eagle may request evidence of disposal for original items replaced under warranty claims.

Eagle wire shelving must be cleaned with soft cloths and mild detergent. Using harsh detergents, abrasive materials, scrapers or stiff brushes will void this warranty. In addition, any physical damage, rupturing the coating, or sustained exposure to corrosive substances and vapors is not covered. Warranty applies only when shelves have been continuously used within a temperature range from -20°F to +120°F, with intermittent exposure up to +200°F for Valu-Gard, Valu-Master or EAGLEgard epoxy finishes, and up to +175°F for chrome or EAGLEbrite zinc finishes. The customer agrees to use only cleaners that are recommended for use on epoxy-coated steel. Eagle plated shelving finishes are not intended for use in an automated cart wash system and such use will invalidate the warranty. In the event of a warranty claim, an Eagle representative will review the claim and provide disposition. A shelf may need to be returned for inspection and testing to determine if a claim can be paid. Returns, including disassembly and subsequent reassembly, become the responsibility of the initial owner. If it is found after outside testing that the issue came from misuse, neglect, or failure to follow cleaning guidelines the cost of testing may be charged back to the customer.

**CLICK HERE to review
full warranty information**



- 100 Industrial Boulevard, Clayton, Delaware 19938-8903 U.S.A.
- Phone: 302/653-3000 • 800/441-8440 • Fax: 302/653-2065
- www.eaglegrp.com • www.eaglegrpnews.com • www.eaglemhc.com