



Profit from the Eagle Advantage®

# Specification Sheet

## Short Form Specifications

Bulk storage configuration in 48" or 60" length by 24" width by 69" height. Chrome plated. Four hanger bars with 32 hooks on 48", and 40 hooks on 60". Wire shelf at its base with three-sided channel frames at mid-height and top. 5" polyurethane swivel casters, two with brakes.

Flexible design allows the combination of hanger bars and wire shelves. 24" x 60" x 69" utilize 24" or 36" side wire shelves with hanger bars. Six 4" ledges on top and bottom shelf, two tote slides and boxes optional, 5" polyurethane swivel casters, two with brake. Dolly base available with 5" poly casters, two with brakes.



#CPC48B  
bulk storage cart



#CPC6024D  
combination-style cart

### EAGLE GROUP

100 Industrial Boulevard  
Clayton, DE 19938-8903 USA

Phone: 302-653-3000 • 800-441-8440

Fax: 302-653-2065

www.eaglegrp.com • www.eaglemh.com

For custom configuration or fabrication needs, contact our SpecFAB® Division.

Phone: 302-653-3000 • Fax: 302-653-2065 • e-mail: quotes@eaglegrp.com

Item No.:	_____
Project No.:	_____
S.I.S. No.:	_____

## Catheter Procedure Carts

### MODELS:

CPC6036

CPC6024D

A204176

CPC6036D

CPC48B

CPC6024

CPC60B

### Design and Construction Features—all carts

- Patented QuadTruss® design (patent #5,390,803) makes shelves up to 25% stronger and provides a retaining ledge for increased storage stability and product retention.
- Combination of hooks, shelves, and tote boxes give the versatility to hold all sizes and styles of catheter packages.
- Adjustable components. Shelves are vertically adjustable on one-inch increments, while the hook and bar assemblies can be adjusted to accommodate peel pouches 3" (76mm) or greater in width. Bars are readily removable.
- Hooks, shelf dividers, and tote boxes allow for easy organization. Label holders are provided to help in the organization of inventory. Deluxe models come standard with hooks, shelves and tote boxes, and all accessories can be adapted to create the custom system you require.
- 5" (127mm)-diameter swivel casters with polyurethane tread—two with brakes.

### Combination-Style Carts

- Three intermediate shelves, plus top and bottom shelves.
- Available in standard and deluxe styles.
- 24" width x 60" length x 69" height (610 x 1425 x 1753mm).

### Bulk Storage Carts

- Four bars, plus top and bottom shelves.
- Can be accessorized with bins, slides, tote boxes, and wire ledges.
- 24" (610mm) width, and 48" or 60" (1219 or 1524mm) length.



Item No.: \_\_\_\_\_  
 Project No.: \_\_\_\_\_  
 S.I.S. No.: \_\_\_\_\_

## Catheter Procedure Carts

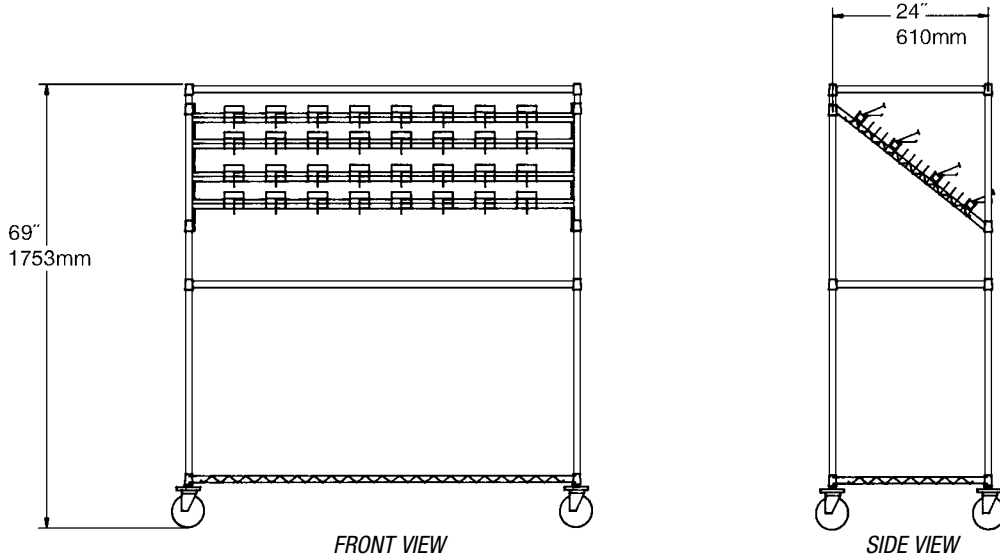

(model #CPC48C shown without ledges and bins)

### Combination-Style Carts – with 36" (914mm) side shelves and four 24" (610mm) bars

model #	width		length		weight		# of hooks included	maximum	maximum	tote slides	super bins	ledges
	in.	mm	in.	mm	lbs.	kg		# of hooks per bar	# of boxes			
CPC6036	24"	610	60"	1524	146	66.2	16	5	n/a	n/a	n/a	n/a
CPC6036D	24"	610	60"	1524	174	78.9	16	5	2	1	6	6

### Combination-Style Carts – with 24" (610mm) side shelves and four 36" (914mm) bars

model #	width		length		weight		# of hooks included	maximum	maximum	tote slides	super bins	ledges
	in.	mm	in.	mm	lbs.	kg		# of hooks per bar	# of boxes			
CPC6024	24"	610	60"	1524	149	67.6	24	9	n/a	n/a	n/a	n/a
CPC6024D	24"	610	60"	1524	162	73.5	24	9	2	1	6	6

### Bulk Storage Carts – with four 48" (1219mm) bars

model #	width		length		weight		# of hooks included	maximum	maximum	tote slides	super bins	ledges
	in.	mm	in.	mm	lbs.	kg		# of hooks per bar	# of boxes			
CPC48B	24"	610	48"	1219	82	37.2	32	13	n/a	n/a	6	6

### Bulk Storage Carts – with four 60" (1524mm) bars

model #	width		length		weight		# of hooks included	maximum	maximum	tote slides	super bins	ledges
	in.	mm	in.	mm	lbs.	kg		# of hooks per bar	# of boxes			
CPC60B	24"	610	60"	1524	101	45.8	40	17	n/a	n/a	6	6

### Replacement Catheter Hook

11 3/4" (299mm) length. Black epoxy finish.  
 model # **A204176**

#### EAGLE GROUP

100 Industrial Boulevard, Clayton, DE 19938-8903 USA  
 Phone: 302-653-3000 or 800-441-8440 • Fax: 302-653-2065  
 www.eaglegrp.com • www.eaglehmc.com

Printed in U.S.A.  
 ©2022 by Eagle Group

Rev. 05/22

Spec sheets available for viewing, printing or downloading from our online literature library at [www.eaglegrp.com](http://www.eaglegrp.com)

Although every attempt has been made to ensure the accuracy of the information provided, we cannot be held responsible for typographical or printing errors. Information and specifications are subject to change without notice. Please confirm at time of order.