



Profit from the Eagle Advantage®

Specification Sheet

Short Form Specifications

Dispenses any product on tube stock greater than 1" I.D. Consists of four posts grooved on 1" centers for adjustability, two 14" x 48" wire shelves, eight tube dispensers, one 3-sided channel frame, and two 30"-deep outrigger bases for stability. Stainless or chrome-plated finish.



roll bag dispenser

Item No.:	_____
Project No.:	_____
S.I.S. No.:	_____

Roll Bag Dispensers

MODELS:

- BD1448C**
- BD1448S**

Design and Construction Features

- Two 14" x 48" (356 x 1219mm) wire shelves.
- Eight removable dispenser bars with 40" (1016mm) length (between collar brackets) to accommodate contents, adjustable on 1" (25mm) increments.
- Four 74" (1880mm) posts with 30" (762mm) outrigger feet —featuring triangular foot plates—for stability.
- One 3-sided channel frame.
- Available in stainless steel or chrome finish.
- Custom sizes and configurations available.

Applications

- An effective means of dispensing products on rolls or spools.
- An easy way to establish protocol by color of cleanroom waste, avoiding inadvertent mixing of non-compatible items.
- Allows significant inventory to be stored at the point of use.

EAGLE GROUP

100 Industrial Boulevard
Clayton, DE 19938-8903 USA

Phone: 302-653-3000 • 800-441-8440

Fax: 302-653-2065

www.eaglegrp.com • www.eaglemhc.com

For custom configuration or fabrication needs, contact our SpecFAB® Division.

Phone: 302-653-3000 • Fax: 302-653-2065 • e-mail: quotes@eaglegrp.com

EG04.00 Rev. 05/21

Spec sheets available for viewing, printing or downloading from our online literature library at www.eaglegrp.com

Eagle Foodservice Equipment, Eagle MHC, SpecFAB®, and Retail Display are divisions of Eagle Group. ©2021 by the Eagle Group



Item No.: _____
 Project No.: _____
 S.I.S. No.: _____

Roll Bag Dispensers

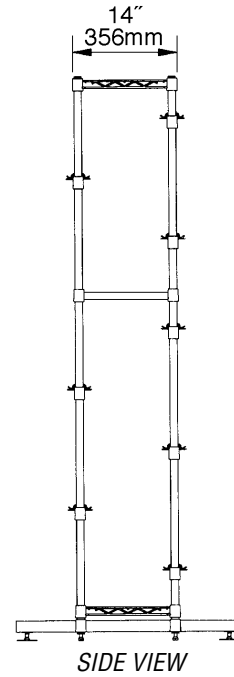
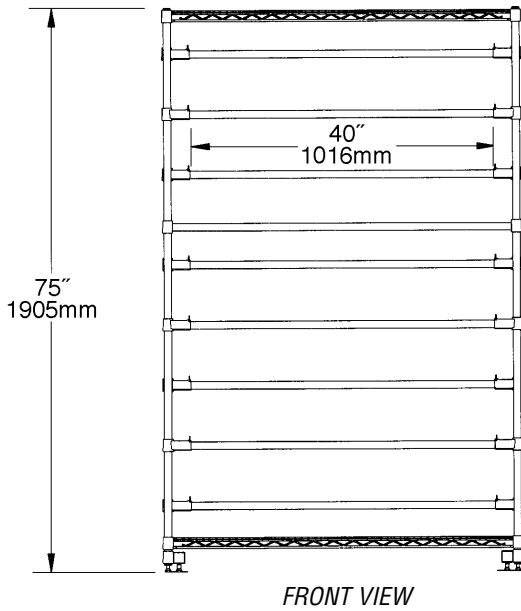
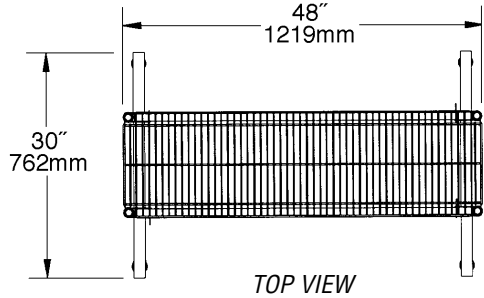

CHROME model #	STAINLESS model #	shelf width		shelf length		overall width		overall length		weight	
		in.	mm	in.	mm	in.	mm	in.	mm	lbs.	kg
BD1448C	BD1448S	14"	356	48"	1219	30"	762	48"	1219	79	35.8

Call factory for information about additional sizes.

EAGLE GROUP
 100 Industrial Boulevard, Clayton, DE 19938-8903 USA
 Phone: 302-653-3000 or 800-441-8440 • Fax: 302-653-2065
 www.eaglegrp.com • www.eaglegrp.com

Printed in U.S.A.
 ©2021 by Eagle Group
 Rev. 05/21

Spec sheets available for viewing, printing or downloading from our online literature library at www.eaglegrp.com

Although every attempt has been made to ensure the accuracy of the information provided, we cannot be held responsible for typographical or printing errors. Information and specifications are subject to change without notice. Please confirm at time of order.