



Profit from the Eagle Advantage®

Specification Sheet

Short Form Specifications

All stainless steel type 304 enclosed cabinet. 18" or 24"-deep. Flat top units are 84"-high, sloped top units are 89"-high. Widths range from 24" to 48". Five adjustable shelves. Designed and tested to the SEFA 8 Metal Casework recommended practices.

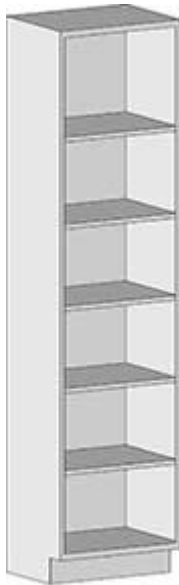

with flat top

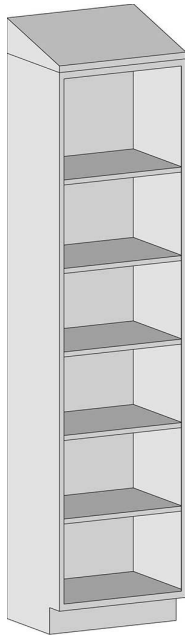

with sloped top

Item No.:	_____
Project No.:	_____
S.I.S. No.:	_____

Tall Cabinets— Open Tall Cases

MODELS:

- | | |
|---------------------------------------|---|
| <input type="checkbox"/> SSC-TOB-1824 | <input type="checkbox"/> SSC-TOBST-1824 |
| <input type="checkbox"/> SSC-TOB-1830 | <input type="checkbox"/> SSC-TOBST-1830 |
| <input type="checkbox"/> SSC-TOB-1836 | <input type="checkbox"/> SSC-TOBST-1836 |
| <input type="checkbox"/> SSC-TOB-1848 | <input type="checkbox"/> SSC-TOBST-1848 |
| <input type="checkbox"/> SSC-TOB-2424 | <input type="checkbox"/> SSC-TOBST-2424 |
| <input type="checkbox"/> SSC-TOB-2430 | <input type="checkbox"/> SSC-TOBST-2430 |
| <input type="checkbox"/> SSC-TOB-2436 | <input type="checkbox"/> SSC-TOBST-2436 |
| <input type="checkbox"/> SSC-TOB-2448 | <input type="checkbox"/> SSC-TOBST-2448 |

Design and Construction Features

- Type 304 stainless steel construction.
- Five intermediate shelves, adjustable on 3" (76mm) increments.
- Available with 18" or 24" (457 or 610mm) depth.
- Widths range from 18" to 48" (457 to 1219mm).
- Units with flat top are 84" (2134mm) high.
- Units with sloped top are 89" (2261mm) high.

Options / Accessories

- Additional shelves
- Custom sizes

CAUTION: Tall cabinets present a tipping hazard if not properly installed. Proper installation requires these cabinets to be anchored to a wall or other cabinets to improve stability and ensure door operation.

EAGLE GROUP

100 Industrial Boulevard
Clayton, DE 19938-8903 USA

Phone: 302-653-3000 • 800-441-8440

Fax: 302-653-2065

www.eaglegrp.com • www.eaglemhc.com

For custom configuration or fabrication needs, contact our SpecFAB® Division.

Phone: 302-653-3000 • Fax: 302-653-2065 • e-mail: quotes@eaglegrp.com

Certifications / Approvals



SEFA 8 Metal Casework

EG03.40 Rev. 11/21

Spec sheets available for viewing, printing or downloading from our online literature library at www.eaglegrp.com

Eagle Foodservice Equipment, Eagle MHC, and SpecFAB® are divisions of Eagle Group. ©2021 by the Eagle Group

Item No.: _____
Project No.: _____
S.I.S. No.: _____

Tall Cabinets—Open Tall Cases

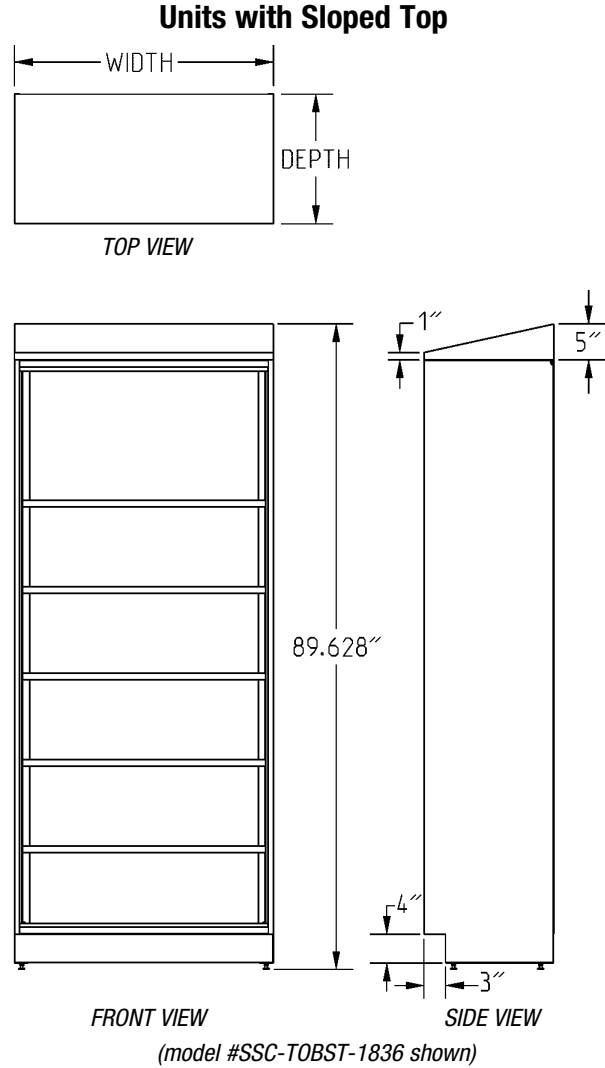
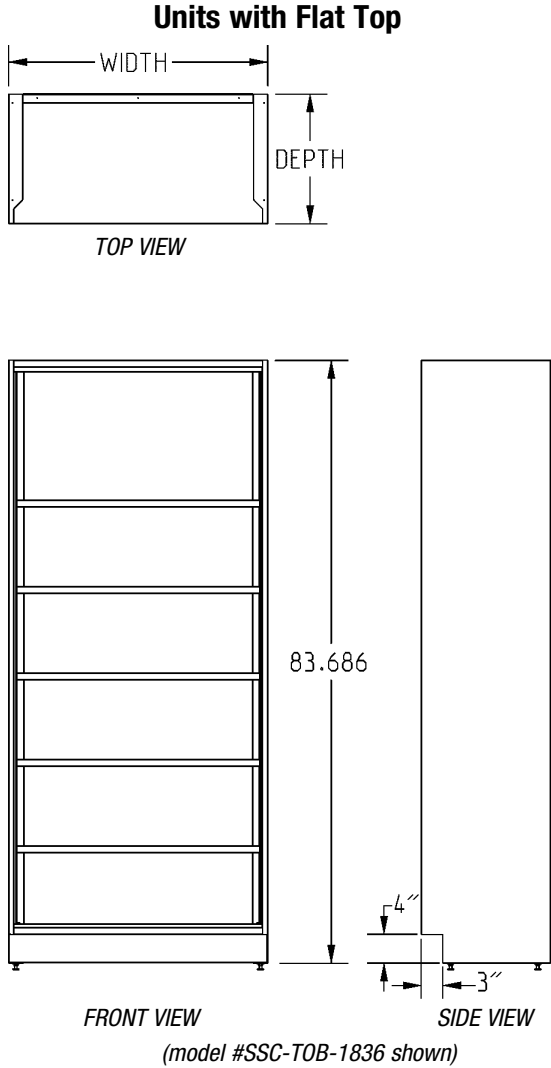

depth		width		height		weight		model #	with Sloped Top			
in	mm	in	mm	in	mm	lbs.	kg		height in.	weight lbs.	model #	
18"	457	24"	610	84"	2134	263	119.3	SSC-TOB-1824	89"	2261	283 128.3	SSC-TOBST-1824
18"	457	30"	762	84"	2134	293	132.9	SSC-TOB-1830	89"	2261	313 142.0	SSC-TOBST-1830
18"	457	36"	914	84"	2134	301	136.5	SSC-TOB-1836	89"	2261	321 145.6	SSC-TOBST-1836
18"	457	48"	1218	84"	2134	331	150.1	SSC-TOB-1848	89"	2261	351 159.2	SSC-TOBST-1848
24"	610	24"	610	84"	2134	338	153.3	SSC-TOB-2424	89"	2261	358 162.4	SSC-TOBST-2424
24"	610	30"	762	84"	2134	368	166.9	SSC-TOB-2430	89"	2261	388 176.0	SSC-TOBST-2430
24"	610	36"	914	84"	2134	413	187.3	SSC-TOB-2436	89"	2261	433 196.4	SSC-TOBST-2436
24"	610	48"	1219	84"	2134	443	200.9	SSC-TOB-2448	89"	2261	463 210.0	SSC-TOBST-2448

EAGLE GROUP
100 Industrial Boulevard, Clayton, DE 19938-8903 USA
Phone: 302-653-3000 or 800-441-8440 • Fax: 302-653-2065
www.eaglegrp.com • www.eaglemhc.com

Printed in U.S.A.
©2021 by Eagle Group
Rev. 11/21

Spec sheets available for viewing, printing or downloading from our online literature library at www.eaglegrp.com

Although every attempt has been made to ensure the accuracy of the information provided, we cannot be held responsible for typographical or printing errors. Information and specifications are subject to change without notice. Please confirm at time of order.