



Profit from the Eagle Advantage®

# Specification Sheet

## Short Form Specifications

All stainless steel type 304 enclosed cabinet. 22"-deep. 29 1/2" height. Cabinet widths offered in 18" or 24". Available with two 3"-high drawers, or with one 6"-high drawer. All cabinets feature left-swing or right-swing door. Inset construction with double-panel doors and drawer faces, door mounted with five-knuckle hinges and roller catch, drawers provided with full-extension ball bearing drawer slides, 4" wire pull on all doors and drawers, leveling feet, 4" toe kick, and adjustable shelf. Designed and tested to the SEFA 8 Metal Casework recommended practices.



#SSC-SDDL3-24



#SSC-SDDRT3-24

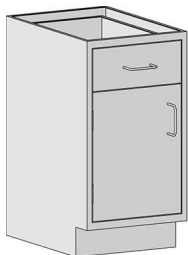

#SSC-SDDL6-18

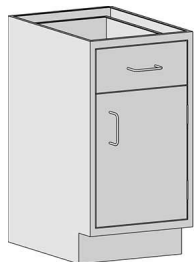

#SSC-SDDRT6-18

## EAGLE GROUP

100 Industrial Boulevard  
Clayton, DE 19938-8903 USA

Phone: 302-653-3000 • 800-441-8440

Fax: 302-653-2065

www.eaglegrp.com • www.eaglemh.com

For custom configuration or fabrication needs, contact our SpecFAB® Division.

Phone: 302-653-3000 • Fax: 302-653-2065 • e-mail: quotes@eaglegrp.com

Item No.: \_\_\_\_\_  
Project No.: \_\_\_\_\_  
S.I.S. No.: \_\_\_\_\_

## Sitting Height Base Cabinets with Door/Drawer Combination

### MODELS:

- SSC-SDDL3-18
- SSC-SDDL3-24
- SSC-SDDRT3-18
- SSC-SDDRT3-24
- SSC-SDDL6-18
- SSC-SDDL6-24
- SSC-SDDRT6-18
- SSC-SDDRT6-24

### Design and Construction Features

- Type 304 stainless steel construction.
- All units are 22" (559mm) front-to-back and 29 1/2" (740mm) height.
- Units with 3" (76mm)-high drawers feature two full drawers, and left- or right-swing door.
- Units with 6" (152mm)-high drawers feature one full drawer, and left- or right-swing door.
- Drawers and doors feature wire pull handles.
- 4" (102mm)-high toe kick.
- Inset construction with double-panel doors and drawer faces.
- Full-extension ball bearing slides.
- Five-knuckle hinges.
- Leveling feet accessible from inside the cabinet.
- Shelves adjustable on 1/2" increments.

### Options / Accessories

- Glass doors
- Door locks
- Drawer locks
- Additional shelves
- Soft-close drawer slides
- Custom drawer/door pulls
- Custom sizes

### Certifications / Approvals



SEFA 8 Metal Casework

Item No.:	_____
Project No.:	_____
S.I.S. No.:	_____

Catalog Specification Sheet No.

Sitting Height Base Cabinets with Door-Drawer Combination

## Sitting Height Base Cabinets with Door-Drawer Combination

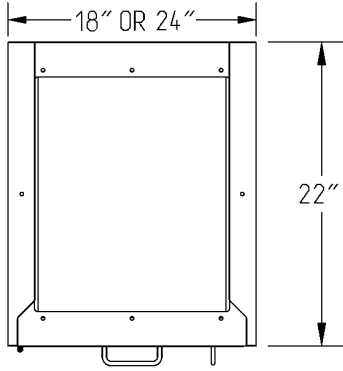

TOP VIEW OF ALL CABINETS

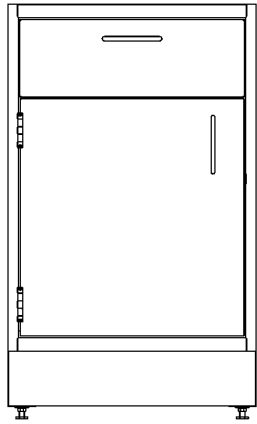

#SDDL3

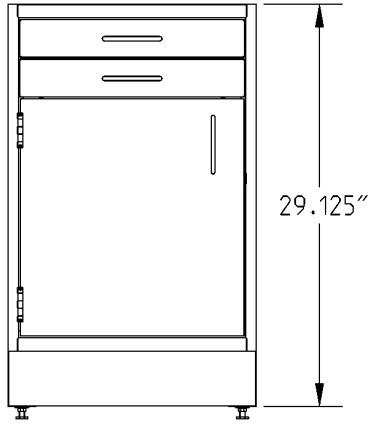

#SDDL6

FRONT VIEWS (OF UNITS WITH LEFT-SWING DOOR)

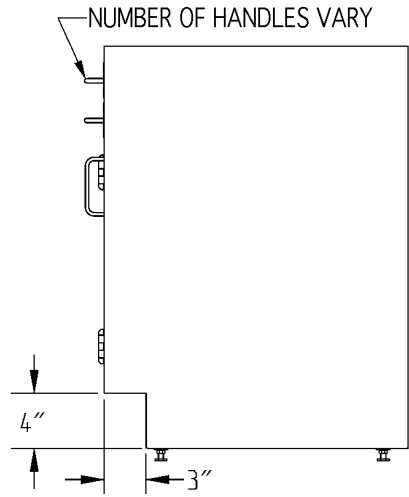

SIDE VIEW OF ALL UNITS

depth		width		door included	weight		model #	weight		model #
in	mm	in	mm		lbs.	kg		lbs.	kg	
22"	559	18"	457	left-swing door	117	53.1	<b>SSC-SDDL3-18</b>	112	50.8	<b>SSC-SDDL6-18</b>
22"	559	18"	457	right-swing door	117	53.1	<b>SSC-SDDRT3-18</b>	112	50.8	<b>SSC-SDDRT6-18</b>
22"	559	24"	610	left-swing door	142	64.4	<b>SSC-SDDL3-24</b>	137	62.1	<b>SSC-SDDL6-24</b>
22"	559	24"	610	right-swing door	142	64.4	<b>SSC-SDDRT3-24</b>	137	62.1	<b>SSC-SDDRT6-24</b>

**EAGLE GROUP**  
100 Industrial Boulevard, Clayton, DE 19938-8903 USA  
Phone: 302-653-3000 or 800-441-8440 • Fax: 302-653-2065  
www.eaglegrp.com • www.eaglegrp.com

Printed in U.S.A.  
©2021 by Eagle Group  
Rev. 11/21

Spec sheets available for viewing, printing or downloading from our online literature library at [www.eaglegrp.com](http://www.eaglegrp.com)

Although every attempt has been made to ensure the accuracy of the information provided, we cannot be held responsible for typographical or printing errors. Information and specifications are subject to change without notice. Please confirm at time of order.