



Profit from the Eagle Advantage®

Specification Sheet

Short Form Specifications

All stainless steel type 304 enclosed cabinet. 22"-deep. 29 1/2" height. Widths offered in 18" and 24". Cabinets available with two 12"-high drawers or four 6"-high drawers. Inset construction, double-panel drawer face, full-extension ball bearing drawer slides, leveling feet, 4" toe kick, removable back panel. Designed and tested to the SEFA 8 Metal Casework recommended practices.

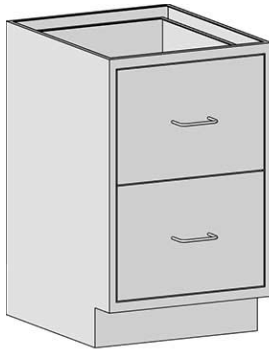

#SSC-SDB12-18

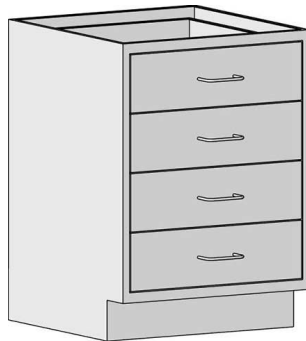

#SSC-SDB6-24

Item No.:	_____
Project No.:	_____
S.I.S. No.:	_____

Sitting Height Base Cabinets with Drawers

MODELS:

- SSC-SDB12-18
- SSC-SDB12-24
- SSC-SDB6-18
- SSC-SDB6-24

Design and Construction Features

- Type 304 stainless steel construction.
- All units are 22" (559mm) front-to-back and 29 1/2" (740mm) height.
- Available with two 12" (305mm)-high drawers or with four 6" (152mm)-high drawers.
- Full drawers with wire pull handles.
- 4" (102mm)-high toe kick.
- Inset construction with double-panel drawer face.
- Full-extension ball bearing slides.
- Leveling feet accessible from inside the cabinet.
- Removable back panel.

Options / Accessories

- Drawer locks
- Soft-close drawer slides
- Custom drawer pulls
- Custom sizes

Certifications / Approvals



SEFA 8 Metal Casework

EAGLE GROUP

100 Industrial Boulevard
Clayton, DE 19938-8903 USA

Phone: 302-653-3000 • 800-441-8440

Fax: 302-653-2065

www.eaglegrp.com • www.eaglemh.com

For custom configuration or fabrication needs, contact our SpecFAB® Division.

Phone: 302-653-3000 • Fax: 302-653-2065 • e-mail: quotes@eaglegrp.com

EG03.11 Rev. 11/21

Spec sheets available for viewing, printing or downloading from our online literature library at www.eaglegrp.com

Eagle Foodservice Equipment, Eagle MHC, and SpecFAB® are divisions of Eagle Group. ©2021 by the Eagle Group

Item No.: _____
 Project No.: _____
 S.I.S. No.: _____

Sitting Height Base Cabinets with Drawers

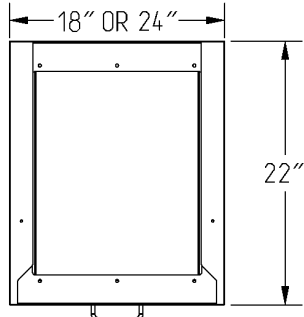

TOP VIEW OF ALL CABINETS

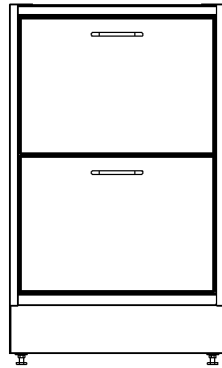

#SDB12

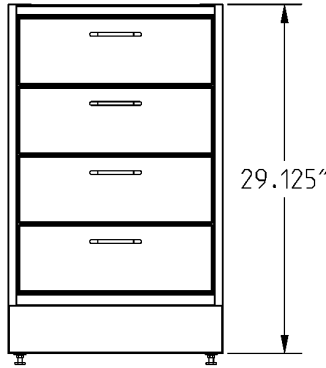

#SDB6

FRONT VIEWS

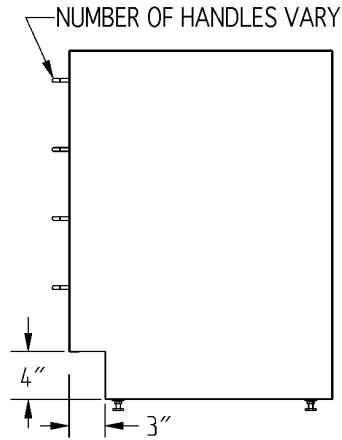

SIDE VIEW OF ALL UNITS

depth		width		with Two 12" (305mm) Drawers			with Four 6" (152mm) Drawers		
in	mm	in	mm	lbs.	kg	model #	lbs.	kg	model #
22"	559	18"	457	134	60.8	SSC-SDB12-18	142	64.4	SSC-SDB6-18
22"	559	24"	610	159	72.1	SSC-SDB12-24	167	75.7	SSC-SDB6-24

EAGLE GROUP
 100 Industrial Boulevard, Clayton, DE 19938-8903 USA
 Phone: 302-653-3000 or 800-441-8440 • Fax: 302-653-2065
 www.eaglegrp.com • www.eaglehmc.com

Printed in U.S.A.
 ©2021 by Eagle Group
 Rev. 11/21

Spec sheets available for viewing, printing or downloading from our online literature library at www.eaglegrp.com

Although every attempt has been made to ensure the accuracy of the information provided, we cannot be held responsible for typographical or printing errors. Information and specifications are subject to change without notice. Please confirm at time of order.