



Profit from the Eagle Advantage®

Specification Sheet

Short Form Specifications

All stainless steel type 304 enclosed cabinet. 22"-deep. 35" height. Widths range from 18" to 48" Available with open front, with single left- or right-swing door, or with double doors. 4" toe kick, leveling feet, removable back panel, and adjustable shelf. Doors, when provided, are inset double-panel construction, mounted with five-knuckle hinges and provided with 4" wire pull handle and roller catch. Designed and tested to the SEFA 8 Metal Casework recommended practices.

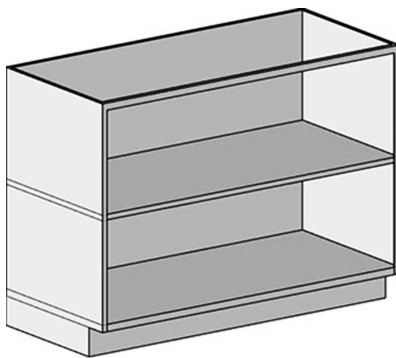

#SSC-HOB-48 cabinet with open front

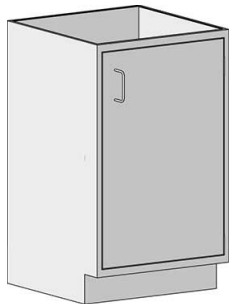

#SSC-HCBR-24 cabinet with right-swing door

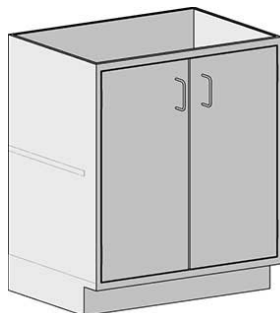

#SSC-HCB-30 cabinet with double doors

EAGLE GROUP

100 Industrial Boulevard
Clayton, DE 19938-8903 USA

Phone: 302-653-3000 • 800-441-8440

Fax: 302-653-2065

www.eaglegrp.com • www.eaglemh.com

For custom configuration or fabrication needs, contact our SpecFAB® Division.

Phone: 302-653-3000 • Fax: 302-653-2065 • e-mail: quotes@eaglegrp.com

Item No.:	_____
Project No.:	_____
S.I.S. No.:	_____

Standing Height Base Cabinets with Open Base or Full Door(s)

MODELS:

- | | |
|--------------------------------------|--------------------------------------|
| <input type="checkbox"/> SSC-HOB-18 | <input type="checkbox"/> SSC-HCBR-18 |
| <input type="checkbox"/> SSC-HOB-24 | <input type="checkbox"/> SSC-HCBL-24 |
| <input type="checkbox"/> SSC-HOB-30 | <input type="checkbox"/> SSC-HCBR-24 |
| <input type="checkbox"/> SSC-HOB-36 | <input type="checkbox"/> SSC-HCB-30 |
| <input type="checkbox"/> SSC-HOB-48 | <input type="checkbox"/> SSC-HCB-36 |
| <input type="checkbox"/> SSC-HCBL-18 | <input type="checkbox"/> SSC-HCB-48 |

Design and Construction Features

- Type 304 stainless steel construction.
- One intermediate shelf, adjustable on 1/2" increments.
- All units are 22" (559mm) front-to-back and 35" (889mm) height.
- Available with open front or with full-height hinged doors.
- Units with doors offered with single left- or right-swing door, or with double doors.
- Doors are double-panel inset construction with five-knuckle hinges, 4" wire pull, and roller catch.
- Provided with leveling feet accessible from inside the cabinet.

Options / Accessories

- Glass doors
- Door locks
- Additional shelves
- Custom door pulls
- Custom sizes

Certifications / Approvals



SEFA 8 Metal Casework

Item No.: _____
Project No.: _____
S.I.S. No.: _____

Standing Height Base Cabinets with Open Base or Full Height Door(s)

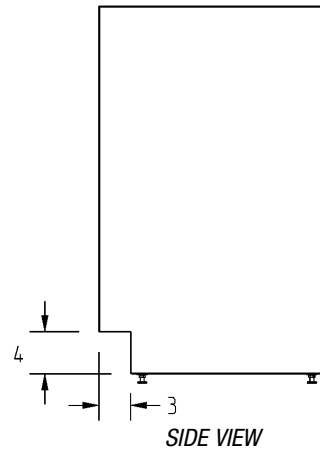
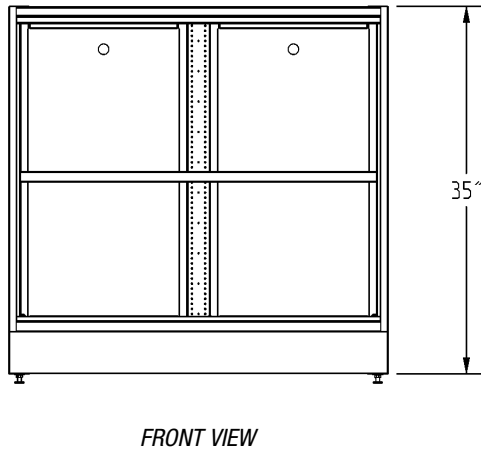
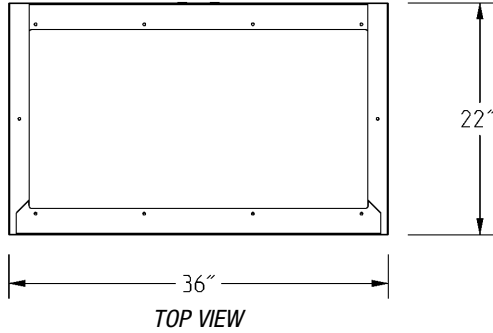

(model #SSC-HOB-36 shown)

with Open Base

depth		width		weight		model #
in	mm	in	mm	lbs.	kg	
22"	559	18"	457	74	33.6	SSC-HOB-18
22"	559	24"	610	99	44.9	SSC-HOB-24
22"	559	30"	762	124	56.2	SSC-HOB-30
22"	559	36"	914	133	60.3	SSC-HOB-36
22"	559	48"	1218	149	67.6	SSC-HOB-48

with Full-Height Door(s)

depth		width		weight		description of door(s)	model #
in	mm	in	mm	lbs.	kg		
22"	559	18"	457	99	44.9	left-swing door	SSC-HCBL-18
22"	559	18"	457	99	44.9	right-swing door	SSC-HCBL-18
22"	559	24"	610	124	56.2	left-swing door	SSC-HCBL-24
22"	559	24"	610	124	56.2	right-swing door	SSC-HCBL-24
22"	559	30"	762	174	78.9	double doors	SSC-HCB-30
22"	559	36"	914	183	83.0	double doors	SSC-HCB-36
22"	559	48"	1219	199	90.3	double doors	SSC-HCB-48

EAGLE GROUP
100 Industrial Boulevard, Clayton, DE 19938-8903 USA
Phone: 302-653-3000 or 800-441-8440 • Fax: 302-653-2065
www.eaglegrp.com • www.eaglehmc.com

Printed in U.S.A.
©2021 by Eagle Group
Rev. 11/21

Spec sheets available for viewing, printing or downloading from our online literature library at www.eaglegrp.com

Although every attempt has been made to ensure the accuracy of the information provided, we cannot be held responsible for typographical or printing errors. Information and specifications are subject to change without notice. Please confirm at time of order.