



Profit from the Eagle Advantage®

Product Announcement

Foodservice Equipment • Material Handling, Healthcare & Cleanroom Equipment • Retail Display

Short Form Specifications

Eagle Quad-Adjust® Starter Unit, model _____. EAGLEbrite® zinc, chrome, Valu-Master® Grey Epoxy, Valu-Gard® Green Epoxy, EAGLEgard® Green Epoxy with MICROGARD®, or stainless steel finish. Quad-Adjust® shelves designed for addition or removal of an intermediate shelf without disassembling entire unit. Shelf corners interlock with post-mounted collars. Top and bottom shelves are standard design and fixed in place. Patented QuadTruss® design (patent #5,390,803) on all wire shelves.

New Quad-Adjust® Starter Units



patented QuadTruss® design



Install an additional shelf without disassembling the entire shelf unit. Unit shown with EAGLEgard® finish.

Item #: _____
 Model #: _____
 Project #: _____
 SIS #: _____

Optional Accessories	Model #	Qty.
Ledges		
Dividers		
Aluminum split sleeves		
Shelf markers		

- Consists of two Quad-Adjust® shelves, two standard wire shelves, and four posts.
- Quad-Adjust® shelves feature special interlocking corners that fit in slots of collars mounted to split sleeves, allowing addition or removal of shelf without the need to disassemble the entire unit. Used for intermediate shelving only.
- Top and bottom shelves are standard wire shelves, fixed in place.
- All shelves feature patented Quad-Truss® shelves (patent #5,390,803) for increased strength and durability.
- Posts are 74" (1880mm)-high 1" (25mm)-diameter, numerically grooved. Includes post cap and leveling feet.
- Tapered plastic split sleeves.
- Convenient, easy-to-order.
- Finishes available: EAGLEbrite® zinc, chrome, Valu-Master® grey epoxy, Valu-Gard® green epoxy, EAGLEgard® green epoxy with MICROGARD®, or stainless steel. Custom colors available.

**ADD
SUBTRACT
ADJUST
IT'S THAT
EASY**

Installation of intermediate Quad-Adjust® shelves is a simple 3-step exercise:

<p>1.</p>	<p>2.</p>	<p>3.</p>
<p>1) Snap the split sleeves onto a post over the number of your choice.</p>	<p>2) Attach the Quad-Adjust® slotted collar onto the split sleeves.</p>	<p>3) Slide shelf into slotted collar to complete.</p>

Spec sheets available for viewing, printing or downloading from our online literature library at www.eaglegrp.com



Foodservice Division: (800) 441-8440
 MHC/Retail Display Divisions: (800) 637-5100
 FAX: (302) 653-2065

For custom configuration or fabrication needs, contact our **SpecFAB® Division**.
 Phone: (302) 653-3000. FAX: (302) 653-3091.
 E-mail: specfab@eaglegrp.com

100 Industrial Boulevard • Clayton, DE 19938-8903 USA • (302) 653-3000 • www.eaglegrp.com

Eagle Foodservice Equipment, Eagle MHC, SpecFAB®, and Retail Display are divisions of Eagle Group. ©2011 by the Eagle Group

EG8115 Rev. 07/11

Quad-Adjust® Starter Units

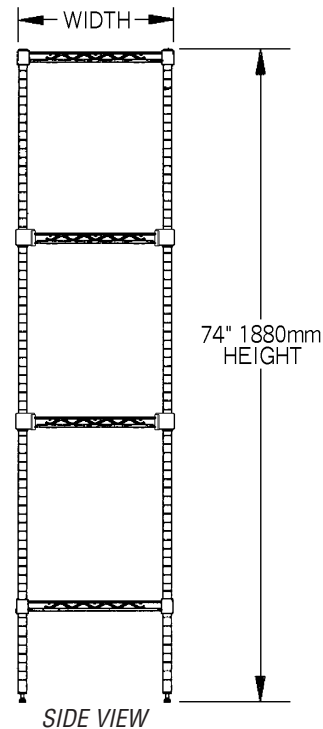
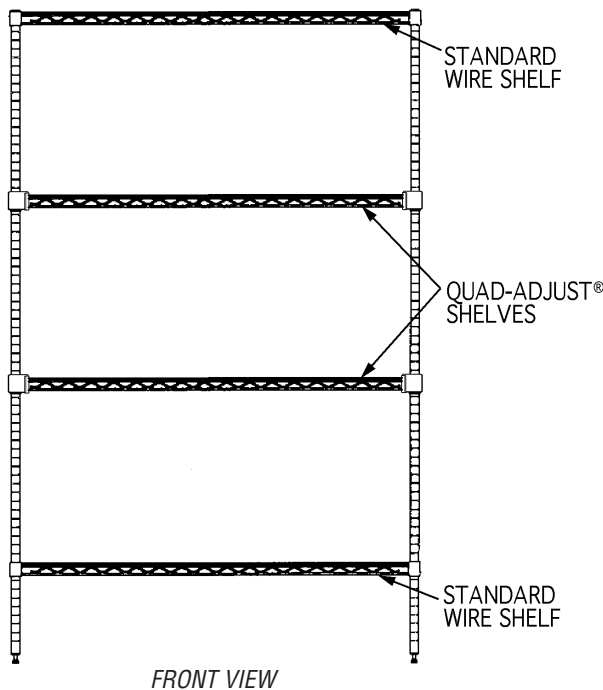
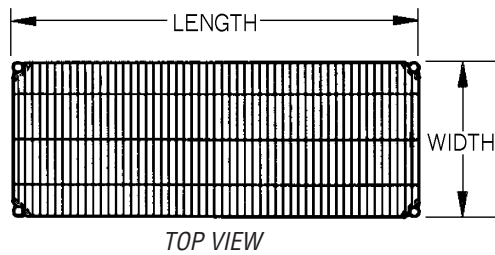

18" (457mm)-Wide Units

length in. mm	weight lb. kg	EAGLEbrite® model #	chrome model #	Valu-Master® model #	Valu-Gard® model #	EAGLEgard® * model #	stainless steel model #
36" 914	65 29.5	F2QA2-74-1836Z	F2QA2-74-1836C	F2QA2-74-1836V	F2QA2-74-1836VG	F2QA2-74-1836E	F2QA2-74-1836S
48" 1219	78 35.4	F2QA2-74-1848Z	F2QA2-74-1848C	F2QA2-74-1848V	F2QA2-74-1848VG	F2QA2-74-1848E	F2QA2-74-1848S
60" 1524	102 46.3	F2QA2-74-1860Z	F2QA2-74-1860C	F2QA2-74-1860V	F2QA2-74-1860VG	F2QA2-74-1860E	F2QA2-74-1860S
72" 1819	117 53.1	F2QA2-74-1872Z	F2QA2-74-1872C	F2QA2-74-1872V	F2QA2-74-1872VG	F2QA2-74-1872E	F2QA2-74-1872S

* MICROGARD® antimicrobial protection standard on all EAGLEgard® shelving.

24" (610mm)-Wide Units

length in. mm	weight lb. kg	EAGLEbrite® model #	chrome model #	Valu-Master® model #	Valu-Gard® model #	EAGLEgard® * model #	stainless steel model #
36" 914	81 36.7	F2QA2-74-2436Z	F2QA2-74-2436C	F2QA2-74-2436V	F2QA2-74-2436VG	F2QA2-74-2436E	F2QA2-74-2436S
48" 1219	98 44.5	F2QA2-74-2448Z	F2QA2-74-2448C	F2QA2-74-2448V	F2QA2-74-2448VG	F2QA2-74-2448E	F2QA2-74-2448S
60" 1524	122 55.3	F2QA2-74-2460Z	F2QA2-74-2460C	F2QA2-74-2460V	F2QA2-74-2460VG	F2QA2-74-2460E	F2QA2-74-2460S
72" 1819	149 67.6	F2QA2-74-2472Z	F2QA2-74-2472C	F2QA2-74-2472V	F2QA2-74-2472VG	F2QA2-74-2472E	F2QA2-74-2472S

* MICROGARD® antimicrobial protection standard on all EAGLEgard® shelving.